

# MANAGEMENT MATRIX INTEGRATING LOGISTICS SUPPORT PLANNING EVENTS

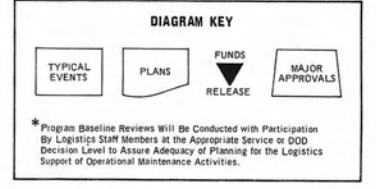
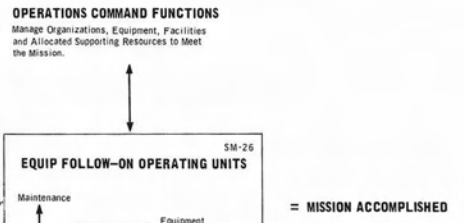
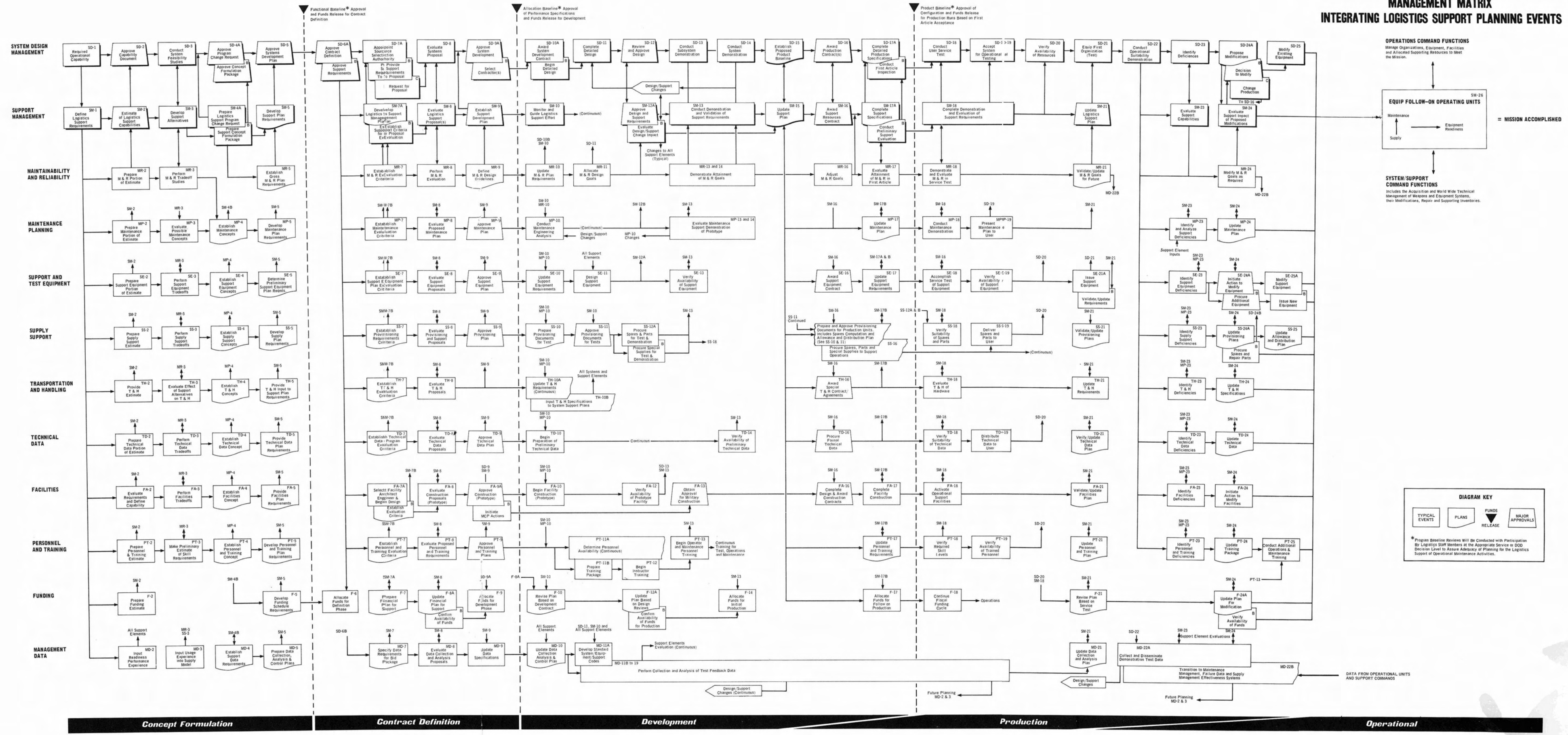

## Research Reports

Authorized DOD contractors and grantees may obtain these documents without charge from

Defense Documentation Center  
Cameron Station  
Alexandria, Va. 22314

Others may purchase these documents at a price of \$3 each (microfiche 65¢) unless otherwise indicated, from:

Clearinghouse for Federal and Scientific Information  
Department of Commerce  
Springfield, Va. 22151

**Naval Gunfire Support.** This U.S. Marine Corps manual contains information and guidance concerning the organization, command relationships, and planning considerations for naval gunfire support in amphibious operations. 1967. 171 p. il. D214.9/4:7-2/2. \$1.25.

**Abstracting Scientific and Technical Reports of Defense-Sponsored RDT&E.** Defense Documentation Center, Cameron Station, Alexandria, Va., March 1968, 18 p. Order No. AD-667 000.

**A Summary of the State of the Art in Microfilm Document Storage and Retrieval Systems.** Rome Air Development Center, Griffiss AFB, N.Y., Sept. 1967, 113 p. Order No. AD-820 127.

**Oceanographic Comment on Apollo 501 Mission Photography.** Texas A&M University, College Station, Tex., for the Navy, Nov. 1967, 92 p. Order No. AD-663 457.

**Sixth Annual Technical Report: Expanded Research Program in Materials Sciences for Period July 1, 1966 through June 30, 1967.** University of Chicago, for the Advanced Research Projects Agency, Dec. 1967, 88 p. Order No. AD-663 152.

**Oxygen-Corner-Expansion Flows with Coupled Vibrational and Dissociational Nonequilibrium.** University of Toronto, Canada, for the Air Force, Dec. 1967, 78 p. Order No. AD-663 244.

**A Study of Penetration of a Liquid Injectant into a Supersonic Flow.** Aerospace Corp., El Segundo, Calif., for the Air Force, Oct. 1967, 39 p. Order No. AD-663 417.

**Impurity Photoionization Theory of Precursors.** Polytechnic Institute of Brooklyn, for the Navy, Oct. 1967, 38 p. Order No. AD-663 145.

**Calibration of Hot-Film Sensors in a Towing Tank and Application to Quantitative Turbulence Measurements.** U.S. Naval Academy, March 1967, 55 p. Order No. AD-663 098.

**A Review of Ceramic Thin Film Technology.** General Precision Systems, Glendale, Calif., for the Air Force, Oct. 1967, 167 p. Order No. AD-660 590.

**Preparation and Characterization of High Quality Single Crystal Refractory Metal Carbides.** Westinghouse Electric Corp., Pittsburgh, Pa., for the Air Force, Oct. 1967, 77 p. Order No. AD-663 248.

## GOVERNMENT PRINTING OFFICE PUBLICATIONS

These publications may be purchased at the prices indicated from:

Superintendent of Documents  
U.S. Government Printing Office  
Washington, D.C. 20402

**U.S. Government Organization Manual 1967-68.** Presents essential information about government agencies and provides supplemental information including brief descriptions of quasi-official agencies and selected international organizations. Also lists several hundred representative publications showing the types of published materials available from Government establishments. GS 4.109:967. \$2.

**Department of Defense Security Posters (size 22 x 14 inches): Do You Take Security Regulations Seriously Enough? D 7.19:5220.2. 10¢; Security is Always in Season. D 7.19:5220.3. 15¢; Let's Face It, Security is Up to You. D.7.19:5220.4. 15¢; Don't Guess, Ask Your Security Supervisor. D 7.19:5220.5. 15¢; Security Takes No**

**Vacation. D 7.19: 5220.6. 15¢; You Can't Pass it, Security is an Individual Responsibility. D7.19:5220.7. 15¢.**

**MILSCAP, Military Standard Contract Administration Procedures.** Prescribes standard procedures for use in exchanging procurement/contract administration data between purchasing offices and field contract administration offices. Basic Manual. 1967. 211 p. D 7.6/4:M59/3. \$1.25. Change 1. 1967. 78 p. D7.6/4:M59/3/ch.1 40¢.

**DOD Annual Report for FY 1965.** Includes annual report of the Secretary of Defense for FY 1965, together with the reports of the Secretaries of the Army, Navy, and Air Force for the same period. 1967. 445 p. il. D1.1:965. \$1.75.

**Fire Support Coordination.** This U.S. Marine Corps manual provides doctrine, tactics, and techniques for the coordination of fire support during amphibious operation and subsequent operations ashore. 1967. 236 p. il. D214.9/4:7-1. \$2.50.

## Defense Procurement Circulars

Distribution of Defense Procurement Circulars is made automatically by the U. S. Government Printing Office to subscribers of the Armed Services Procurement Regulation (ASPR).

**Defense Procurement Circular No. 60, April 1, 1968.** (1) Expiration of Deviations from ASPR and DOD Publications. (2) Relationships with Defense Contractors. (3) Use of Government-Owned Industrial Plant Equipment by Contractors. (4) Use and Charges Clause 7-702.12. (5) Index of 100 Parent Companies Which with Their Subs, etc. (6) Material Inspection and Receiving Report (MIRR) (DD 250). (7) Disposition of Post Award Audits. (8) Master List of Contractors for Negotiated Overhead Rates and Advance Agreements for Independent R&D Costs. (10) Pricing of Technical Data.

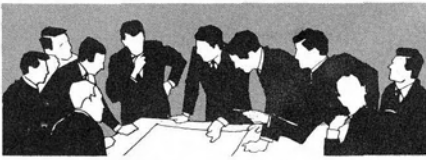

## MEETINGS AND SYMPOSIA

### JUNE

**Atomic Physics Conference**, June 12-15, at New York University. Sponsors: Army Research Office—Durham, AEC, National Science Foundation, Air Force Office of Scientific Research, Office of Naval Research, New York University, Brookhaven National Laboratory and the International Union of Pure and Applied Physics. Contact: Robert Mace, Director, Physics Div., Army Research Office-Durham, Box CM, Duke Station, Durham, N.C. 27706, Phone (919) 286-2285.

**Multivariate Analysis Symposium**, June 17-22, at Dayton, Ohio. Co-sponsors: Aerospace Research Laboratories and Wright State University. Contact: Dr. P. R. Krishnaiah (ARM), Aerospace Research Laboratories, Wright-Patterson AFB, Ohio 45433, Phone (513) 255-3761.

**Bioastronautics and the Exploration of Space Fourth International Symposium**, June 23-27, at San Antonio, Tex. Sponsor: Aerospace Medical Div., (AFSC). Contact: Dr. Mitchell (AMRS), Aerospace Medical Div., (AFSC), Brooks AFB, Tex. 78235, Phone (512) LE 2-8811, Ext. 3211.

### JULY

**High Temperature Chemistry Conference**, (dates undetermined), in Crystal Springs, Wash. Sponsor: Office of Aerospace Research. Contact: Dr. Donald L. Ball, Air Force Office of Scientific Research (SRC), 1400 Wilson Blvd., Arlington, Va. 22209, Phone (202) OX 4-5337.

**Fourth Annual Marine Technology Society Conference and Exhibit**, July 8-10, in Washington, D.C. Sponsor: Marine Technology Society. Contact: Ted Evans, Conference Management Organization, Inc., Sheraton Park Hotel, 2660 Connecticut Ave., N.W., Washington D.C. 20008.

**Crystal Growth Conference**, July 15-19, at the University of Birmingham, England. Sponsors: Air Force Cambridge Research Laboratories,

U. K. Ministry of Technology, International Committee on Crystal Growth and the International Union of Pure and Applied Physics. Contact: Charles S. Sahagian (CRWB), Air Force Cambridge Research Laboratories, L. G. Hansom Field, Mass. 01730, Phone (617) 274-6100, Ext. 3298.

**Aurora and Airglow Conference**, July 29-Aug. 9, at the Agricultural College of Norway, As, Norway. Sponsors: Office of Aerospace Research, Office of Naval Research, Defense Atomic Support Agency and the Air Force Cambridge Research Laboratories. Contact: K. W. Champion, Air Force Cambridge Research Laboratories (CRUB), L. G. Hanscom Field, Mass. 01730, Phone (617) 274-6100, Ext. 3033.

### AUGUST

**Second International Conference on Liquid Crystal**, (dates undetermined), at Kent, Ohio. Co-sponsors: Office of Scientific Research and Kent State University. Contact: Lt. Col. E. T. Walford, Office of Aerospace Research (SRC), 1400 Wilson Blvd., Arlington, Va. 22209, Phone (202) OX 4-5337.

**International Federation for Information Processing (IFIP) International Congress**, Aug. 5-10, at Edinburgh, Scotland. Sponsor: Office of Aerospace Research. Contact: Mrs. R. W. Swanson, Air Force Office of Scientific Research (SRC), 1400 Wilson Blvd., Arlington, Va. 22209, Phone (202) OX 4-5407.

**Second National Conference on Space Maintenance and Extra-Vehicular Activities**, Aug. 6-8, at Las Vegas, Nev. Sponsors: Air Force Aero Propulsion Laboratory, Ling-Temco-Vought, Inc., and the National Aeronautics and Space Administration. Contact: Mr. Clodfelter (APFT), Wright-Patterson AFB, Ohio 45433, Phone (513) 357-1110, Ext. 55875.

**Body Temperature Regulation in Man Symposium**, Aug. 19-24, at New Haven, Conn. Sponsor: Office of

Aerospace Research. Contact: Dr. H. E. Savely, Air Force Office of Scientific Research (SRL), 1400 Wilson Blvd., Arlington, Va. 22209, Phone (202) OX 4-5041.

**Twenty-Fourth International Congress of Physiological Sciences**, Aug. 25-30, in Washington, D.C. Sponsor: Office of Aerospace Research. Contact: Dr. H. E. Savely, Air Force Office of Scientific Research (SRL), 1400 Wilson Blvd., Arlington, Va. 22209, Phone (202) OX 4-5041.

### EASCON '68 in Washington D.C., Sept. 9-11

"The Changing World of Electronics" will be the theme of EASCON '68 Exposition (Electronics and Aerospace Systems Convention/Exposition) to be held Sept. 9-11, 1968, at the Sheraton Park Hotel, Washington, D.C.

The three-day conference and exposition will combine technical sessions and related displays to offer a balanced program on the latest developments in aerospace electronic systems and equipment.

Sponsored by the Institute of Electrical and Electronics Engineers, the EASCON '68 Exposition will include technical sessions covering 12 major areas in the field of electronics, including communication, aeronautical, space and underwater systems.

Attendance at the technical sessions and the exposition is encouraged from Defense Department and other government agencies as well as the electronics industry. An advanced registration fee of \$1 will be charged and a \$2 entry fee will apply to government and military personnel attending the technical sessions. No registration fee will be charged for attendance at the exposition.

For further information on EASCON '68 Exposition, the contact is: Mrs. Harriet H. Manley, Page Communications Engineers, Inc., 3300 Whitehaven St. N.W., Washington, D.C. 20007, Phone (202) 337-7600.