

**IBM**

Space Systems Center  
Huntsville, Alabama

**IU System Description  
and Component Data**

**IBM**

Saturn IB/V - Instrument Unit  
**Technical Manual**

XIII.4

MSPC No. III-S-509-4  
IBM No. 66-966 0006

**IU System Description  
and Component Data**



**MSFC No. III-5-509-4**

**IBM No. 66-966-0006**

**TECHNICAL MANUAL**

**SATURN IB/V INSTRUMENT UNIT  
SYSTEM DESCRIPTION  
AND  
COMPONENT DATA**

**(S-IU-201-212/501-515)**

**Prepared under Contract**

**NAS 8-14000**

**by**

**International Business Machines Corporation**

**Federal Systems Division**

**Huntsville, Alabama**

**1 June 1966**

**Changed 1 May 1969**

INSERT LATEST CHANGED PAGES, DESTROY SUPERSEDED PAGES

# LIST OF EFFECTIVE PAGES

NOTE: The portion of the text affected by the changes is indicated by a vertical line in the outer margins of the page.

PAGE	ISSUE	PAGE	ISSUE
*Title	1 May 68	88 Blank	Original
*A	1 May 69	87 thru 89	1 Dec 66
1 thru 11	1 Dec 66	88A Added	1 Dec 66
1 thru 3	1 Dec 66	89B	1 Jun 67
*4	1 May 69	89	1 May 69
5	1 Jul 68	90	Original
*6 thru 7	1 May 69	91	1 Dec 66
8	1 Jul 68	*92	1 May 69
*9	1 May 69	93	Original
10 thru 11	1 Jul 68	94	1 Jun 67
*12	1 May 69	95 thru 96	Original
13	1 Jul 68	96	1 Dec 67
14	1 Jun 67	*100	1 May 68
15	1 Dec 67	100A thru 100B Added	1 Dec 66
16 thru 17	1 Jun 67	101	1 Jun 67
18 thru 19	1 Dec 67	102	1 Dec 68
*20	1 May 69	102A	1 Dec 67
21	1 Dec 67	102B Deleted	1 Jul 68
*22	1 May 69	103	Original
23 thru 28	1 Jul 68	104 thru 105	1 Dec 67
30	1 Dec 67	108 thru 108	1 Dec 66
31	1 Jun 67	109	Original
32	1 Jul 68	110	1 Dec 66
33 thru 34	1 Jun 67	111	1 Dec 67
35	1 Dec 67	112	Original
36	1 Jun 67	113 thru 116	1 Dec 67
37	1 Jul 68	116	1 Dec 67
*38	1 May 69	117 thru 118	Original
39 thru 40	1 Jun 67	120 Blank	Original
41	1 Dec 67	121	Original
*42 thru 43	1 May 69	122	1 Dec 66
44	1 Jul 68	123	1 Jun 67
44A Added	1 Jun 67	124	1 Dec 68
44B	1 Jul 68	125	1 Jun 67
45	1 Jun 67	126 thru 128	1 Dec 67
*46	1 May 69	129 thru 131	Original
46A thru 46C Added	1 Dec 68	132	1 Dec 68
46D Blank Added	1 Dec 66	133 thru 134	Original
47 thru 50	1 Dec 67	135 thru 136	1 Jun 67
51	1 Jun 67	137 thru 140	Original
52	1 Dec 67	141	1 Dec 66
53	Original	142	Original
54 thru 58	1 Dec 68	143	1 Jun 67
58A	1 Dec 67	144 thru 146	Original
57	Original	147	1 Dec 67
58	1 Dec 67	148	Original
59 thru 60	Original	148	1 Dec 66
60A	1 Dec 67	150	1 Dec 67
61 thru 62	Original	151	1 Jun 67
62A	1 Dec 67	152 thru 153	Original
63 thru 64	Original	154 thru 155	1 Jun 67
*65 thru 65	1 May 69	*156 thru 157	1 May 68
67 thru 68	Original	158	1 Jun 67
68A	1 Dec 67	159 thru 160	1 Dec 66
69	Original	161	1 Jun 67
70	1 Jun 67	162	1 Dec 66
71	Original	163	1 Dec 67
72	1 Jun 67	164 thru 168	1 Dec 68
72A thru 72H Added	1 Dec 66	169 thru 175	Original
73 thru 75	Original	179 thru 180	1 Jul 68
76	1 Jun 67	181 thru 228	1 Dec 67
77 thru 78	Original	229 thru 230	1 Jul 68
79	1 Jun 67	231 thru 233 Added	1 Dec 67
80 thru 82	Original	234 Blank Added	1 Dec 67
83	1 Dec 66		
84 thru 85	Original		

\* The asterisk indicates pages changed, added, or deleted by the current change.

BASIC	REVISION	CHANGE NO. 1	CHANGE NO. 2	CHANGE NO. 3	CHANGE NO. 4	CHANGE NO. 5		
1 MAR 1968	1 JUN 1968	1 DEC 1966	1 JUN 1967	1 DEC 1967	1 JUL 1968	1 MAY 1969		

## CONTENTS

	Page
Introduction . . . . .	1
Component Alphabetical Listing . . . . .	3
Component Numerical Listing . . . . .	27
IU Interconnect Diagrams, Schematics, Segment Wire Lists, and Cable Installation Drawing Numbers . . . . .	46A
Color Coded Component Location Illustrations . . . . .	47
Antenna Locations and Photographs . . . . .	70
Structural System . . . . .	72A
Electrical System . . . . .	73
Environmental Control System . . . . .	87
Guidance and Control System . . . . .	107
Measuring and Telemetry System . . . . .	121
Radio Frequency System . . . . .	153
Component Removal and Replacement Data . . . . .	177

This manual has been prepared to assist personnel to familiarize themselves with the Instrument Unit components. Also, the manual is designed to be used as a reference for component part numbers, specification numbers, and component locations.

Requests for additional copies and comments suggesting additions, deletions, or corrections should be forwarded to the following address. Also, if you have obtained your copy through other than a formal distribution channel, send your name and address to the address below to insure receiving revisions to the manual.

Technical Manual Distribution  
Department 966  
IBM Corporation  
Federal Systems Division  
P.O. Box 1250  
Huntsville, Alabama 35805

**IU**



**SATURN IB**

**SATURN V**

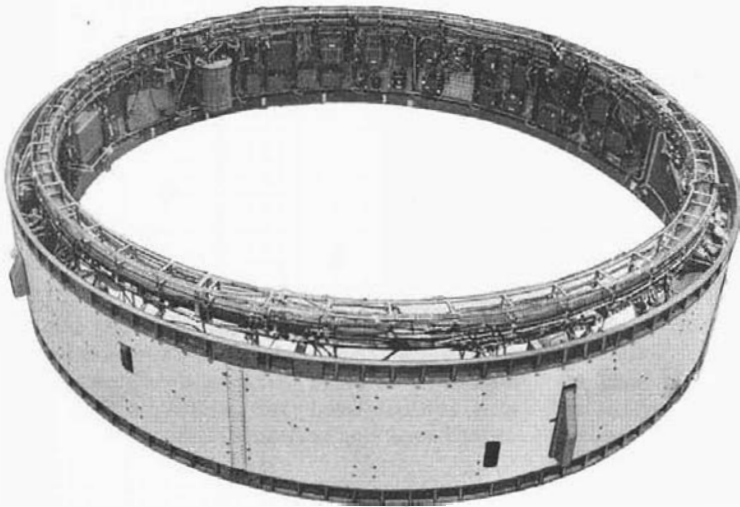

IBM N95

**Saturn Instrument Unit (With Forward and Aft Protective Rings Installed)**

## INTRODUCTION

This manual contains a brief description of each Instrument Unit (IU) system and their respective components for S-IU-201 through 212 and S-IU-501 through 515. All components within a particular system are restricted to one section of the manual and are in alphabetical order. Related reference material follows each component description, such as, specification numbers, effectivity, and location.

The IU structure consists of three 120-degree segments fabricated from aluminum honeycomb. The three segments are joined to form a cylindrical structure 260 inches in diameter and 36 inches in height, which mounts on top of the S-IVB stage. The components of the Saturn Astrionics System are mounted on mounting and thermal conditioning panels which are attached to the inner side of the cylindrical structure. This arrangement provides clearance for the landing gear of the Lunar Excursion Module sitting on top of the IU and for the bulkhead of the S-IVB tank extending into the IU.

After the IU has been assembled and mounted on top of the S-IVB stage, a door provides access to the components inside the structure. This access door has been designed to act as a load carrying part of the structure in flight. In addition, the structure contains an umbilical door which is spring-loaded and will close after retraction of the umbilical arm at lift-off. The IU structure provides a path for static and dynamic loads resulting from the payload above the IU.

Three tables have been provided; Table 1 lists component names in alphabetical order and includes component part numbers, reference designation numbers, the panel number to which the component is mounted, Figure 1 callout numbers, vehicle effectivity, and the page number on which a component description can be found.

Table 2 is a cross reference that can be used when only the component part number is known, so that the corresponding component name may be found in Table 1.

Table 3 is a listing of IU cable interconnection diagrams, IU electrical schematics, and segment wire lists or cable installation drawings with their part numbers and effectivity.

Two figures are included to assist in locating individual components. Figure 1 is a series of three-panel sections that are color coded by system, illustrating the components mounted on their respective panels. Several of the three-panel sections in Figure 1 appear more than once. The three-panel sections are repeated to illustrate the various component configurations which change from vehicle to vehicle. Those components whose configurations do not

change are shaded, but those that do change are color coded. Each component in Figure 1 is assigned a callout number. This callout number can in turn be found in the legend for Figure 1 beginning on page 47 in order to find the corresponding component name. To ascertain the part number, effectivity, etc. for a component, its name appears in alphabetical order in Table 1 with pertinent information about the component adjacent to the component name. Figure 2 depicts the outer surface of the IU showing the various antenna locations.

Component removal and replacement information is included in the manual and contains such data as, mounting hardware part numbers, tools required, etc.

This manual was written with the best information available at the time of publication, however, it should be emphasized that component configuration and quantities are continually changing.

**NOTE: FOR PURPOSES OF THIS MANUAL THE WORD ALL ENCOMPASSES VEHICLE EFFECTIVITIES 201-212/501-515.**

**TABLE 1**  
**ALPHABETICAL**



Table 1. Instrument Unit Component Alphabetical List

Nomenclature	Part Number	Reference Designation	Loc. on Panel	Fig. 1 Loc. No.	Vehicle Effectivity	Page
Accelerometer Signal Conditioner	50M22107-003	603A21	20	104	201-204 & 501	109
	50M22107-005	603A21	20	104	205-206 502	109
	50M22107-009	603A21	20	104	207-212 503-515	109
Access Door	Ref. Page 72D	--	8	42A	201-212 501-515	72D
Auxiliary Power Distributor	40M37213-001	601A33	1	4	201	75
	40M37214-001	602A34	9	51	201	
	40M37220-001	602A33	1	4	202	
	40M37221-001	602A34	9	51	202	
	40M37227-001	601A33	1	4	203	
	40M37228-001	602A34	9	51	203	
	40Z37234-001	601A33	1	4	204	
	40Z37235-001	602A34	9	51	204	
	7910420-001	601A33	1	4	205	
	7910421-001	602A34	9	51	205	
	7910420-003	601A33	1	4	206	
	7910421-003	602A34	9	51	206	
	7910420-005	601A33	1	4	207	
	7910421-005	602A34	9	51	207	
	7910420-007	601A33	1	4	208	
	7910421-007	602A34	9	51	208	
	7910420-009	601A33	1	4	209	
	7910421-009	602A34	9	51	209	
	7910420-011	601A33	1	4	210	
	7910421-011	602A34	9	51	210	
	7910420-013	601A33	1	4	211	
	7910421-013	602A34	9	51	211	
	7910420-015	601A33	1	4	212	
	7910421-015	602A34	9	51	212	
	7910420-021	601A33	1	4	501	
	7910421-021	602A34	9	51	501	
	7910420-023	601A33	1	4	502	
	7910421-023	602A34	9	51	502	
	7910420-025	601A33	1	4	503	
	7910421-025	602A34	9	51	503	
	7910420-027	601A33	1	4	504	
7910421-027	602A34	9	51	504		
7910420-029	601A33	1	4	505		

Table 1. Instrument Unit Component Alphabetical List (Continued)

Nomenclature	Part Number	Reference Designation	Loc. on Panel	Fig. 1 Loc. No.	Vehicle Effectivity	Page
Auxiliary Power Distributor	7910421-029	602A34	9	51	505	75
	7910420-031	601A33	1	4	506	
	7910421-031	602A34	9	51	506	
	7910420-033	601A33	1	4	507	
	7910421-033	602A34	9	51	507	
	7910420-035	601A33	1	4	508	
	7910421-035	602A34	9	51	508	
	7910420-037	601A33	1	4	509	
	7910421-037	602A34	9	51	509	
	7910420-039	601A33	1	4	510	
	7910421-039	602A34	9	51	510	
	7910420-041	601A33	1	4	511	
	7910421-041	602A34	9	51	511	
	7910420-043	601A33	1	4	512	
	7910421-043	602A34	9	51	512	
	7910420-045	601A33	1	4	513	
	7910421-045	602A34	9	51	513	
	7910420-047	601A33	1	4	514	
	7910421-047	602A34	9	51	514	
	7910420-049	601A33	1	4	515	
7910421-049	602A34	9	51	515		
Azusa Antenna Mod 711	50Z12333-001	601A428	See Fig. 2		201-208 501-505	--
Azusa RI Filter Assembly	50M12267-001	603A426	23	109	201-204 501-502	156
Azusa Transponder Type C	50M12266-001	603A427	23	110	201-204 501-502	157
Battery D10	40M20780-001	601A7	5	26	201-203	76
Battery D10	40Z20780-001	601A7	5	26	204-212 501-515	
Battery D20	40M20780-003	601A8	5	32	201-203	76
Battery D20	40Z20780-001	601A8	5	32	204-205 207-208 501-503	
Battery D30	40M20780-005	601A9	4	27	201-203	

Table 1. Instrument Unit Component Alphabetical List (Continued)

Nomenclature	Part Number	Reference Designation	Loc. on Panel	Fig. 1 Loc. No.	Vehicle Effectivity	Page
Battery D30	40Z20780-001	601A9	4	27	204-212 501-515	
Battery D40	40M20780-007	601A10	4	28	201-203	76
Battery D40	40Z20780-001	601A10	4	28	204-212 501-515	
Cable Tray	10Z22257-001	--	--	--	201-212 501-515	72E
Camera Control Unit (GEC)	50M12521	603A650	24	10	202	158
Camera Control Unit (GEC)	50M12521	603A613	24	19	203	
Camera Control Unit (Kintel)	50M12520	603A612	24	20	203	
C-Band Antenna Mod 708	50M10347	603A435	See Fig. 2		201-202	--
C-Band Antenna Mod 713	50M12504 50Z12504-001 50Z12504-001	603A577 603A577 602A618	See Fig. 2		203 204-212 501-515 204-212 501-515	-- -- --
C-Band Transponder	50M12261-001 50Z12261 50Z12574-001 50Z12574-003 or 50Z12574-005 50Z12574-003 or 50Z12574-005 50Z12574-005	603A434 603A434 602A619 603A653 602A634 602A635 602A635 602A634 602Z634	23 23 12 23 23 12 12 23 23	108 108 71 108 108 71 71 108 108	201-202 203 204 204 205 & 501 205 & 501 206-208 502-504 206-207 502-504 208-212 505-515	159

Table 1. Instrument Unit Component Alphabetical List (Continued)

Nomenclature	Part Number	Reference Designation	Loc. on Panel	Fig. 1 Loc. No.	Vehicle Effectivity	Page
C-Band Transponder	50Z12574-005	602A635	12	71	208-212 505-515	159
CCS Coaxial Switch Mod 612	50M13016-001	603A629	24	25	501-503	160
	50Z13016-001				504-515	
CCS Directional Antenna Mod 609	50M13018-001	601A32	See Fig. 2		501-503	--
CCS Directional Antenna Mod 609	50Z13018-001	601A32	See Fig. 2		504-515	--
CCS Hybrid Ring Mod 608	50M13015	603A631	17	93	501-504	161
CCS Power Amplifier	50M12673	603A637	24	22	501-503	162
	50Z12673-001				504-506	
	50Z12673-003				507-515	
CCS Power Divider Mod 607	50M12527	603A626	17	94	501-503	163
	50Z12527-001	603A626		94	504-515	
	50Z12527-001	603A691		90E	505-515	
CCS Receiving Antenna Mod 610	50M13019	602A627	See Fig. 2		501	--
	50M13019	603A628			501	--
	50M13019-001	602A627			502-503	--
	50M13019-001	603A628			502-503	--
	50Z13019-001	602A627			504-515	--
	50Z13019-001	603A628			504-515	--
CCS Transponder	50M13017-003	603A636	24	21	501-503 506	164

Table 1. Instrument Unit Component Alphabetical List (Continued)

Nomenclature	Part Number	Reference Designation	Loc. on Panel	Fig. 1 Loc. No.	Vehicle Effectivity	Page
CCS Transponder	50Z13017-005	603A636	24	21	504-505 507-515	164
Coaxial Switch	50M12357	601A563	4	31	201-203	130
Coaxial Switch	50Z12357-001	601A563	4	31	204-212 501-515	130
Coaxial Termination	50M12358	601A569	4	30	201-203	131
Coaxial Termination	50Z12358-001	601A569	4	30	204-212 501-515	131
Command Antenna Mod 309	50M10484	602A423	See Fig. 2		201	--
Command Antenna Mod 309	50M10484	602A433	See Fig. 2		201	--
Command Antenna Mod 313	50M12321	602A423			203	--
	50M12321	602A433			203	--
	50Z12321-001	602A578			204-211	--
	50Z12321-001	601A579			204-211	--
	50Z12321-003	602A578			212	--
	50Z12321-003	601A579			212	--
Command Decoder	50M12264	603A450	18	105	203-205 501-503 206-207	165
	50Z12705-001			105	504	
	or 50Z12705-005					
	50Z12705-003			107	208-212	
Command Directional Coupler	or 50Z12705-005				505	
	50Z12705-005				506-515	
	50M12382	603A562	17	89	201 & 203	166
	50Z12382-001				204	
Command Power Divider	or 50Z12382-003					
	50Z12382-003				205-212	
	50M10485	603A451	17	90	201	167
Command Power Divider	50M12173				203	
	50Z12173-001				204	
	or 50Z12173-003					
	50Z12173-003				205-212	

Table 1. Instrument Unit Component Alphabetical List (Continued)

Nomenclature	Part Number	Reference Designation	Loc. on Panel	Fig. 1 Loc. No.	Vehicle Effectivity	Page
Command Receiver	50M10697	603A449	18	98	201 & 203-210	168
	50Z10697-001				211-212	
Control Accelerometer (Pitch)	50M35022	601A25	2	15	201-209	110
Control Accelerometer (Pitch)	50Z35022-003	601A25	2	15	210-212	110
Control Accelerometer (Yaw)	50M35023	603A26	21	112	201-209	110
Control Accelerometer (Yaw)	50Z35023-003	603A26	21	112	210-212	110
Control Distributor	40M37210-001	603A2	18	97	201	77
	40M37217-001				202	
	40M37224-001				203	
	40Z37231-001				204	
	7910417-001				205	
	7910417-003				206	
	7910417-005				207	
	7910417-007				208	
	7910417-009				209	
	7910417-011				210	
	7910417-013				211	
	7910417-015				212	
	7910417-021				501	
	7910417-023				502	
	7910417-025				503	
	7910417-027				504	
	7910417-029				505	
7910417-031	506					
7910417-033	507					

Table 1. Instrument Unit Component Alphabetical List (Continued)

Nomenclature	Part Number	Reference Designation	Loc. on Panel	Fig. 1 Loc. No.	Vehicle Effectivity	Page	
Control Distributor	7910417-035	603A2	18	97	508	77	
	7910417-037				509		
	7910417-039				510		
	7910417-041				511		
	7910417-043				512		
	7910417-045				513		
	7910417-047				514		
	7910417-049				515		
Control-EDS Rate Gyros	50M35021	602A23	15	82 †	201-204	111	
	50M35021			90B †	501-502		
	50M35021-001			90B †	503		
	50M35021-003 or			82 †	205-212		
	50M35021-005			90B †	504-515		
Control Signal Processor	50M35500-011	602A24	15	83	501-503	112	
	50M35500-013				201-204		
	50Z35500-019 or				205-212		
	50M35500-023						
	50Z35500-021 or				504-515		
	50M35500-021						
Coolant Pump	20M42001-001	601A37	6	35	201-203	91	
	20M42001-001 or				204 & 501		
	20Z42001-001						
	20Z42001-001						
	20Z42001-001				44A		205 & 502
							206-211
							502-505
	7914878-001				212		
	7914878-003				506-507		
20Z42001-003	508-515						
† Physical location varies between vehicles, refer to Figure 1.							

Table 1. Instrument Unit Component Alphabetical List (Continued)

Nomenclature	Part Number	Reference Designation	Loc. on Panel	Fig. 1 Loc. No.	Vehicle Effectivity	Page	
Coolant Pump	20M42001-001	601A62	6	44B	206 & 502	91	
	20Z42001-001						
	7914878-001						
	20Z42001-003 or 7914878-003						
CPI Multiplexer Assembly Mod 270	50M12212-003	602A567	10	49†	201	135	
	50M12212-011						
	50M12212-015						
	50M12212-019	602A575	9	52 †	205		
	50Z12212-001						
	50Z13002-009	602A592	10	49 †	206		
	50Z13002-015						
	50Z13002-003						
	50Z13002-009	602A593					207-212
	DDAS/Computer Interface Unit	50M12216-001	603A447	17	92		203-204
50Z13007-001		603A447	17	92	205-212		
50Z13007-001		603A605	17	92	501-515		
DPI Multiplexer Assembly Mod 270	50M12212-001	602A446	9	52 †	201	135	
	50M12212-009						
	50M12212-013						
	50M12212-017	10	49 †	203			
	50Z12212-003						
	50Z13002-019	602A593	9	52 †	204		
	50Z13002-013						
	50Z13002-001						
	50Z13002-005	602A593					205
	50Z13002-021	602A592					206
EDS Distributor	40M37211-001	602A5	14	66	201	78	
	40M37218-001						
	40M37225-001						
	40Z37232-001						
	7910418-001						
	7910418-003						
	7910418-005						

† Physical location varies between vehicles, refer to Figure 1.



Table 1. Instrument Unit Component Alphabetical List (Continued)

Nomenclature	Part Number	Reference Designation	Loc. on Panel	Fig. 1 Loc. No.	Vehicle Effectivity	Page
EDS Distributor	7910418-007	602A5	14	66	208	78
	7910418-009				209	
	7910418-011				210	
	7910418-013				211	
	7910418-015				212	
	7910418-021				501	
	7910418-023				502	
	7910418-099				503	
	7910418-027				504	
	7910418-029				505	
	7910418-031				506	
	7910418-033				507	
	7910418-035				508	
	7910418-037				509	
	7910418-039				510	
	7910418-041				511	
	7910418-043				512	
	7910418-045				513	
	7910418-047				514	
7910418-049	515					
EDS Timer No. 1 (40 Second Timer)	40M37452-001	603A56	17	88	201 & 203	79
	7914540-001				205,207,& 209-212	
	40Z37452-001				204	
(30 Second Timer)	7915671-001				501-502 503-515	
EDS Timer No. 2 (20 Second Timer)	40Z37575-001	603A58	17	87	204 & 206 501-503	
EDS Timer No. 3 (60 Second Timer)	40Z37615-001	603A56	17	88	202, 206, & 208	
Electronic Controller Assembly	20Z42007-003	601A40	2	14	201-212 501-515	101
Environmental Conditioning Duct (Y Purge)	--	--	All	3		92
	20Z42100-001	--	--	--	201-203 205-212 501-515	--
	7915997-001	--	--	--	204	--
(Duct Assembly)	20Z42197-001	--	--	--	201-212 501-515	--

Table 1. Instrument Unit Component Alphabetical List (Continued)

Nomenclature	Part Number	Reference Designation	Loc. on Panel	Fig. 1 Loc. No.	Vehicle Effectivity	Page
Environmental Conditioning Duct (Flex Tubing)	20Z42101-003	--	--	--	--	--
	-005	--	--	--	--	--
	-007	--	--	--	--	--
	-009	--	--	--	--	--
	-011	--	--	--	--	--
( Tee)	7916199-001				505-515	92
Exciter Unit (Bottom)	50M12675	603A671	24	17	203	169
Exciter Unit (Top)	50M12675	603A672	24	17	203	169
First Stage Pressure Regulator	20Z42013	601A42	6	33	201-203	93
	20Z42013-003				205-211	
	20Z42013-007				204 & 501-515 212	
Flight Control Computer (IB)	50M32550-001	602A27	16	86	201-203 & 205	113
	50Z32550-007				204 & 208	
	50Z32550-003				206	
	50Z32550-005				207	
	50Z32550-009				205 & 209-212	
Flight Control Computer (V)	50M35300-009				501	
	50M35300-007				502	
	50M35300-011				503	
	50Z35300-001				504-515	
Force Balance Accelerometer	50M12390-001	603A464	21	113	201-204	124
	50M12370-001	603A463			501	
	50Z12390-001	603A464			201-204	
	50Z12370-001	603A463			501	
	50M12391-001	603A465			205-212	
	50M12391-001	603A466			502-515	
	50Z12391-001	603A465			502-515	
	50M12391-001	603A465			501	
	50M12391-001	603A466			501	
	50Z12391-001	603A465			205-212	
50Z12391-001	603A466			502-515		

Table 1. Instrument Unit Component Alphabetical List (Continued)

Nomenclature	Part Number	Reference Designation	Loc. on Panel	Fig. 1 Loc. No.	Vehicle Effectivity	Page
F1 RF Transmitter Assembly Mod I	50M12205-001	602A438	12	69	201-204	141
F1 RF Transmitter Assembly Mod II	50Z13011-007 50Z13011-001 50Z13011-007	602A643 602A589 602A589			205-212 501-502 503-515	
F1 Telemeter Assembly Mod B1	50M12206-001 50M12206-005 50M12206-007 50M12206-009 50Z13000-005 50Z13000-001 50Z13000-013	602A439    602A588  	12	73	201 202 203 204 205-212 501-503 504-515	133
F2 RF Transmitter Assembly Mod I	50M12205-003	602A444	9	54	201-204	141
F2 RF Transmitter Assembly Mod II	50Z13011-003 50Z13011-009	602A591 602A591	9 9	54 54	501-502 503	
F2 Telemeter Assembly Mod A3	50M12207-001 50M12207-005 50M12207-007 50M12207-009 50Z13001-001	602A443   602A590  	10	56	201 202 203 204 501-503	134

Table 1. Instrument Unit Component Alphabetical List (Continued)

Nomenclature	Part Number	Reference Designation	Loc. on Panel	Fig. 1 Loc. No.	Vehicle Effectivity	Page
Gas Bearing Heat Exchanger	20M42048	--	22	111 †	201-202	94
	20M42048-001	--	21	121 †	203	
	20M42048-001	--	21	124 †	204	
	20Z42048-001	--	21	124 †	205 & 501	
	7912296-001	--	21	123A †	206-212 502-515	
Gas Bearing Pressure Regulator	20Z42012	--	22	115	201-203	95
	20Z42012	--			205-212	
	or 20Z42012-003	--			204 & 501	
	20242012-003	--			502-515	
Gas Bearing Solenoid Valve	20Z42079	603A43	22	118 †	201-203	96
Gas Bearing Solenoid Valve	20Z42079-003	603A43	22	125 †	204-205	96
	20Z42079-005				501	
	or 20Z42079-003				206-207	
	20Z42079-005				208-212 502-515	
Hazardous Gas Manifold	--	601A57	7	42	201-203	97
Heat Exchanger Assembly	20Z42159-001	--	6	38	201-212 501-515	98
Lateral Accelerometer Slosch, Pitch, and Yaw	50M12552	603A555	23	119	203	125
Launch Vehicle Data Adapter	50M35011	603A29	19	96	201-212 501-515	114
Launch Vehicle Digital Computer	50M35010	603A28	19	101	201-212 501-515	115
† Physical location varies between vehicles, refer to Figure 1.						

Table 1. Instrument Unit Component Alphabetical List (Continued)

Nomenclature	Part Number	Reference Designation	Loc. on Panel	Fig. 1 Loc. No.	Vehicle Effectivity	Page
Longitudinal Accelerometer Orbital LH <sub>2</sub> Venting	50M12573	603A663	23	120	203	125
Low Pressure Switch	20M42131 20Z42016-001  20Z42016-005	603A44	22	116	201-203 204-208 501-503  209-212 504-515	99
Manual Shutoff Valve	20M42155-001	--	7	41	201-202	100A
Manual Shutoff Valve	20Z42155-001	--	7	41	203-212 501-515	100A
Measuring Distributor	40M37208-001 40M37209-001 40M37215-001 40M37216-001 40M37222-001 40M37223-001 40Z37229-001 40Z37230-001 7910416-001 7910415-001 7910416-003 7910415-003 7910416-005 7910416-007 7910416-009 7910416-011 7910416-013 7910416-015 7910416-021 7910415-021 7910416-023 7910415-023 7910416-025 7910415-025 7910416-027	602A3 602A4 602A3 602A4 602A3 602A4 602A3 602A4 602A3 602A3 602A4 602A3 602A4 602A3 602A4 602A3 602A4 602A3 602A4 602A3 602A4 602A3 602A4 602A3 602A4 602A3 602A4 602A3 602A4 602A3	10 13 10 13 10 13 10 13 10 10 13 10 13 10 10 13 10 10 13 10 13 10 13 10 13 10 13 10 13 10	48 67 48 67 48 67 48 67 48 67 48 67 48 67 48 67 48 67 48 67 48 67 48 67 48 67 48 67 48 67 48	201 201 202 202 203 203 204 204 205 205 206 206 207 208 209 210 211 212 501 501 502 502 503 503 504	80

Table 1. Instrument Unit Component Alphabetical List (Continued)

Nomenclature	Part Number	Reference Designation	Loc. on Panel	Fig. 1 Loc. No.	Vehicle Effectivity	Page	
Measuring Rack A402	50M12525-003	601A402	1	5 †	201	126	
	50M12272-007				202		
	50M12272-009	—	—	—	203		
	50Z12272-011				204		
	50Z12272-013	602A402	9	50 †	205		
	50Z12272-015				206		
	50Z12272-017				207		
	50Z12272-019				208		
	50Z12272-021				209		
	50Z12272-023				210		
	50Z12272-025				211		
	50Z12272-027	—	—	—	212		
	50M12272-005	601A402	1	5 †	501		
	50Z12272-029				502		
	50Z12272-031	—	—	—	503		
	50Z12272-033	602A402	9	50 †	504		
	50Z12272-035				505		
	50Z12272-037				506		
	50Z12272-039				507		
	50Z12272-041				508		
	50Z12272-043				509		
	50Z12272-045				510		
	50Z12272-047				511		
	50Z12272-049				512		
	50Z12272-051				513		
	50Z12272-053				514		
	50Z12272-055	—	—	—	515		
	Measuring Rack A403	50M12273-001	602A403	11	47 †		201
		50M12273-007					202
		50M12273-009					203
50Z12273-011					204		
50Z12273-013					205		
50Z12273-015			15	85 †	206		
50Z12273-017					207		
50Z12273-019					208		
50Z12273-021					209		
50Z12273-023					210		
50Z12273-025					211		
50Z12273-027		—	—	—	212		
† Physical location varies between vehicles, refer to Figure 1.							

Table 1. Instrument Unit Component Alphabetical List (Continued)

Nomenclature	Part Number	Reference Designation	Loc. on Panel	Fig. 1 Loc. No.	Vehicle Effectivity	Page	
Measuring Rack A 403	50M12273-005	602A403	11	47 †	501	126	
	50Z12273-029				502		
	50Z12273-031				503		
	50Z12273-033			15	90A †		504
	50Z12273-035						505
	50Z12273-037						506
	50Z12273-039						507
	50Z12273-041						508
	50Z12273-043						509
	50Z12273-045						510
	50Z12273-047						511
	50Z12273-049						512
	50Z12273-051						513
	50Z12273-053						514
	50Z12273-055						515
Measuring Rack A404	50M12274-001	602A404	13	68 †	201	126	
	50M12274-007				202		
	50M12274-009				203		
	50Z12274-011				204		
	50Z12274-013				205		
	50Z12274-015			15	84 †		206
	50Z12274-017						207
	50Z12274-019						208
	50Z12274-021						209
	50Z12274-023						210
	50Z12274-025						211
	50Z12274-027						212
	50M12274-005			13	68 †		501
	50Z12274-029						502
	50Z12274-031						503
	50Z12274-033				84 †		504
	50Z12274-035						505
	50Z12274-037						506
	50Z12274-039						507
	50Z12274-041						508
	50Z12274-043						509
	50Z12274-045						510
	50Z12274-047						511
	50Z12274-049						512
	50Z12274-051						513
	50Z12274-053						514
	50Z12274-055						515

† Physical location varies between vehicles, refer to Figure 1.

Table 1. Instrument Unit Component Alphabetical List (Continued)





Nomenclature	Part Number	Reference Designation	Loc. on Panel	Fig. 1 Loc. No.	Vehicle Effectivity	Page		
Measuring Rack A405 	50M12275-001	602A405	9	50	201	126		
	50M12275-007				202			
	50M12275-009				203			
	50Z12275-011				204			
	50Z12275-015				13		68 †	206
	50M12275-005				9		50	501
	50Z12275-029				502			
	50Z12275-031				503			
Measuring Rack A406 	50M12276-001	602A406	15	85 †	201			
	50M12276-007				202			
	50M12276-009				203			
	50M12276-011				204			
	50Z12276-015				13		78A †	206
	50M12276-005				15		90A †	501
	50Z12276-029				502			
	50Z12276-031				503			
Measuring Rack A407 	50M12277-001	602A407	14	78	201			
	50M12277-007				202			
	50M12277-009				203			
	50Z12277-011				204			
	50M12277-005				501			
	50Z12277-029				502			
	50Z12277-031				503			
Measuring Rack A408 	50M12278-001	602A408	14	77	201			
	50M12278-007				202			
	50M12278-009				203			
	50Z12278-011				204			
	50M12278-005				501			
	50Z12278-029				502			
	50Z12278-031				503			
Measuring Rack A409 	50M12279-001	602A409	15	84	201			
	50M12279-007				202			
	50M12279-009				203			
	50Z12279-011				204			
	50M12279-005				501			
	50Z12279-029				502			
	50Z12279-031				503			
† Physical location varies between vehicles, refer to Figure 1.								



Table 1. Instrument Unit Component Alphabetical List (Continued)

Nomenclature	Part Number	Reference Designation	Loc. on Panel	Fig. 1 Loc. No.	Vehicle Effectivity	Page
Measuring Rack A669	50M12667-005	603A669	23	122	501	126
	50Z12667-029				502	
	50Z12667-031				503	
Measuring Rack Selector	50M12270-001	601A400	1	12	201-203 501	128
Measuring Rack Selector	50Z12270-001	601A400	1	12	204-212 502-515	128
Methanol-Water Accumulator	20Z42040-001	--	6	34	201-203	100
	7914398-001	--			204-205	
	7915880-001	--			501-503 206-212 504-515	
Modulating Flow Control Valve	20Z42007-001	601A39	6	39	201-212 501-515	101
Mounting and Thermal Condi- tioning Panels	20Z42000-001	--	--	--	201-212 501-515	100B
PCM Trans- mitting Antenna Mod 609	50M13018-001	601A633	See Fig. 2		501-503	--
PCM Trans- mitting Antenna Mod 609	50Z13018-001	601A633	See Fig. 2		504	--
PCM/CCS Transmitting Antenna Mod 613	50M12664-001	602A585	See Fig. 2		501-503	--
	50Z12664-001	602A585			504-515	--
	50M12664-001	603A625			501-503	--
	50Z12664-001	603A625			504-515	--
PCM Coaxial Switch Mod 612	50M13016	603A630	24	24	501	136
	50M13016-001				502-503	
	50Z13016-001				504	

Table 1. Instrument Unit Component Alphabetical List (Continued)

Nomenclature	Part Number	Reference Designation	Loc. on Panel	Fig. 1 Loc. No.	Vehicle Effectivity	Page
PCM/DDAS Telemeter Assembly Mod 301	50M12210-001	602A420	12	70	201	137
	50M12210-005				202	
	50M12210-007				203	
	50M12210-009				204	
	50Z13005-005				205-207	
	50Z13005-007				208-212	
	50Z13005-001	602A595			501-503	
	50Z13005-007	602A595			504-515	
	Plug Type J-Box Assembly	40M33012-001	603A54	20	102	
40M33032-001					202	
40M33052-001					203	
40Z33072-001					204-212	
					501-515	
Power Distributor	40M37212-001	601A1	2	2	201	82
	40M37219-001				202	
	40M37226-001				203	
	40Z37233-001				204	
	7910419-001				205	
	7910419-003				206	
	7910419-005				207	
	7910419-007				208	
	7910419-009				209	
	7910419-011				210	
	7910419-013				211	
	7910419-015				212	
	7910419-021				501	
	7910419-023				502	
	7910419-025				503	
	7910419-027				504	
	7910419-029				505	
	7910419-031				506	
	7910419-033				507	
	7910419-035				508	
	7910419-037				509	
	7910419-039				510	
	7910419-041				511	
	7910419-043				512	
	7910419-045				513	
	7910419-047				514	
	7910419-049				515	

Table 1. Instrument Unit Component Alphabetical List (Continued)

Nomenclature	Part Number	Reference Designation	Loc. on Panel	Fig. 1 Loc. No.	Vehicle Effectivity	Page
P1 PCM/RF Transmitter Assembly CT-19B	50M12211-001	602A421	13	74	201-202	138
P1 PCM/RF Transmitter Assembly Mod II	50M12421-001	602A571	13	79 †	203-204	138
	50Z13012-005	602A571	11	62 †	205-212	
	50Z13012-001	602A600	13	79 †	501-502	
	50Z13012-005	602A600	13	79 †	503	
	50Z13012-007	602A600	13	79 †	504-515	
Remote Digital Multiplexer Mod 410	50M12214-001	603A455	18	100	201	139
	50M12214-005				202	
	50M12214-007				203	
	50M12214-009				204	
Remote Digital Multiplexer J Mod 410	50Z13006-005	602A615	11	59	205-207	
	50Z13006-007	602A615	11	59	208-212	
	50Z13006-001	603A599	17	91 †	501-503	
	50Z13006-007	603A599	11	59 †	504-515	
Remote Digital Multiplexer K Mod 410	50Z13006-003	603A455	18	100	205-212	
Remote Digital Multiplexer K Mod 410	50Z13006-003	603A594	18	106	501-505	
	50Z13006-009	603A594	18	106	506-515	
Remote Digital Submultiplexer	50M12213-001	603A431	17	81	201-204	140
Retroreflector Assembly	50M22108-001	--	See Fig. 2		202-205 501	116
Retroreflector Assembly	50Z22108	--			206-212 502-515	116
S-Band Power Amplifier	50M12676	603A673	24	16	203	170
S-Band Power Amplifier	50M12676	603A674	24	18	203	170

† Physical location varies between vehicles, refer to Figure 1.

Table 1. Instrument Unit Component Alphabetical List (Continued)

Nomenclature	Part Number	Reference Designation	Loc. on Panel	Fig. 1 Loc. No.	Vehicle Effectivity	Page
Secure Range Safety Decoder	50M10698	603A568	18	99	201	171
Segment (Access Door)	30Z13101-001	Unit 601	--	--	201-212 501-515	72F
Segment (ST-124M)	30Z13102-001	Unit 603	--	--	201-212 501-515	72F
Segment	30Z13103-001	Unit 602	--	--	201-212 501-515	72F
Slow Speed Multiplexer Assembly Mod 245	50M12208-001	602A442	11	45	201	142
	50M12208-005				202	
	50M12208-007	50M12208-009	11	45	203	
	50M12208-009				204	
	50Z13003-005				602A598	
Source Follower	50M12413-001	601A472	1	13	201-204 501-503	143
Splice Plates	Ref. Page 72G	--	See Fig. 2		501-515	72G
ST-124M-3 Inertial Platform Assembly	50M22100-005	603A19	21	114	201-206	117
	50M22100-007				501-502	
	50M22100-009				207	
	50M22100-015				503	
	50M22100-013				208 & 212	
ST-124M-3 Platform AC Power Supply	50M22106-001	603A13	20	103	201	118
	50M22106-005				202-204	
	50M22106-007				501	
	50M22106-009				205-206	
					502-503	
	207-212					
	504-515					

Table 1. Instrument Unit Component Alphabetical List (Continued)

Nomenclature	Part Number	Reference Designation	Loc. on Panel	Fig. 1 Loc. No.	Vehicle Effectivity	Page
ST-124M-3 Platform Electronic Assembly	50M22102-005	603A20	20	95	201	119
	50M22102-007				202-204	
	50M22102-011				501	
	50M22102-013				205-206	
	50M22102-015				502	
	50M22102-017				503	
	50M22102-019				207 & 212	
					506-515	
					208-209	
					210-211	
					504-506	
Switch Selector Mod I	50M64008	603A17	17	80	201	83
Switch Selector Mod II	50M67864-005	603A17	17	80	202-212 501-515	83
S1 RF Trans- mitter Assembly Mod I	50M12205-005	602A441	11	57	201-204	141
S1 RF Trans- mitter Assembly Mod II	50Z13011-005	602A597	11	57	501-502	141
	50Z13011-011	602A597	11	57	503	141
S1 Telemeter Assembly	50Z12209-001	602A440	11	58	201-203	144
S1 Telemeter Assembly Mod 601	50M13004-001	602A440	11	58	204	144
S1 Telemeter Assembly Mod 601	50Z13004-001	602A596	11	58	501-503	144
Tape Recorder (Airborne)	50M12410-001	602A419	11	46	201-204	145
Tape Recorder (Airborne)	50Z13010-001	602A604	11	46	501-503	145
Telemetry Antenna Mod 219	50M12284	602A452	See Fig. 2		201-202	--

Table 1. Instrument Unit Component Alphabetical List (Continued)

Nomenclature	Part Number	Reference Designation	Loc. on Panel	Fig. 1 Loc. No.	Vehicle Effectivity	Page
Telemetry Antenna Mod 219	50M12284	603A453	See Fig. 2		201-202	--
Telemetry Antenna Mod 223	50M12500	602A580	See Fig. 2		203	--
	50M12500	602A581			203	--
	50Z12500-001	602A580			204-212	--
	50Z12500-001	602A581			501-515	--
					204-212	--
					501-515	
Telemetry Calibrator	50M12416-001	602A437	13	76 †	201-204	146
	50Z13008-001	602A602	13	76 †	501-503	
	50Z13008-003	602A644	11	64 †	205-212	
	50Z13008-005	602A644	11	64 †	504-509	
Telemetry Calibrator Power and Control Assembly	50M12404-001	602A566	13	75 †	201-204	
	50Z13009-001	602A566	11	63 †	205-212	
	50Z13009-001	602A603	13	75 †	501-515	
Telemetry Directional Coupler Mod 226	50M12586-001	602A668	10	65	205	147
Telemetry Directional Coupler Mod 226	50Z12586-001	602A668	10	65	206-212	147
					504-515	
Telemetry Power Divider	50M12495	601A436	4	29	201-203	148
	50Z12495-001	601A436	4	29	204	
	50Z12495-003	601A436	4	29	205-212	
					501-515	
Telemetry RF Coupler	50M12497-001	602A445	9	53	201-203	149
Telemetry RF Coupler Mod 451	50Z12497-001	602A445	9	60	204-212	149
					501-515	
Temperature Sensor	20Z42007-005	--	--	--	201-212	101
					501-515	

† Physical location varies between vehicles, refer to Figure 1.

Table 1. Instrument Unit Component Alphabetical List (Continued)

Nomenclature	Part Number	Reference Designation	Loc. on Panel	Fig. 1 Loc. No.	Vehicle Effectivity	Page
Thermal Conditioning Panel Heaters	40M37641-001	601A66	1	20A	501-503	102A
	or					
	40Z37641-001	601A67	1	20B	501-503	
		601A68	2	15A	501-503	
		601A69	2	20C	501-503	
		603A75	17	90C	501-503	
		603A76	17	90D	501-503	
	603A77	23	123B	501-503		
Thermal Expansion Chamber	20Z42163-001	--	7	32A	201-212 501-515	102

Table 1. Instrument Unit Component Alphabetical List (Continued)

Nomenclature	Part Number	Reference Designation	Loc. on Panel	Fig. 1 Loc. No.	Vehicle Effectivity	Page
TV Antenna	50M12411	601A646	See Fig. 2	202	--	
TV Antenna	50M12411	601A647	See Fig. 2	202	--	
TV Antenna Mod 613	50M12664	601A614	See Fig. 2	203	--	
TV Antenna Mod 613	50M12664-001	601A617	See Fig. 2	203	--	
TV Camera	50M12575	*	*	--	202	172
	50M12583	*	*	--	203	
	50M12584	*	*	--	203	
TV Junction Box	50M12352	603A652	24	6	202	173
TV Power Amplifier	50M12571	603A649	24	8	202	174
TV Power Divider	50M12408	603A651	24	7	202	175
TV Transmitter Assembly	50M12570	602A648	24	9	202	176
Two-Cubic-Foot Sphere	20Z32013-001	603A525	22	117	201-212 501-515	103
UHF/RF Filter	50M12668	603A670	23	123	503	150
* On vehicle 202, this component is located on payload. On vehicle 203, this component is located on S-IVB LH <sub>2</sub> tank.						



Table 1. Instrument Unit Component Alphabetical List (Continued)

Nomenclature	Part Number	Reference Designation	Loc. on Panel	Fig. 1 Loc. No.	Vehicle Effectivity	Page
UHF/RF Transmitter Assembly	50M13013-001	603A601	24	23	501-503	151
	50Z13013-001	—	—	—	504	—
Umbilical Door	30Z13008-001	--	7	--	201-202 501-515	72H
Umbilical Plate Assembly	11Z00055-001	--	—	41A	201-212	—
	11Z00014-005	--		—	501-504	
	11Z00014-007	--		—	505-506	
	11Z00014-009	--		—	507-515	
VSWR Measuring Assembly Mod 220	50M10683	602A448	10	55	201-202	152
VSWR Measuring Assembly Mod 225	50Z12555-001	602A642	10	61	203-204 501-503	152
Water Accumulator Assembly	20Z42196-001	--	6	37	201-205 501	104
	7915984-001	--	3	27A	206-212 502-515	—
Water Solenoid Valve	20Z42034-001	601A41	6	36	201-202	105
			6	43	203-205 501	
			3	27B	206-208	
			6	44C	209-212 502-515	
5 Volt Measuring Voltage Supply	40Z20964	602A16	12	72	201-212 501-515	84
50-Cubic-Inch Spheres	20Z42039-001	--	6	40	201-205	106
56 Volt Power Supply	40Z20807-003	601A15	1	11	201-212 501-515	85
165-Cubic-Inch Sphere	7910120-003	--	6	44	206-212 501-515	106

**TABLE 2 AND 3  
PART NUMBERS**

Table 2. Instrument Unit Component Numerical Listing

Part Number	Nomenclature	Page
10Z22257-001	Cable Tray	72E
11Z00014-005 -007 -009	Umbilical Plate Assembly	72H
11Z00055-001		
20Z32013	Two-Cubic-Foot Sphere	104
20M42001-001	Coolant Pump	91
20M42048	Gas Bearing Heat Exchanger	94
20M42048-001	Gas Bearing Heat Exchanger	
20M42155-001	Manual Shutoff Valve	100A
20Z42000-001	Mounting and Thermal Conditioning Panels	100B
20Z42001-001 -003	Coolant Pump	91
20Z42007-001	Modulating Flow Control Valve	101
20Z42007-003	Electronic Controller Assembly	
20Z42007-005	Temperature Sensor	
20Z42012-003	Gas Bearing Pressure Regulator	95
20Z42013-003 -007	First Stage Pressure Regulator	93
20Z42016-001	Low Pressure Switch	99
20Z42034-001	Water Solenoid Valve	105
20Z42039-001	50-Cubic-Inch Spheres	106
20Z42040-001	Methanol-Water Accumulator	100
20Z42048-001	Gas Bearing Heat Exchanger	94

Table 2. Instrument Unit Component Numerical Listing (Continued)

Part Number	Nomenclature	Page
20Z42079-003	Gas Bearing Solenoid Valve	96
-005		
20Z42100-001	Y Purge	92
20Z42101-003	Flex Tubing	92
-005		
-007		
-009		
-011		
20Z42155-001	Manual Shutoff Valve	100A
20Z42159-001	Heat Exchanger Assembly	98
20Z42163-001	Thermal Expansion Chamber	102
20Z42170-001	Methanol-Water Accumulator	100
20Z42196-001	Water Accumulator Assembly	104
20Z42197-001	Duct Assembly	92
30Z13008-001	Umbilical Door	72H
30Z13101-001	Segment (Unit 601)	72F
30Z13102-001	Segment (Unit 603)	72F
30Z13103-001	Segment (Unit 602)	72F
40M20780-001	Battery D10, D20, D30, D40	76
-003		
-005		
-007		
40M33012-001	Plug Type J-Box	81
40M33032-001	Plug Type J-Box	
40M33052-001	Plug Type J-Box	
40M33072-001	Plug Type J-Box	
40M37208-001	Measuring Distributor	80
40M37209-001	Measuring Distributor	
40M37210-001	Control Distributor	77

Table 2. Instrument Unit Component Numerical Listing (Continued)

Part Number	Nomenclature	Page
40M37211-001	EDS Distributor	78
40M37212-001	Power Distributor	82
40M37213-001	Auxiliary Power Distributor	75
40M37214-001	Auxiliary Power Distributor	75
40M37215-001	Measuring Distributor	80
40M37216-001	Measuring Distributor	80
40M37217-001	Control Distributor	77
40M37218-001	EDS Distributor	78
40M37219-001	Power Distributor	82
40M37220-001	Auxiliary Power Distributor	75
40M37221-001	Auxiliary Power Distributor	75
40M37222-001	Measuring Distributor	80
40M37223-001	Measuring Distributor	80
40M37224-001	Control Distributor	77
40M37225-001	EDS Distributor	78
40M37226-001	Power Distributor	82
40M37227-001	Auxiliary Power Distributor	75
40M37228-001	Auxiliary Power Distributor	75
40M37452-001	EDS Timer No. 1 (40 Second Timer)	79
40M37615-001	EDS Timer No. 3 (60 Second Timer)	79
40Z20780-001	Battery D10, D20, D30, D40	76
40Z20807-003	56 Volt Power Supply	85

Table 2. Instrument Unit Component Numerical List (Continued)

Part Number	Nomenclature	Page
40Z20964	5 Volt Measuring Voltage Supply	84
40Z33072-001	Plug Type J-Box Assembly	81
40Z37229-001	Measuring Distributor	80
40Z37230-001	Measuring Distributor	
40Z37231-001	Control Distributor	77
40Z37232-001	EDS Distributor	78
40Z37233-001	Power Distributor	82
40Z37234-001	Auxiliary Power Distributor	75
40Z37235-001	Auxiliary Power Distributor	
40Z37452-001	EDS Timer No. 1 (40 Second Timer)	79
40Z37575-001	EDS Timer No. 2 (20 Second Timer)	
40Z37615-001	EDS Timer No. 3 (60 Second Timer)	
50M10224	Lights (TV) (4)	--
50M10347	C-Band Antenna Mod 708	--
50M10484	Command Antenna Mod 309	--
50M10485	Command Power Divider	167
50M10683	VSWR Measuring Assembly Mod 220	152
50M10697	Command Receiver	168
50M10698	Secure Range Safety Decoder	171
50M12173	Command Power Divider	167
50M12205-001	F1 RF Transmitter Assembly Mod I	141
50M12205-003	F2 RF Transmitter Assembly Mod I	
50M12205-005	S1 RF Transmitter Assembly Mod I	

Table 2. Instrument Unit Component Numerical Listing (Continued)

Part Number	Nomenclature	Page
50M12206-001 -005 -007 -009	F1 Telemeter Assembly Mod B1	133
50M12207-001 -005 -007 -009	F2 Telemeter Assembly Mod A3	134
50M12208-001 -005 -007 -009	Slow Speed Multiplexer Mod 245	142
50M12209-001	S1 Telemeter Assembly	144
50M12210-001 -005 -007 -009	PCM/DDAS Telemeter Assembly Mod 301	137
50M12211-001	P1 PCM/RF Transmitter Assembly CT-19B	138
50M12212-001 -009 -013 -017	DP1 Multiplexer Assembly Mod 270	135
50M12212-003 -011 -015 -019	CP1 Multiplexer Assembly Mod 270	135
50M12213-001	Remote Digital Submultiplexer	140
50M12214-001 -005 -007 -009	Remote Digital Multiplexer Mod 410	139
50M12216-001	DDAS/Computer Interface Unit	132
50M12261-001	C-Band Transponder	159

Table 2. Instrument Unit Component Numerical Listing (Continued)

Part Number	Nomenclature	Page
50M12264	Command Decoder	165
50M12266-001	Azusa Transponder Type C	157
50M12267-001	Azusa RI Filter Assembly	156
50M12270-001	Measuring Rack Selector	128
50M12271-001 -005 -007 -009	Measuring Rack A401	126
50M12272-005 -007 -009	Measuring Rack A402	
50M12273-001 -005 -007 -009	Measuring Rack A403	
50M12274-001 -005 -007 -009	Measuring Rack A404	
50M12275-001 -005 -007 -009	Measuring Rack A405	
50M12276-001 -005 -007 -009	Measuring Rack A406	
50M12277-001 -005 -007 -009	Measuring Rack A407	



Table 2. Instrument Unit Component Numerical Listing (Continued)

Part Number	Nomenclature	Page
50M12278-001	Measuring Rack A408	126
-005		
-007		
-009		
50M12279-001	Measuring Rack A409	
-005		
-007		
-009		
50M12284	Telemetry Antenna Mod 219	--
50M12321	Command Antenna Mod 313	--
50M12352	Junction Box (TV)	173
50M12357	Coaxial Switch	130
50M12358	Coaxial Termination	131
50M12370-001	Force Balance Accelerometer	124
50M12382	Command Directional Coupler	166
50M12390-001	Force Balance Accelerometer	124
50M12391-001	Force Balance Accelerometer	124
50M12404-001	Telemeter Calibrator Power and Control Assembly	146
50M12408	TV Power Divider	175
50M12410-001	Tape Recorder (Airborne)	145
50M12411	TV Antenna	--
50M12413-001	Source Follower	143
50M12416-001	Telemetry Calibrator	146
50M12421-001	P1 PCM/RF Transmitter Assembly	138

Table 2. Instrument Unit Component Numerical Listing (Continued)

Part Number	Nomenclature	Page
50M12495	Telemetry Power Divider	148
50M12497-001	Telemetry RF Coupler	149
50M12500	Telemetry Antenna Mod 223	--
50M12501	PCM/CCS Antenna	--
50M12504	C-Band Antenna Mod 713	--
50M12504-001	C-Band Antenna Mod 713	--
50M12520	Camera Control Unit (Kintel)	158
50M12521	Camera Control Unit (GEC)	158
50M12525-003	Measuring Rack A402	126
50M12527	CCS Power Divider	163
50M12552	Lateral Accelerometer Slosh, Pitch, and Yaw	125
50M12555	VSWR Measuring Assembly Mod 225	152
50M12570	TV Transmitter Assembly	176
50M12571	TV Power Amplifier	174
50M12573	Longitudinal Accelerometer Orbital LH <sub>2</sub> Venting	125
50M12575	TV Camera	172
50M12583	TV Camera	172
50M12584	TV Camera	172
50M12586	Telemetry Directional Coupler	147
50M12664-001	PCM/CCS Antenna	--
50M12664	TV Antenna Mod 613	--
50M12668	UHF/RF Filter	150

Table 2. Instrument Unit Component Numerical Listing (Continued)

Part Number	Nomenclature	Page
50M12673	CCS Power Amplifier	162
50M12675	Exciter Unit	169
50M12676	TV Power Amplifier	174
50M13004-001	S1 Telemeter Assembly Mod 601	144
50M13015	CCS Hybrid Ring	161
50M13016-001	PCM Coaxial Switch	136
50M13016-001	CCS Coaxial Switch	160
50M13017-003	CCS Transponder	164
50M13018-001	CCS Directional Antenna Mod 609	--
50M13018-001	PCM Transmitting Antenna Mod 609	--
50M13019-001	CCS Receiving Antenna Mod 610	--
50M13022	Telemetry RF Coupler Mod 451	149
50M22100-005 -007 -009 -013 -015	ST-124M-3 Inertial Platform Assembly	117
50M22102-005 -007 -011 -013 -015 -017 -019	ST-124M-3 Platform Electronic Assembly	119

Table 2. Instrument Unit Component Numerical Listing (Continued)

Part Number	Nomenclature	Page
50M22106-005 -007 -009	ST-124M-3 Platform AC Power Supply	118 
50M22107-003 -005 -009	Accelerometer Signal Conditioner	109 
50M22108-001	Retroreflector Assembly	116
50M32550-001	Flight Control Computer IB	113
50M35010	Launch Vehicle Digital Computer	115
50M35011	Launch Vehicle Data Adapter	114
50M35021 -001 -003 -005	Control-EDS Rate Gyros    -----	111  
50M35022	Control Accelerometer (pitch)	110 
50M35023	Control Accelerometer (yaw)	
50M35300-007 -009 -011	Flight Control Computer V	113 
50M35500-007 -011 -013 -019 -021 -023	Control Signal Processor    -----	112  
50M64008	Switch Selector Mod I	83

Table 2. Instrument Unit Component Numerical Listing (Continued)

Part Number	Nomenclature	Page
50M67864-005	Switch Selector Mod II	83
50Z10697-001	Command Receiver	168
50Z12173-001	Command Power Divider	167
50Z12206-001	F1 Telemeter Assembly Mod B1	133
50Z12212-001	CP1 Multiplexer Assembly Mod 270	135
50Z12212-003	DP1 Multiplexer Assembly Mod 270	
50Z12261	C-Band Transponder	159
50Z12270-001	Measuring Rack Selector	128
50Z12271-011	Measuring Rack A401	128
-013		
-015		
-017		
-019		
-021		
-023		
-025		
-027		
-029		
-031		
-033		
-035		
-037		
-039		
-041		
-043		
-045		
-047		
-049		
-051		
-053		
-055		
50Z12272-011	Measuring Rack A402	
-013		
-015		
-017		
-019		

Table 2. Instrument Unit Component Numerical Listing (Continued)

Part Number	Nomenclature	Page
50Z12272-021 -023 -025 -027 -029 -031 -033 -035 -037 -039 -041 -043 -045 -047 -049 -051 -053 -055	Measuring Rack A402	126
50Z12273-011 -013 -015 -017 -019 -021 -023 -025 -027 -029 -031 -033 -035 -037 -039 -041 -043 -045 -047 -049 -051 -053 -055	Measuring Rack A403	
50Z12274-011 -013 -015	Measuring Rack A404	

Table 2. Instrument Unit Component Numerical Listing (Continued)

Part Number	Nomenclature	Page
50Z12274-017 -019 -021 -023 -025 -027 -029 -031 -033 -035 -037 -039 -041 -043 -045 -047 -049 -051 -053 -055	Measuring Rack A404	126
50Z12275-011 -015 -029 -031	Measuring Rack A405	
50Z12276-011 -015 -029 -031	Measuring Rack A406	
50Z12277-011 -029 -031	Measuring Rack A407	
50Z12278-011 -029 -031	Measuring Rack A408	
50Z12279-011 -029 -031	Measuring Rack A409	
50Z12321-001	Command Antenna Mod 313	--
50Z12333-001	Azusa Antenna Mod 711	--

Table 2. Instrument Unit Component Numerical Listing (Continued)

Part Number	Nomenclature	Page
50Z12357-001	Coaxial Switch	130
50Z12358-001	Coaxial Termination	131
50Z12370-001	Force Balance Accelerometer	124
50Z12382-001 -003	Command Directional Coupler	166
50Z12390-001	Force Balance Accelerometer	124
50Z12391-001	Force Balance Accelerometer	124
50Z12404-001	Telemetry Calibrator Power and Control Assembly	146
50Z12495-001 -003	Telemetry Power Divider	148
50Z12497-001	Telemetry RF Coupler	149
50Z12500-001	Telemetry Antenna Mod 223	--
50Z12504-001	C-Band Antenna Mod 713	--
50Z12527-001	CCS Power Divider	163
50Z12555-001	VSWR Measuring Assembly Mod 225	152
50Z12574-001 -003 -005	C-Band Transponder	159
50Z12586-001	Telemetry Directional Coupler	147
50Z12664-001	PCM/CCS Antenna	--
50Z12667-005 -029 -031	Measuring Rack A669	126
50Z12668	UHF/RF Filter	150
50Z12673-001 -003	CCS Power Amplifier	162
50Z12705-001 -003 -005	Command Decoder	165



Table 2. Instrument Unit Component Numerical Listing (Continued)

Part Number	Nomenclature	Page
50Z12754-001 -003 -005	C-Band Transponder	159
50Z13000-001 -005 -009	F1 Telemeter Assembly Mod B1	133
50Z13001-001	F2 Telemeter Assembly Mod A3	134
50Z13002-003 -009 -015	CP1 Multiplexer Assembly Mod 270	135
50Z13002-001 -005 -013 -017 -019 -021	DP1 Multiplexer Assembly Mod 270	135
50Z13003-005	Slow Speed Multiplexer Mod 245	142
50Z13004-001	S1 Telemeter Assembly Mod 601	144
50Z13005-001 -005 -007	PCM/DDAS Telemeter Assembly Mod 301	137
50Z13006-001 -005 -007	Remote Digital Multiplexer J Mod 410	139
50Z13006-003 -009	Remote Digital Multiplexer K Mod 410	139
50Z13007-001	DDAS/Computer Interface Unit	132
50Z13008-001 -003 -005	Telemetry Calibrator	146
50Z13009-001	Telemetry Calibrator Power and Control Assembly	146
50Z13010-001	Tape Recorder (Airborne)	145

Table 2. Instrument Unit Component Numerical Listing (Continued)

Part Number	Nomenclature	Page
50Z13011-001 -007	F1 RF Transmitter Assembly Mod II	141
50Z13011-003 -009	F2 RF Transmitter Assembly Mod II	
50Z13011-005 -011	S1 RF Transmitter Assembly Mod II	
50Z13012-001 -005 -007	P1 PCM/RF Transmitter Assembly Mod II	
50Z13013-001	UHF/RF Transmitter Assembly	151
50Z13015-001	CCS Hybrid Ring	161
50Z13016-001	PCM Coaxial Switch	136
50Z13016-001	CCS Coaxial Switch	160
50Z13017-005	CCS Transponder	164
50Z13018-001	PCM Transmitting Antenna Mod 609	--
50Z13018-001	CCS Directional Antenna Mod 609	--
50Z13019-001	CCS Receiving Antenna Mod 610	--
50Z22108	Retroreflector Assembly	116
50Z32550-001 -003 -005 -007	Flight Control Computer (IB)	113
50Z35021-003	Control-EDS Rate Gyros	111
50Z35022-003	Control Accelerometer (pitch)	110
50Z35023-001	Control Accelerometer (yaw)	
50Z35300-001	Flight Control Computer (V)	113
50Z35500-011 -013 -015	Control Signal Processor	112
7910120-003	165-Cubic-Inch Sphere	106
7910415-001 -003 -021 -023 -025	Measuring Distributor	80

Table 2. Instrument Unit Component Numerical Listing (Continued)

Part Number	Nomenclature	Page
7910416-001 -003 -005 -007 -009 -011 -013 -015 -021 -023 -025 -027 -029 -031 -033 -035 -037 -039 -041 -043 -045 -047 -049	Measuring Distributor	80
7910417-001 -003 -005 -007 -009 -011 -013 -015 -021 -023 -025 -027 -029 -031 -033 -035 -037 -039 -041 -043 -045	Control Distributor	77

Table 2. Instrument Unit Component Numerical Listing (Continued)

Part Number	Nomenclature	Page
7910417-047 -049	Control Distributor	77
7910418-001 -003 -005 -007 -009 -011 -013 -015 -021 -023 -025 -027 -029 -031 -033 -035 -037 -039 -041 -043 -045 -047 -049 -099	EDS Distributor	78
7910419-001 -003 -005 -007 -009 -011 -013 -015 -021 -023 -025 -027 -029 -031 -033 -035 -037	Power Distributor	82

Table 2. Instrument Unit Component Numerical Listing (Continued)

Part Number	Nomenclature	Page
7910419-039 -041 -043 -045 -047 -049	Power Distributor	82
7910420-001 -003 -005 -007 -009 -011 -013 -015 -021 -023 -025 -027 -029 -031 -033 -035 -037 -039 -041 -043 -045 -047 -049	Auxiliary Power Distributor	75
7910421-001 -003 -005 -007 -009 -011 -013 -015 -021 -023 -025 -027 -029 -031	Auxiliary Power Distributor	

Table 2. Instrument Unit Component Numerical Listing (Continued)

Part Number	Nomenclature	Page
7910421-033 -035 -037 -039 -041 -043 -045 -047 -049	Auxiliary Power Distributor	75
7912296-001	Gas Bearing Heat Exchanger	94
7914398	Methanol-Water Accumulator	100
7914540-001	EDS Timer No. 1 (40 Second Timer)	79
7914878-001 -003	Coolant Pump	91
7915671-001	EDS Timer No. 1 (30 Second Timer)	79
7915880-001	Methanol-Water Accumulator	100
7915984-001	Water Accumulator Assembly	104
7915997-001	Y Purge	92
7916199-001	Tee	92

FIGURES 1 AND 2

**FIGURE 1 COMPONENT NOMENCLATURE BY CALLOUT NUMBER**

- |  |  |
|--|--|
| 1. Measuring Rack A401                 | 20B. Thermal Conditioning Panel Heater |
| 2. Power Distributor                   | 20C. Thermal Conditioning Panel Heater |
| 3. Environmental Conditioning Duct     | 21. CCS Transponder                    |
| 4. Auxiliary Power Distributor         | 22. CCS Power Amplifier                |
| 5. Measuring Rack A401 or A402         | 23. UHF/RF Transmitter Assembly        |
| 6. TV Junction Box                     | 24. PCM Coaxial Switch                 |
| 7. TV Power Divider                    | 25. CCS Coaxial Switch                 |
| 8. TV Power Amplifier                  | 25A. Thermal Conditioning Panel Heater |
| 9. TV Transmitter Assembly             | 25B. Thermal Conditioning Panel Heater |
| 10. Camera Control Unit (GEC)          | 25C. Thermal Conditioning Panel Heater |
| 11. 56 Volt Power Supply               | 26. Battery D10                        |
| 12. Measuring Rack Selector            | 27. Battery D30                        |
| 13. Source Follower                    | 27A. Water Accumulator Assembly        |
| 14. Electronic Controller Assembly     | 27B. Water Solenoid Valve              |
| 15. Control Accelerometer (Pitch)      | 28. Battery D40                        |
| 15A. Thermal Conditioning Panel Heater | 29. Telemetry Power Divider            |
| 16. S-Band Power Amplifier             | 30. Coaxial Termination                |
| 17. Exciter Units                      | 31. Coaxial Switch                     |
| 18. S-Band Power Amplifier             | 32. Battery D20                        |
| 19. Camera Control Unit (GEC)          | 32A. Thermal Expansion Chamber         |
| 20. Camera Control Unit (Kintel)       | 33. First Stage Pressure Regulator     |
| 20A. Thermal Conditioning Panel Heater |  |

**REFER TO TABLE 1 FOR COMPONENT EFFECTIVITIES**



FIGURE 1 COMPONENT NOMENCLATURE BY CALLOUT NUMBER (Continued)

- |   |   |
|---|---|
| 34. Methanol-Water Accumulator                        | 51. Auxiliary Power Distributor                     |
| 35. Coolant Pump                                      | 52. CP1 or DP1 Multiplexer Assembly                 |
| 36. Water Solenoid Valve                              | 53. Telemetry RF Coupler                            |
| 37. Water Accumulator                                 | 54. F2 RF Transmitter Assembly Model II             |
| 38. Heat Exchanger Assembly                           | 55. VSWR Measuring Assembly Model 220               |
| 39. Modulating Flow Control Valve                     | 56. F2 Telemeter Assembly                           |
| 40. 50-Cubic-Inch Spheres                             | 57. S1 RF Transmitter Assembly Model II             |
| 41. Valve, Shutoff Methanol-Water (Manually Operated) | 58. S1 Telemeter Assembly                           |
| 41A. Umbilical Plate                                  | 59. Remote Digital Multiplexer J                    |
| 42. Hazardous Gas Manifold                            | 60. Telemetry RF Coupler Model 451                  |
| 42A. Access Door                                      | 61. VSWR Measuring Assembly Model 225               |
| 43. Water Solenoid Valve                              | 62. P1 PCM/RF Transmitter Assembly Model II         |
| 44. 165-Cubic-Inch Sphere                             | 63. Telemetry Calibrator Power and Control Assembly |
| 44A. Coolant Pump (Primary)                           | 64. Telemetry Calibrator                            |
| 44B. Coolant Pump (Secondary)                         | 65. Telemetry Directional Coupler Model 226         |
| 44C. Water Solenoid Valve                             |   |
| 45. Slow Speed Multiplexer Assembly                   |   |
| 46. Tape Recorder (Airborne)                          |   |
| 47. Measuring Rack A403                               |   |
| 48. Measuring Distributor                             |   |
| 49. CP1 or DP1 Multiplexer Assembly                   |   |
| 50. Measuring Rack A402 or A405                       |   |

REFER TO TABLE 1 FOR COMPONENT EFFECTIVITIES

FIGURE 1 COMPONENT NOMENCLATURE BY CALLOUT NUMBER (Continued)

66. EDS Distributor	80. Switch Selector
67. Measuring Distributor	81. Remote Digital Submultiplexer
68. Measuring Rack A404	82. Control-EDS Rate Gyros
69. F1 RF Transmitter Assembly	83. Control Signal Processor
70. PCM/DDAS Telemeter Assembly	84. Measuring Rack A404 or A409
71. C-Band Transponder	85. Measuring Rack A403 or A406
72. 5-Volt Measuring Voltage Supply	86. Flight Control Computer
73. F1 Telemeter	87. EDS Timer No. 2 (20 Second Timer)
74. P1 PCM/RF Transmitter Assembly CT-19B	88. EDS Timer No. 1 or 3 (30, 40, or 60 Second Timer)
75. Telemetry Calibrator Power and Control Assembly	89. Command Directional Coupler
76. Telemetry Calibrator	90. Command Power Divider
77. Measuring Rack A408	90A. Measuring Rack A403 or A406
78. Measuring Rack A407	90B. Control-EDS Rate Gyros
78A. Measuring Rack A406	90C. Thermal Conditioning Panel Heater
79. P1 PCM/RF Transmitter Assembly Model II	90D. Thermal Conditioning Panel Heater
	90E. CCS Power Divider

REFER TO TABLE 1 FOR COMPONENT EFFECTIVITIES

**FIGURE 1 COMPONENT NOMENCLATURE BY CALLOUT NUMBER (Continued)**

- |  |   |
|--|---|
| 91. Remote Digital Multiplexer J         | 111. Gas Bearing Heat Exchanger                                 |
| 92. DDAS/Computer Interface Unit         | 112. Control Accelerometer (Yaw)                                |
| 93. CCS Hybrid Ring                      | 113. Force Balance Accelerometers                               |
| 94. CCS Power Divider                    | 114. ST-124M Inertial Platform Assembly                         |
| 95. ST-124M Platform Electronic Assembly | 115. Gas Bearing Pressure Regulator                             |
| 96. Launch Vehicle Data Adapter          | 116. Low Pressure Switch  |
| 97. Control Distributor                  | 117. Two-Cubic-Foot Sphere                                      |
| 98. Command Receiver                     | 118. Gas Bearing Solenoid Valve                                 |
| 99. Secure Range Safety Decoder          | 119. Lateral Accelerometer Slosh, Pitch, and Yaw                |
| 100. Remote Digital Multiplexer K        | 120. Longitudinal Accelerometer Orbital LH <sub>2</sub> Venting |
| 101. Launch Vehicle Digital Computer     | 121. Gas Bearing Heat Exchanger                                 |
| 102. Plug Type J-Box Assembly            | 122. Measuring Rack A669  |
| 103. ST-124M Platform AC Power Supply    | 123. UHF/RF Filter  |
| 104. Accelerometer Signal Conditioner    | 123A. Gas Bearing Heat Exchanger                                |
| 105. Command Decoder                     | 123B. Thermal Conditioning Panel Heater                         |
| 106. Remote Digital Multiplexer K        | 124. Gas Bearing Heat Exchanger                                 |
| 107. Command Decoder                     | 125. Gas Bearing Solenoid Valve                                 |
| 108. C-Band Transponder                  |   |
| 109. Azusa RI Filter Assembly            |   |
| 110. Azusa Transponder                   |   |

**REFER TO TABLE 1 FOR COMPONENT EFFECTIVITIES**

Figure 1. Instrument Unit Component Locations (Sheet 1 of 19)

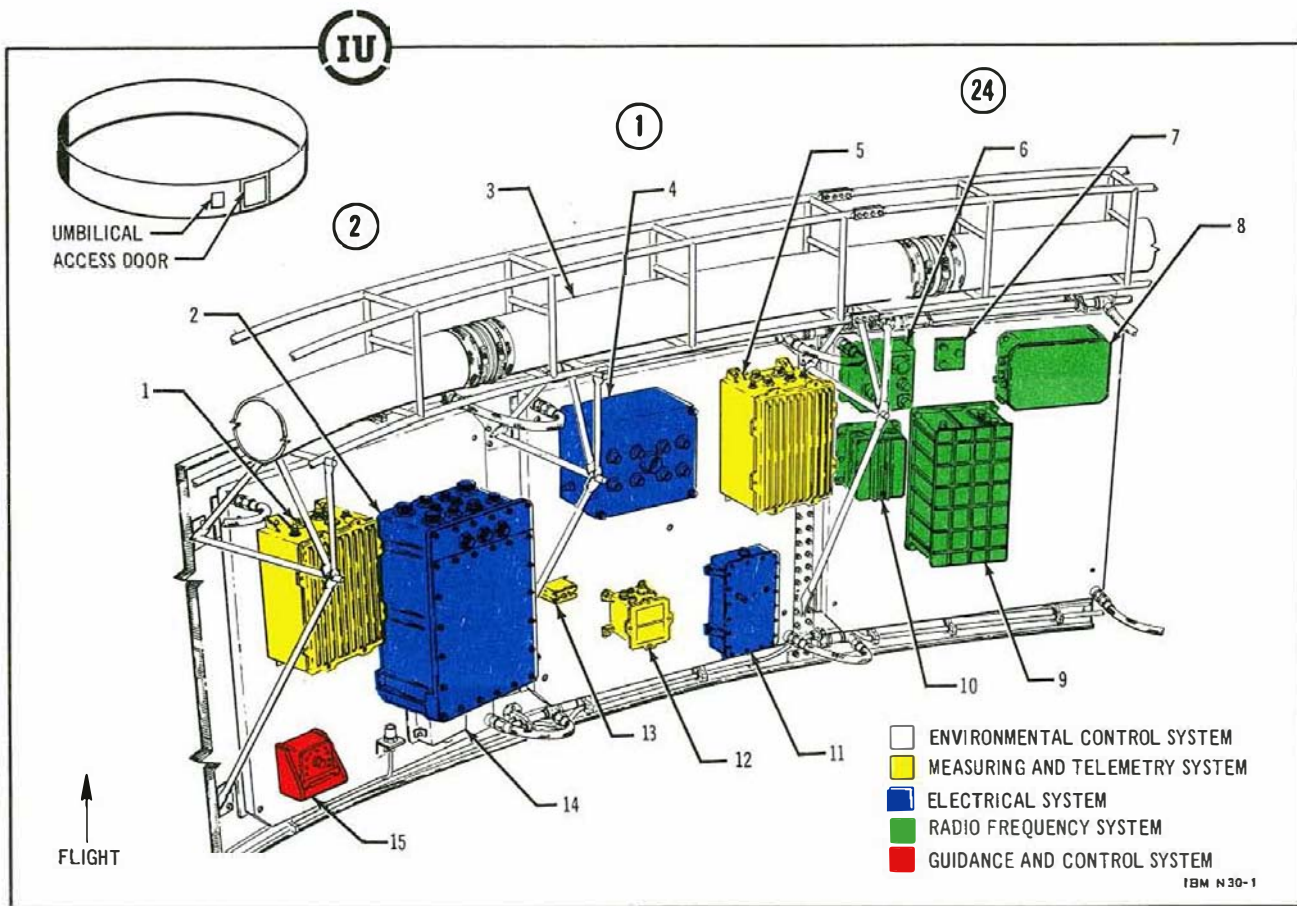

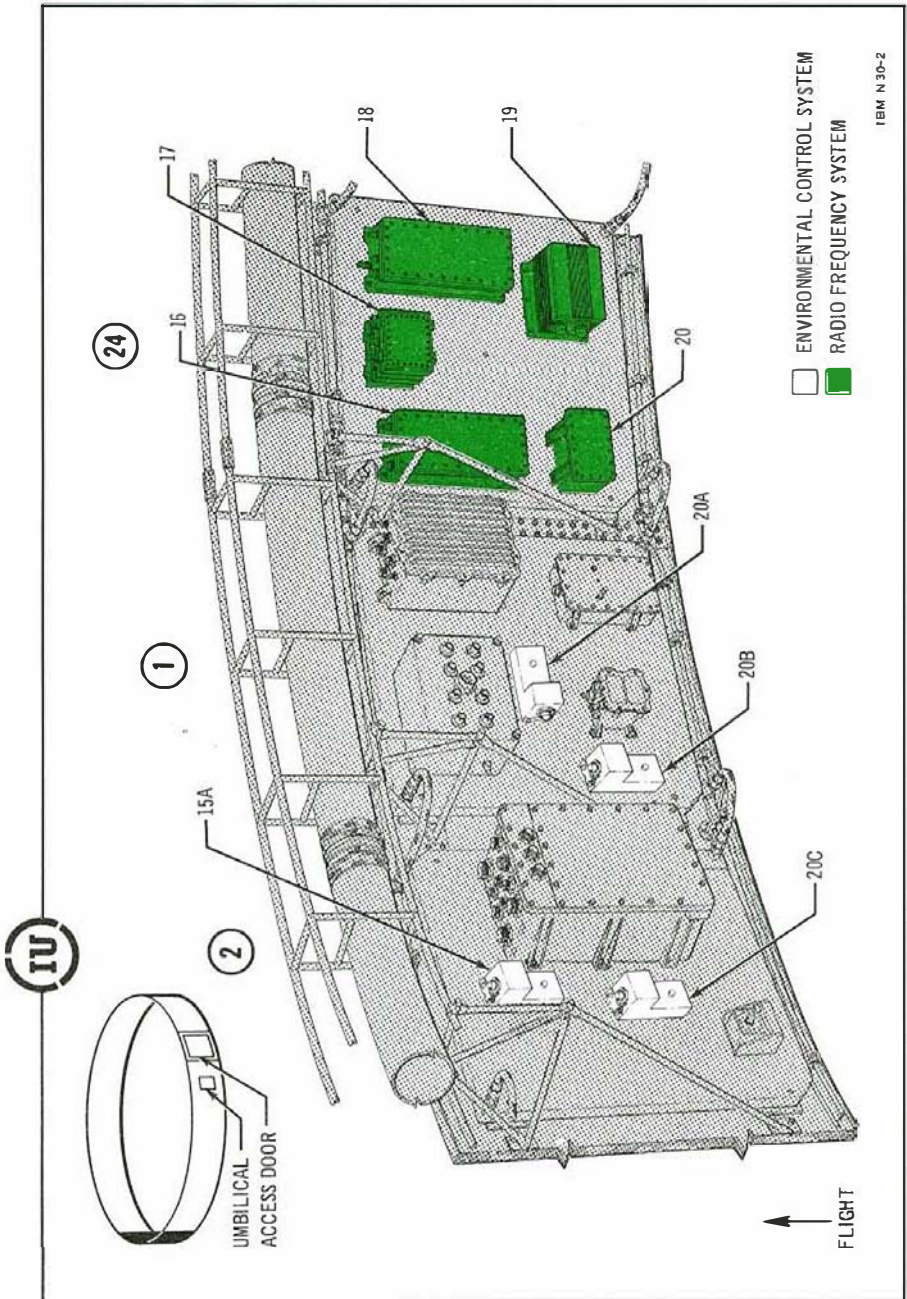
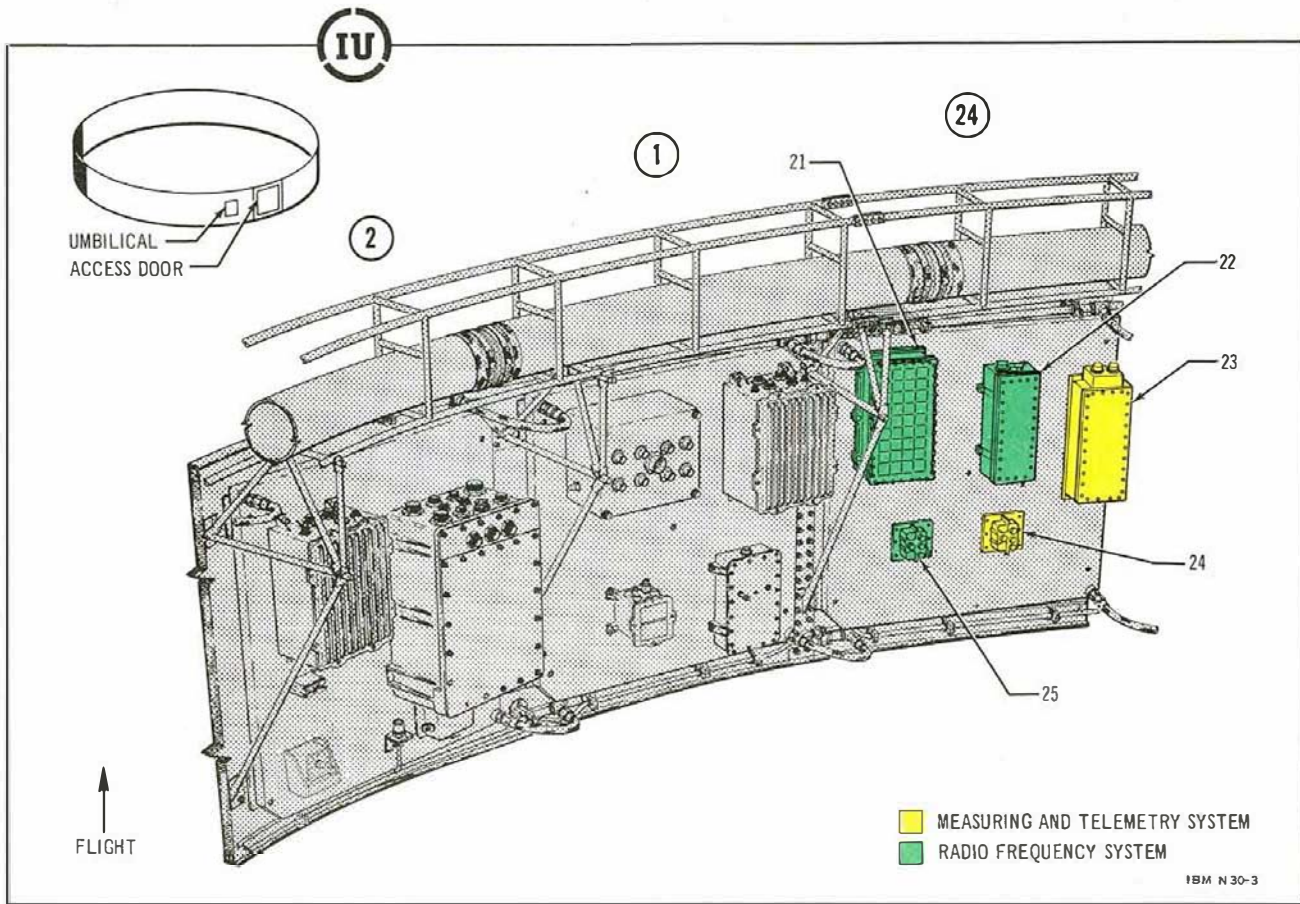

Figure 1. Instrument Unit Component Locations (sheet 2 of 19)

Figure 1. Instrument Unit Component Locations (sheet 3 of 19)



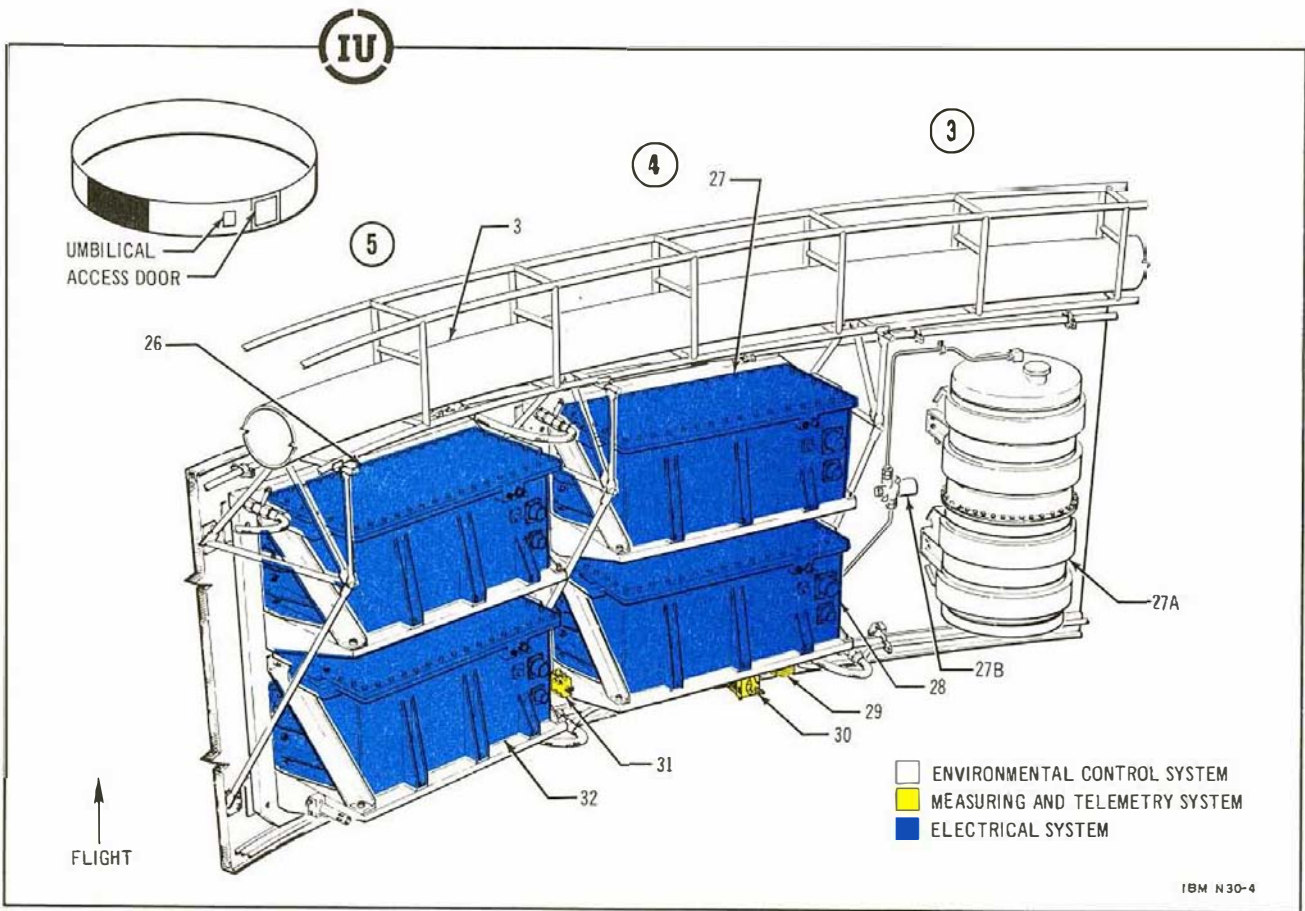
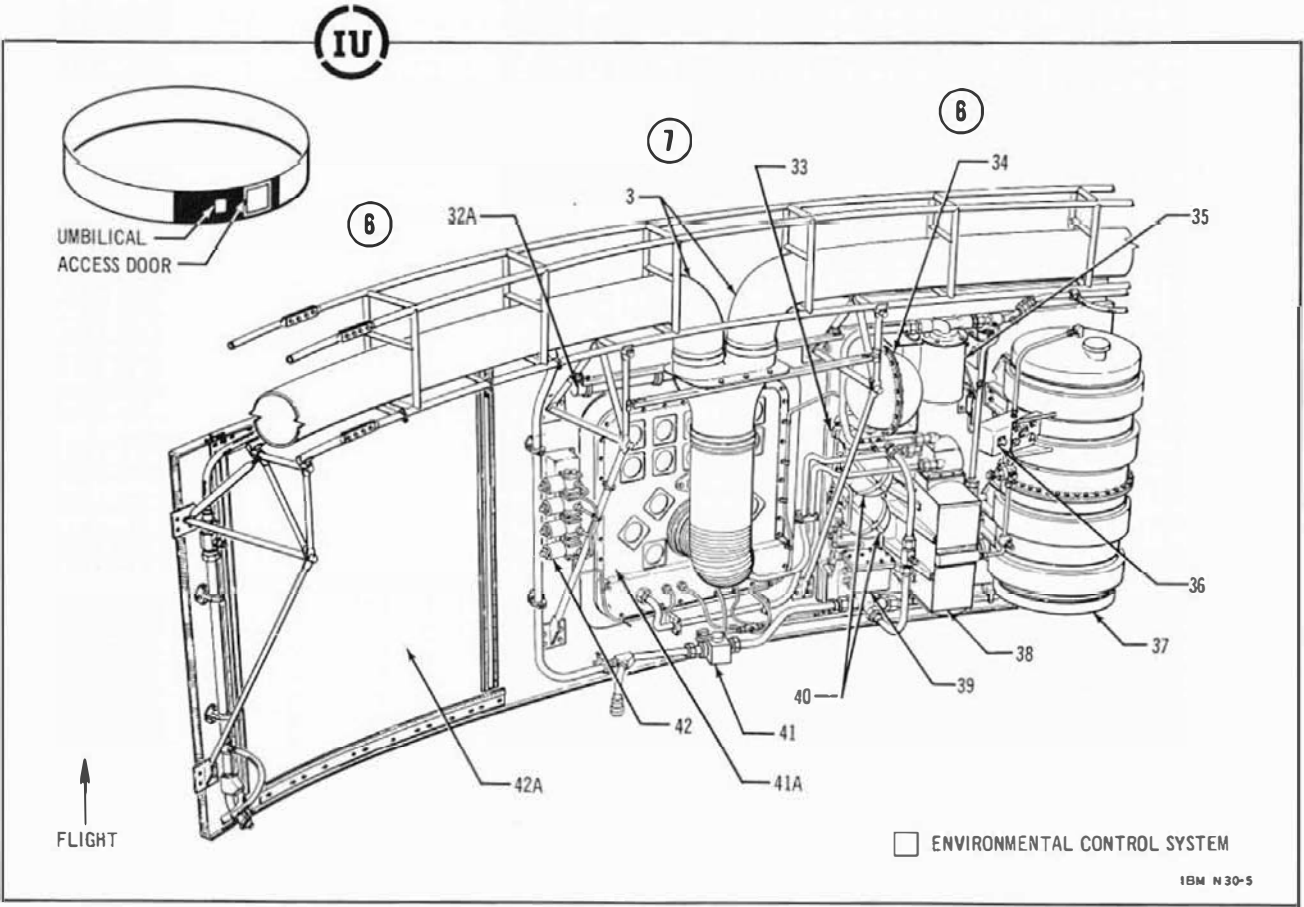

Figure 1. Instrument Unit Component Locations (sheet 4 of 19)

Figure 1. Instrument Unit Component Locations (sheet 5 of 19)





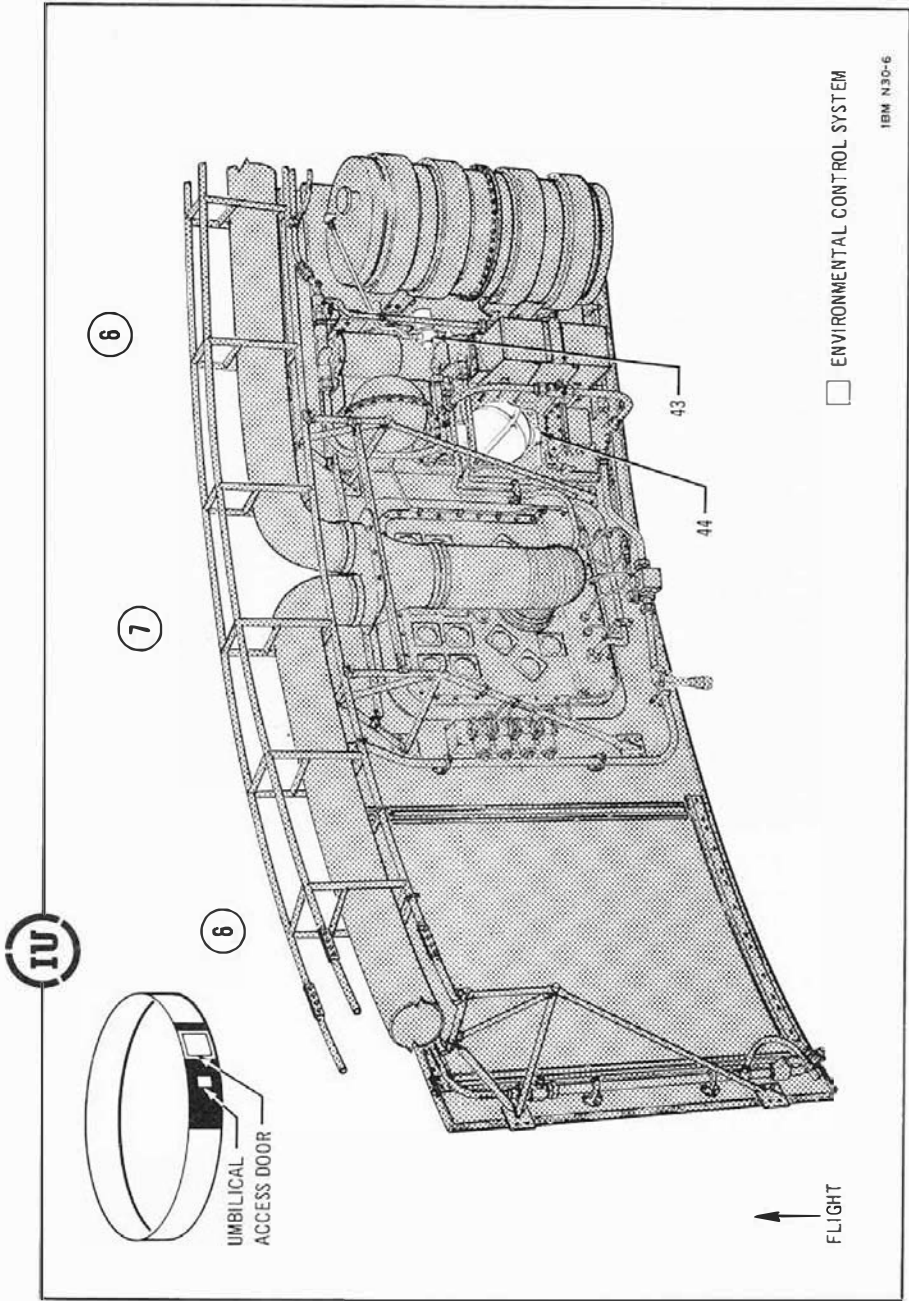

Figure 1. Instrument Unit Component Locations (sheet 6 of 19)

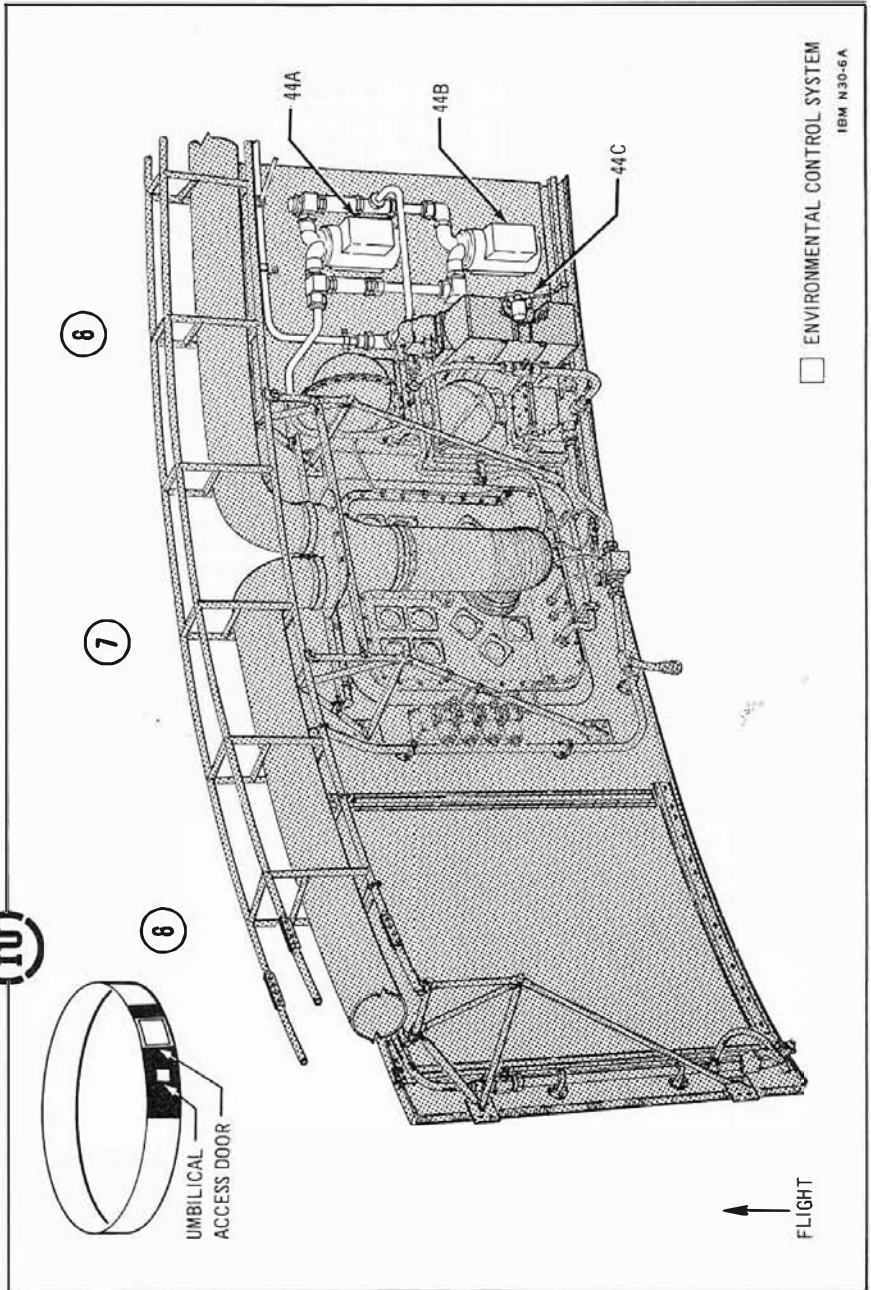
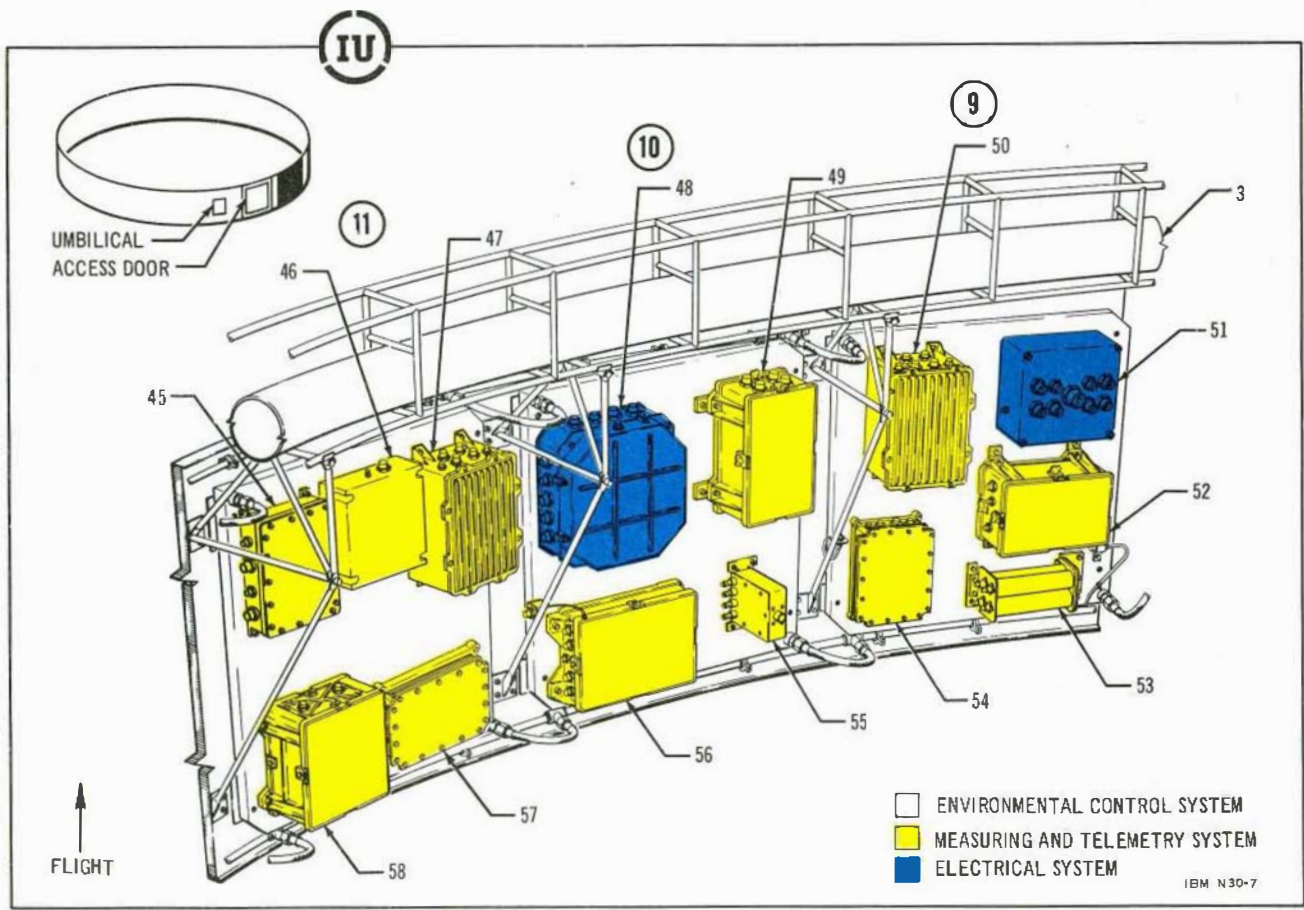

Figure 1. Instrument Unit Component Locations (sheet 6A of 19)

Figure 1. Instrument Unit Component Locations (sheet 7 of 19)



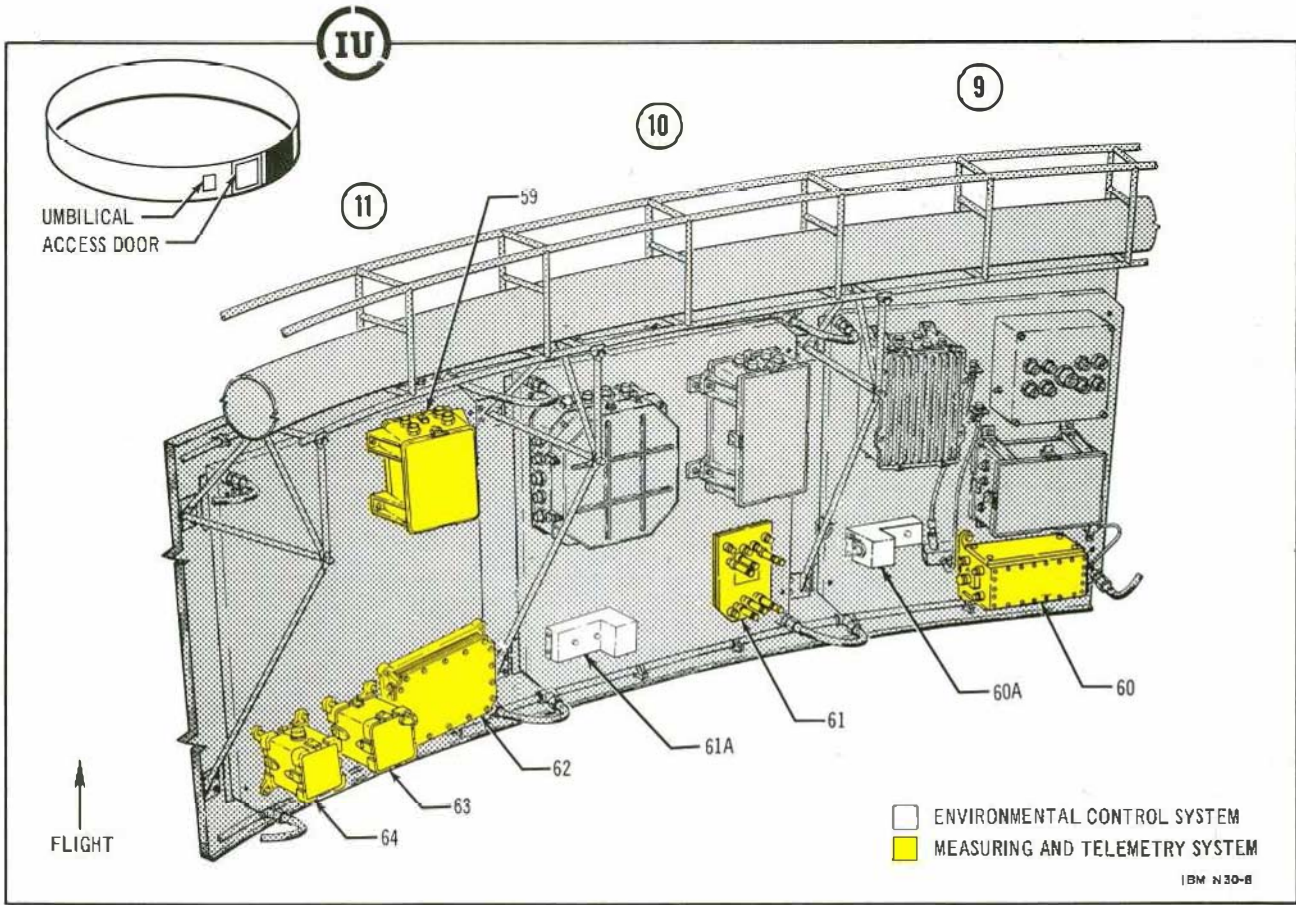
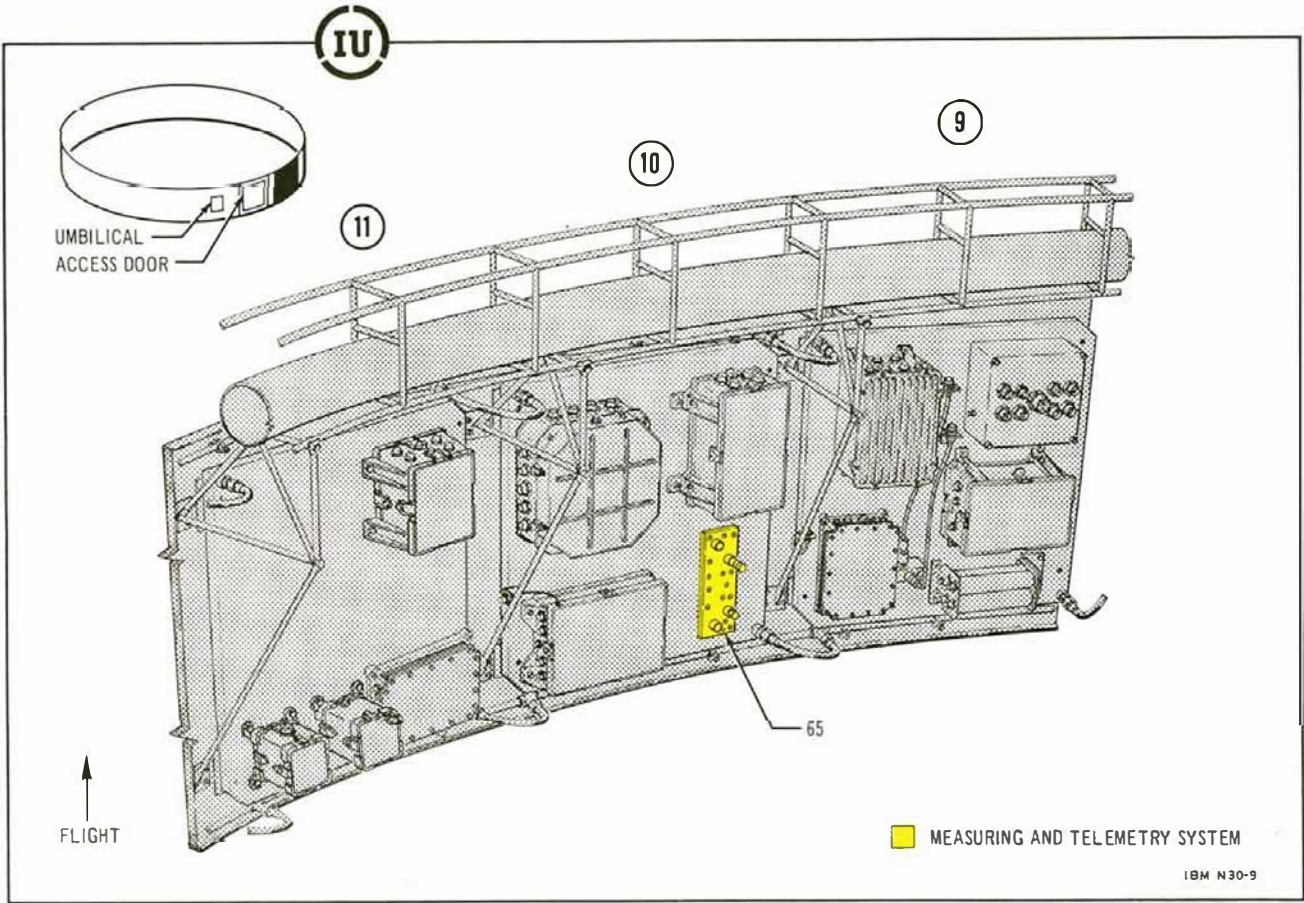
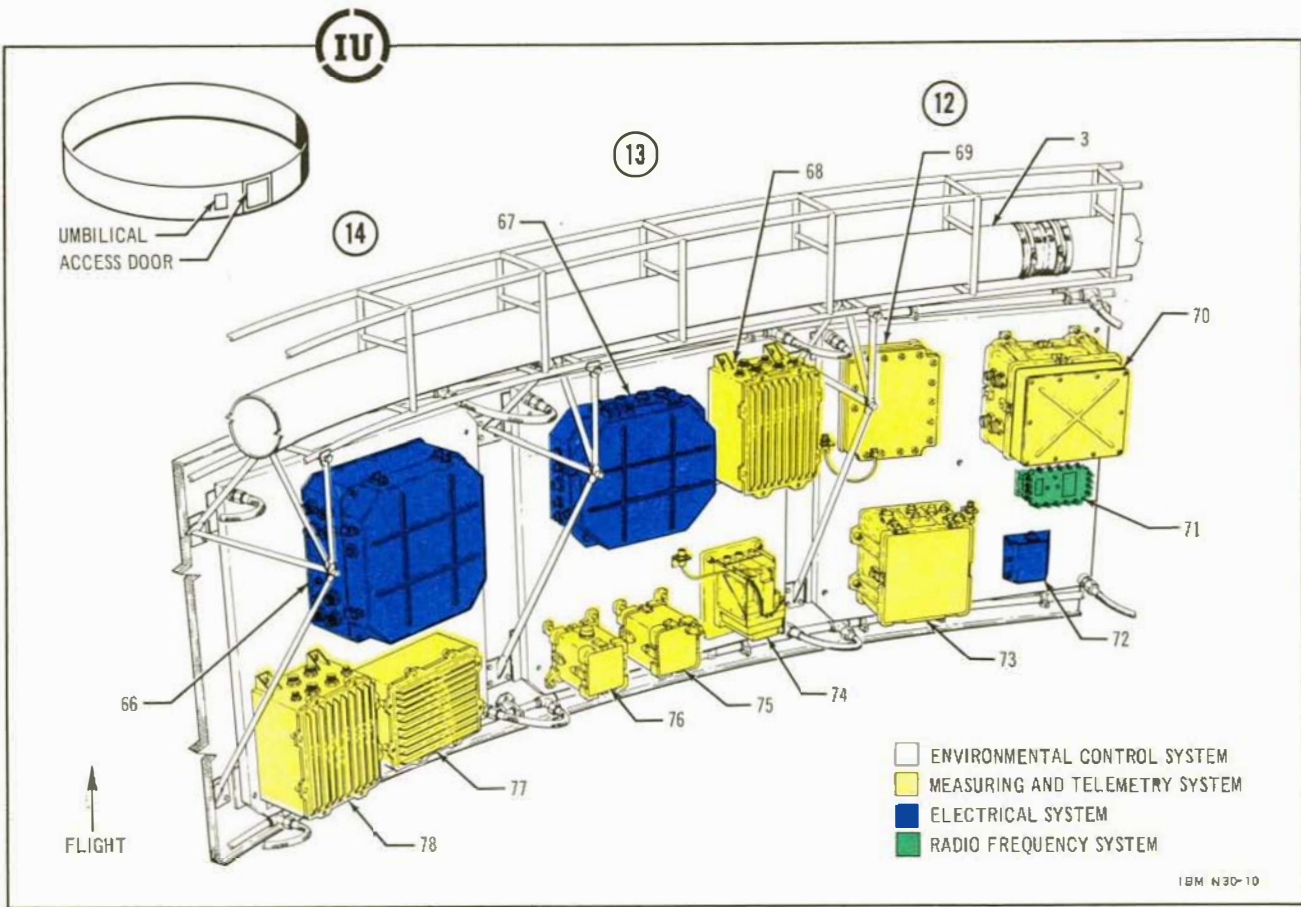

Figure 1. Instrument Unit Component Locations (sheet 8 of 19)

Figure 1. Instrument Unit Component Locations (Sheet 9 of 19)





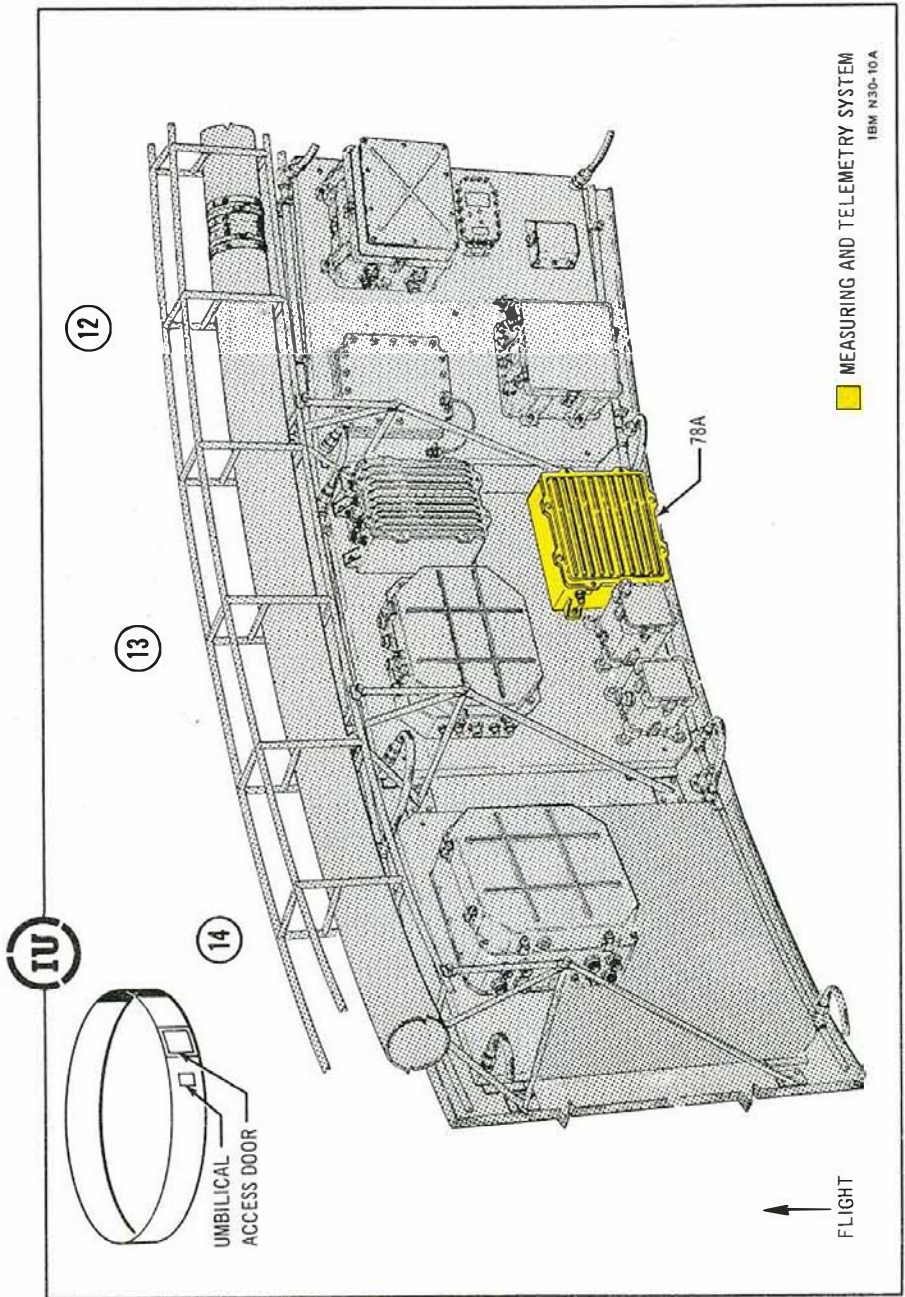
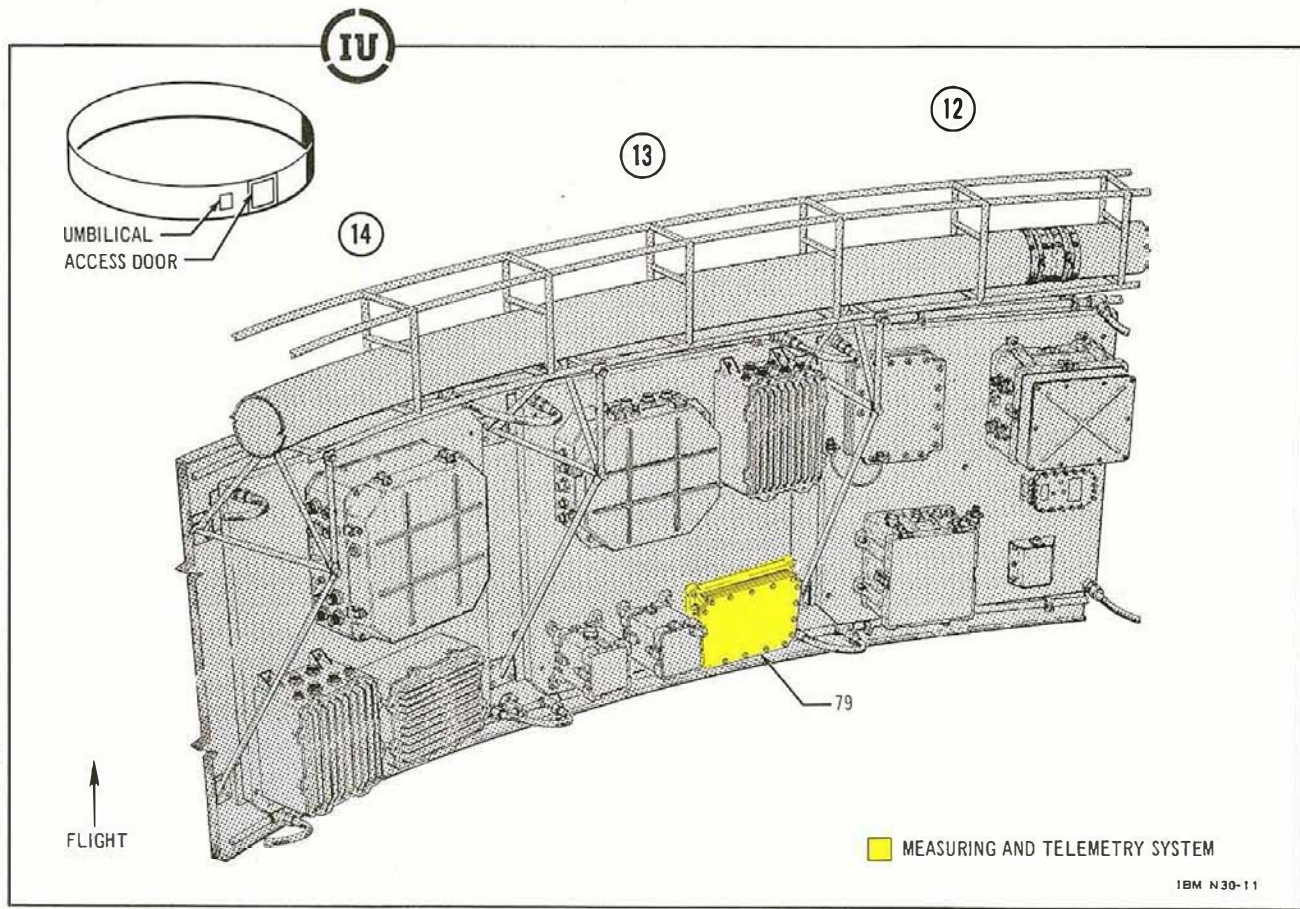

Figure 1. Instrument Unit Component Locations (sheet 10A of 19)

Figure 1. Instrument Unit Component Locations (Sheet 11 of 19)





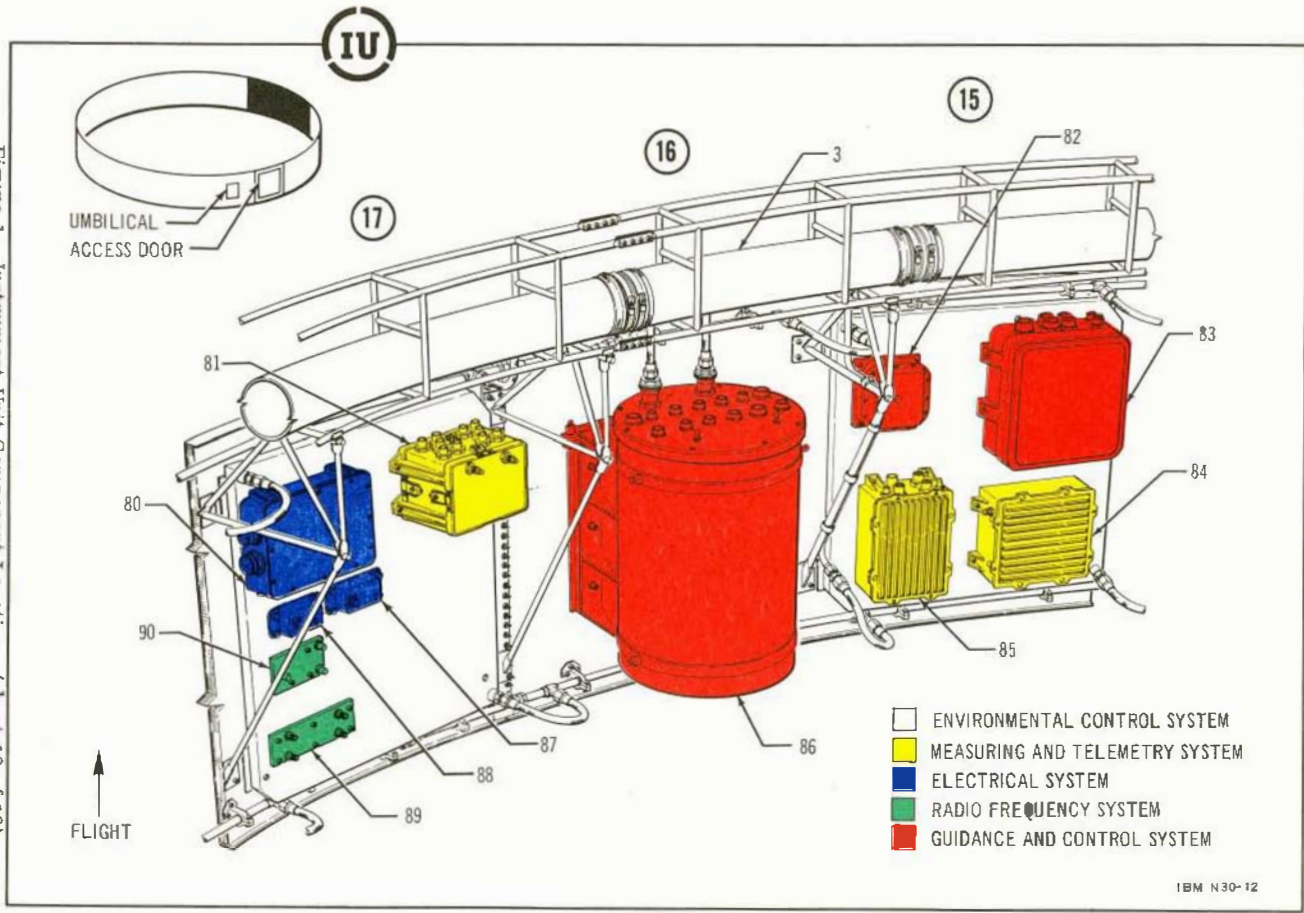

Figure 1. Instrument Unit Component Locations (Sheet 12 of 19)

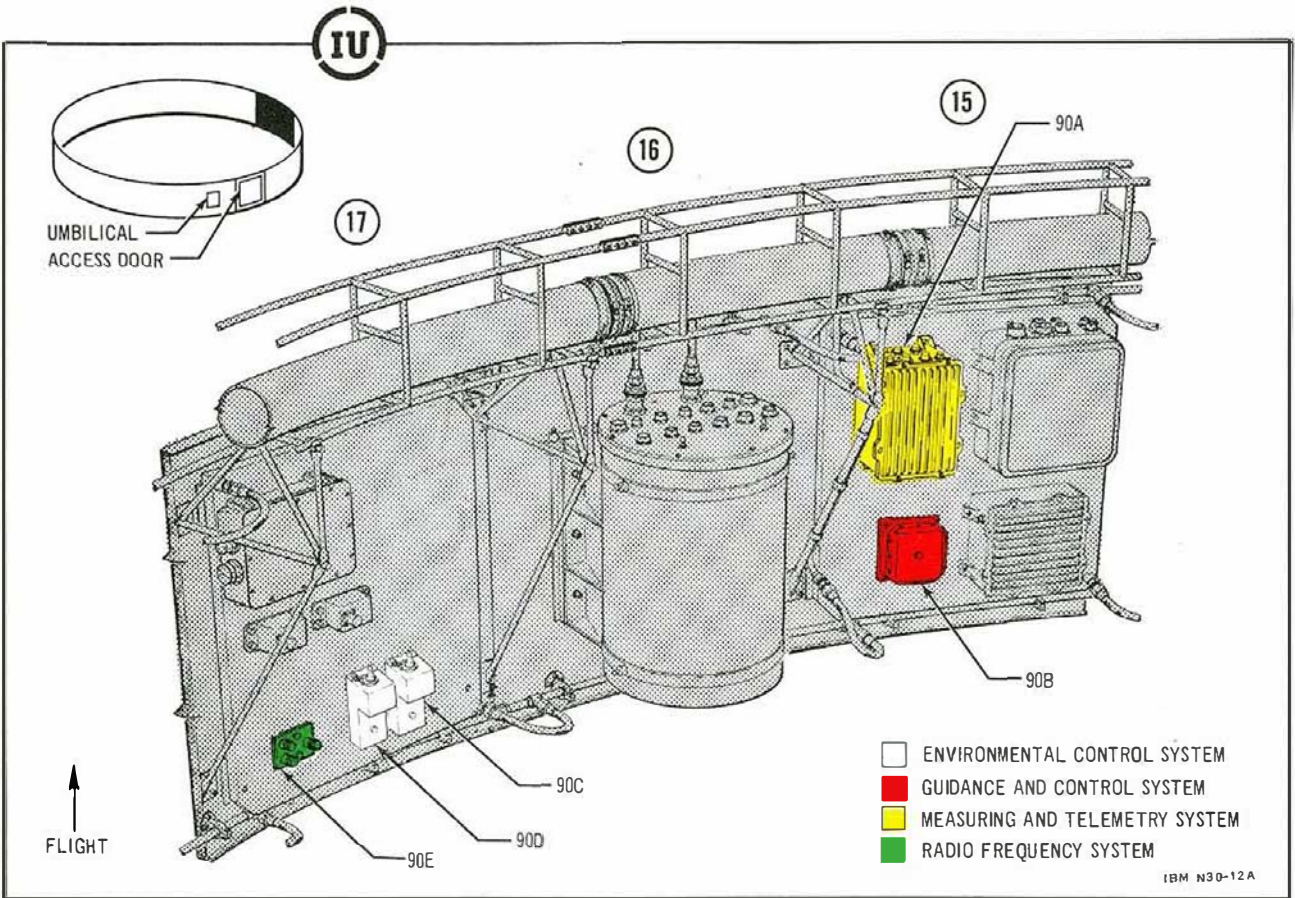
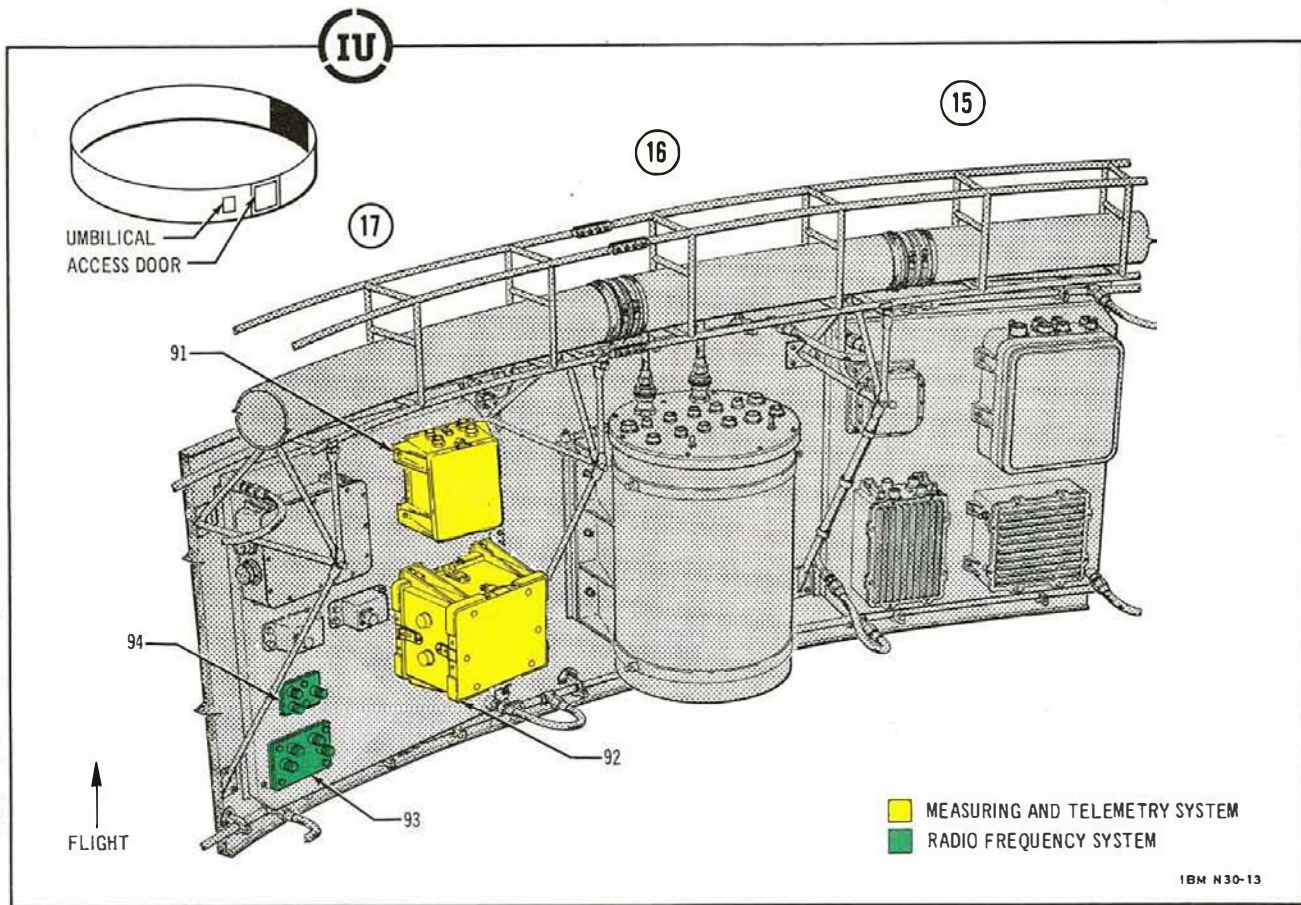
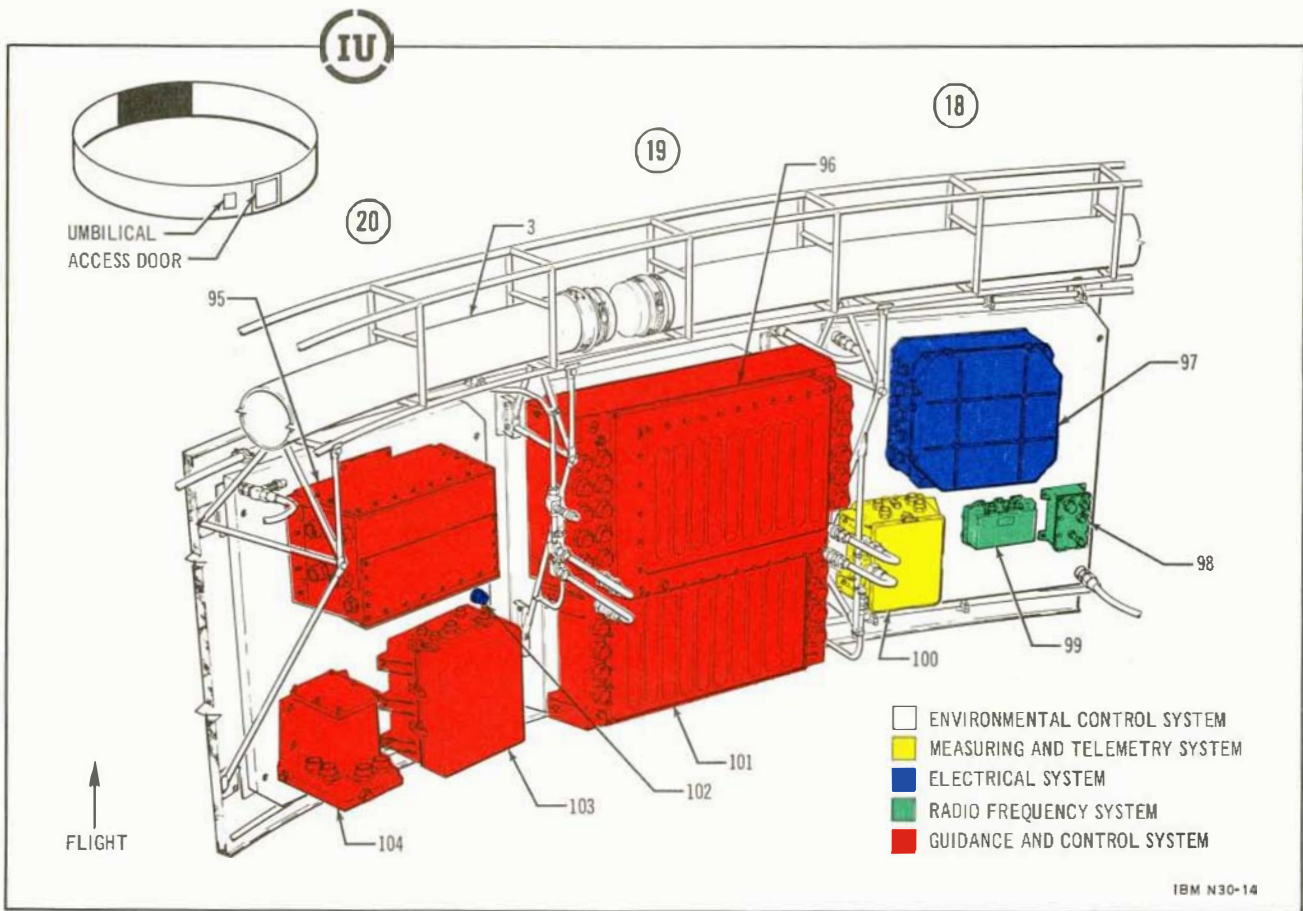

Figure 1. Instrument Unit Component Locations (sheet 13 of 19)





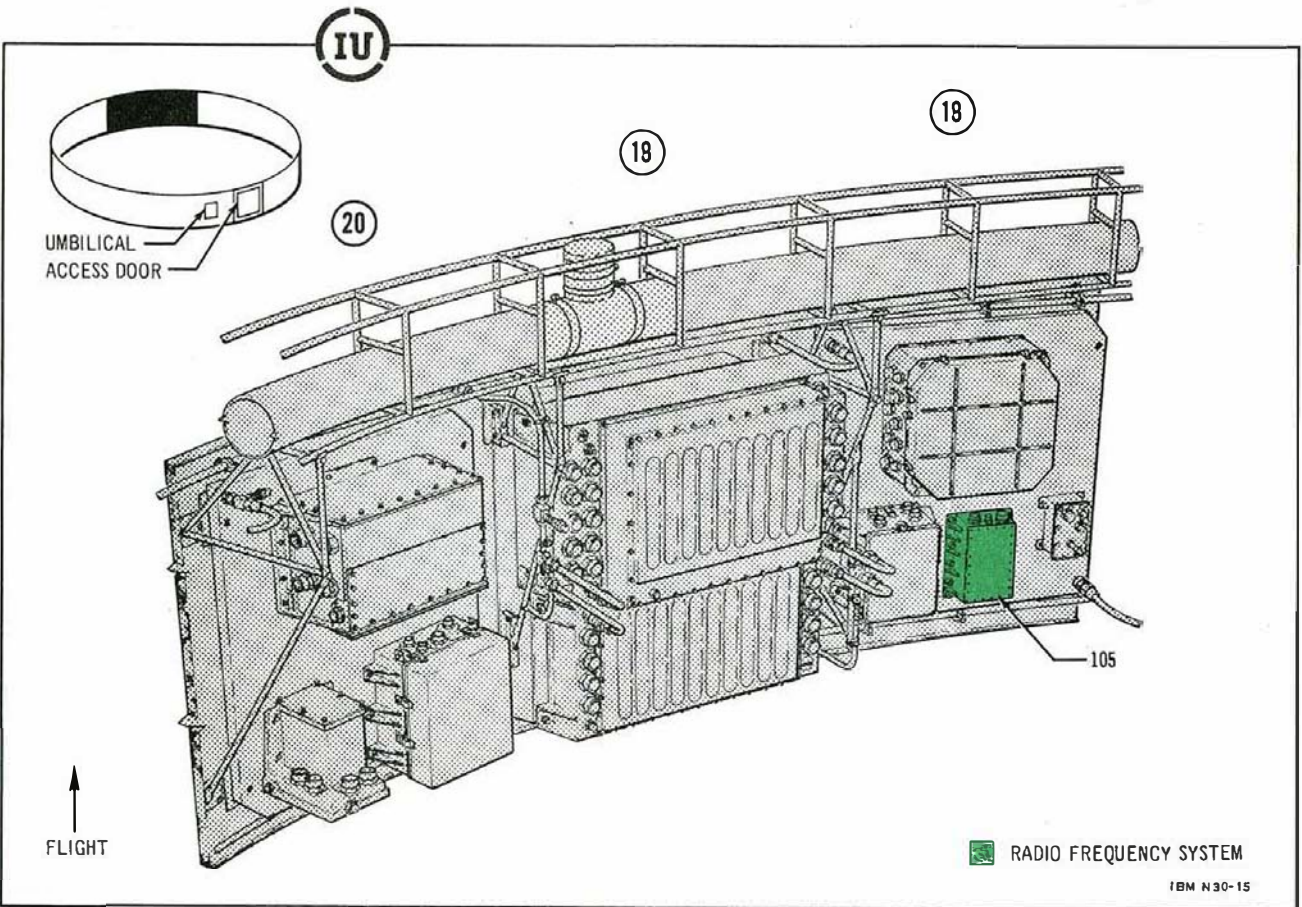
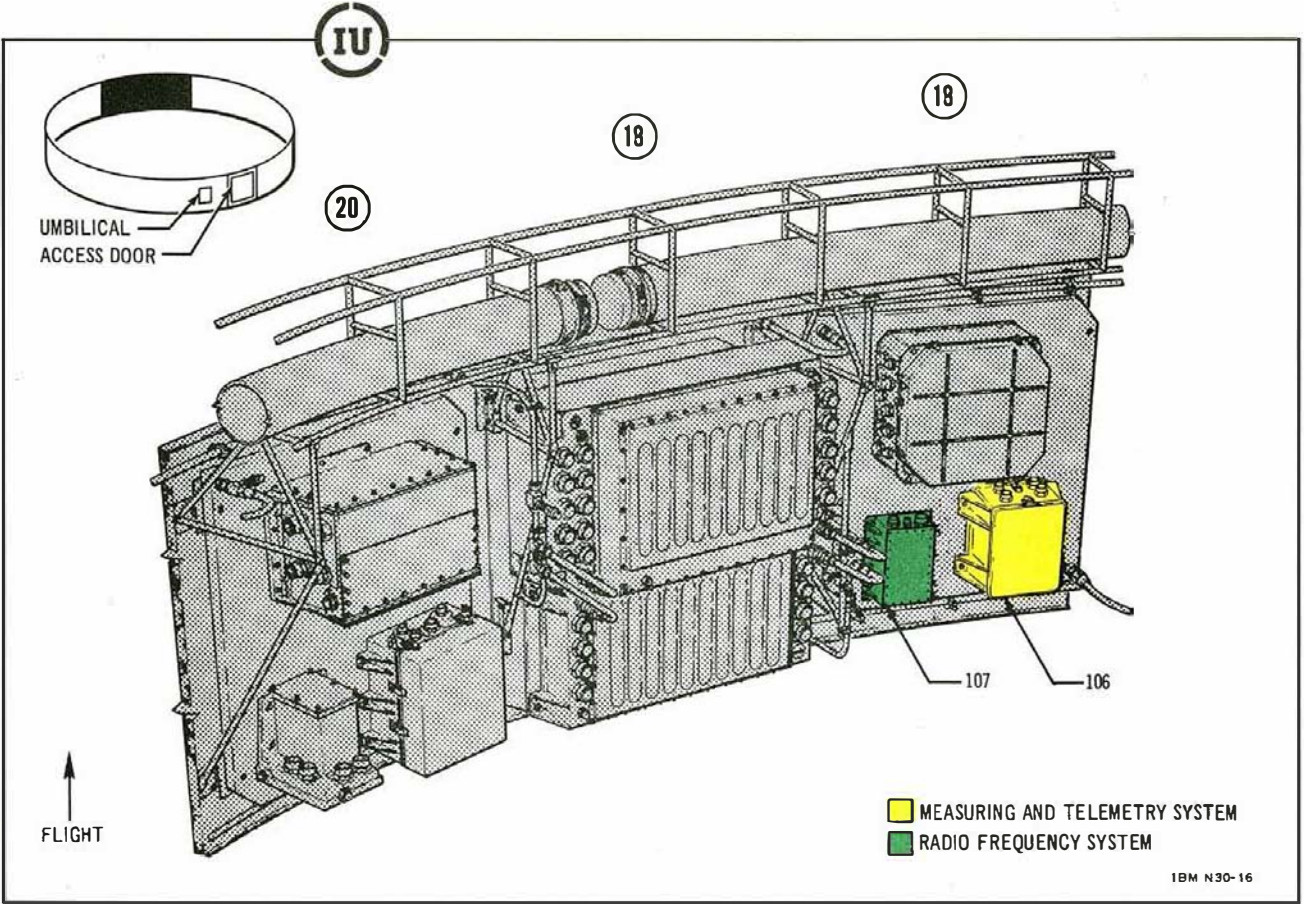

Figure 1. Instrument Unit Component Locations (sheet 15 of 19)



IBM N30-16

Figure 1. Instrument Unit Component Locations (sheet 16 of 19)

IU

Figure 1. Instrument Unit Component Locations (sheet 17 of 19)

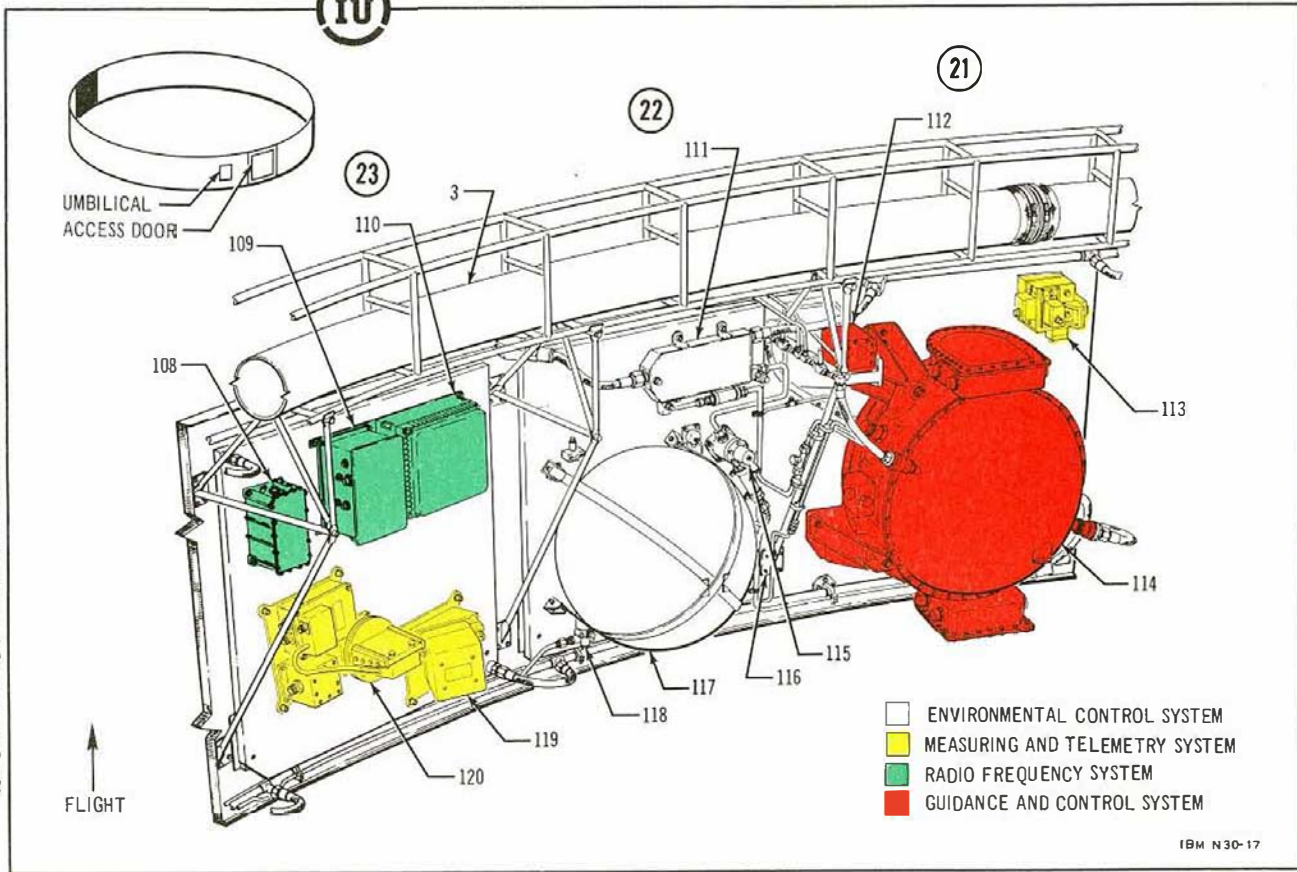

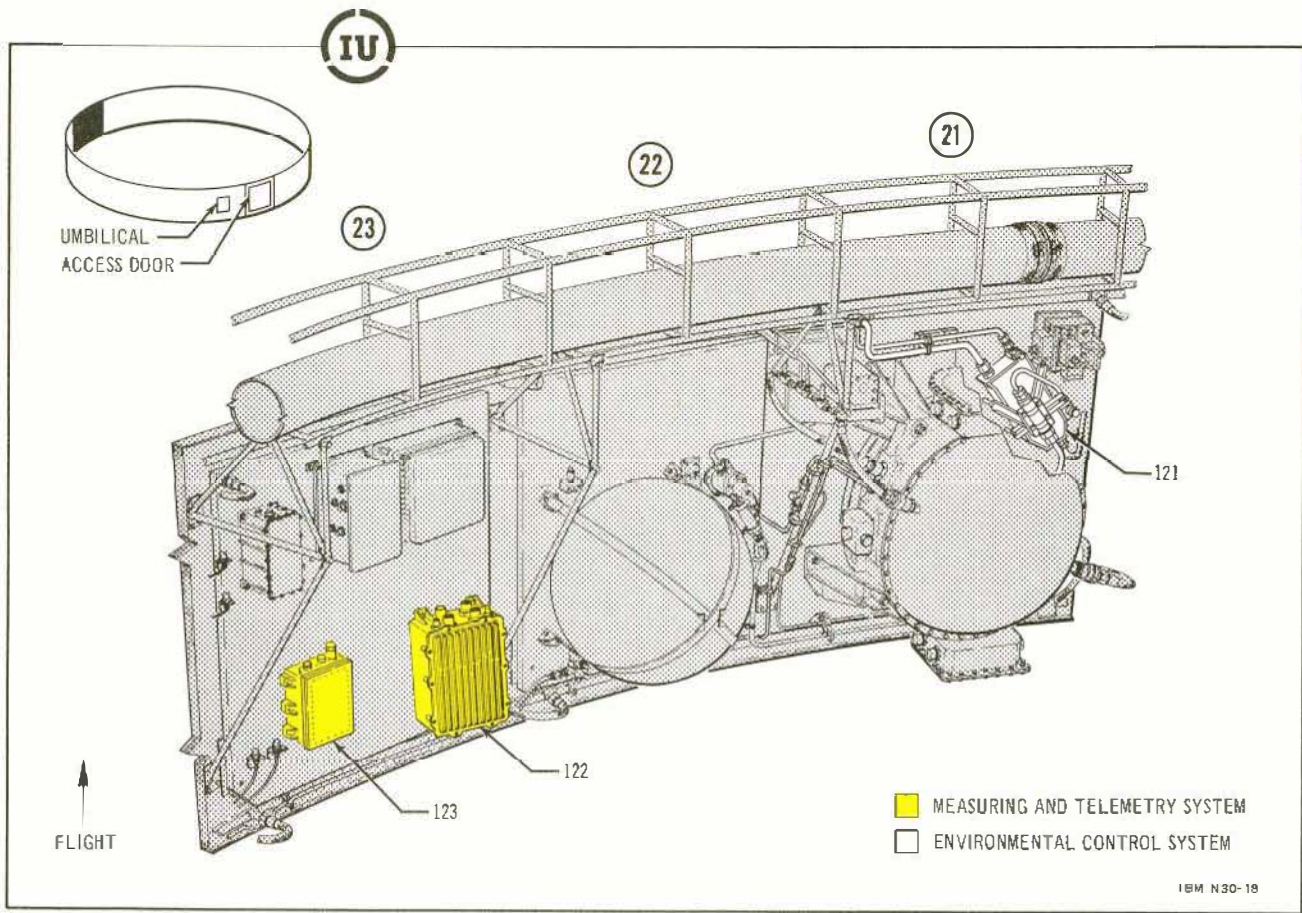

Figure 1. Instrument Unit Component Locations (sheet 18 of 19)



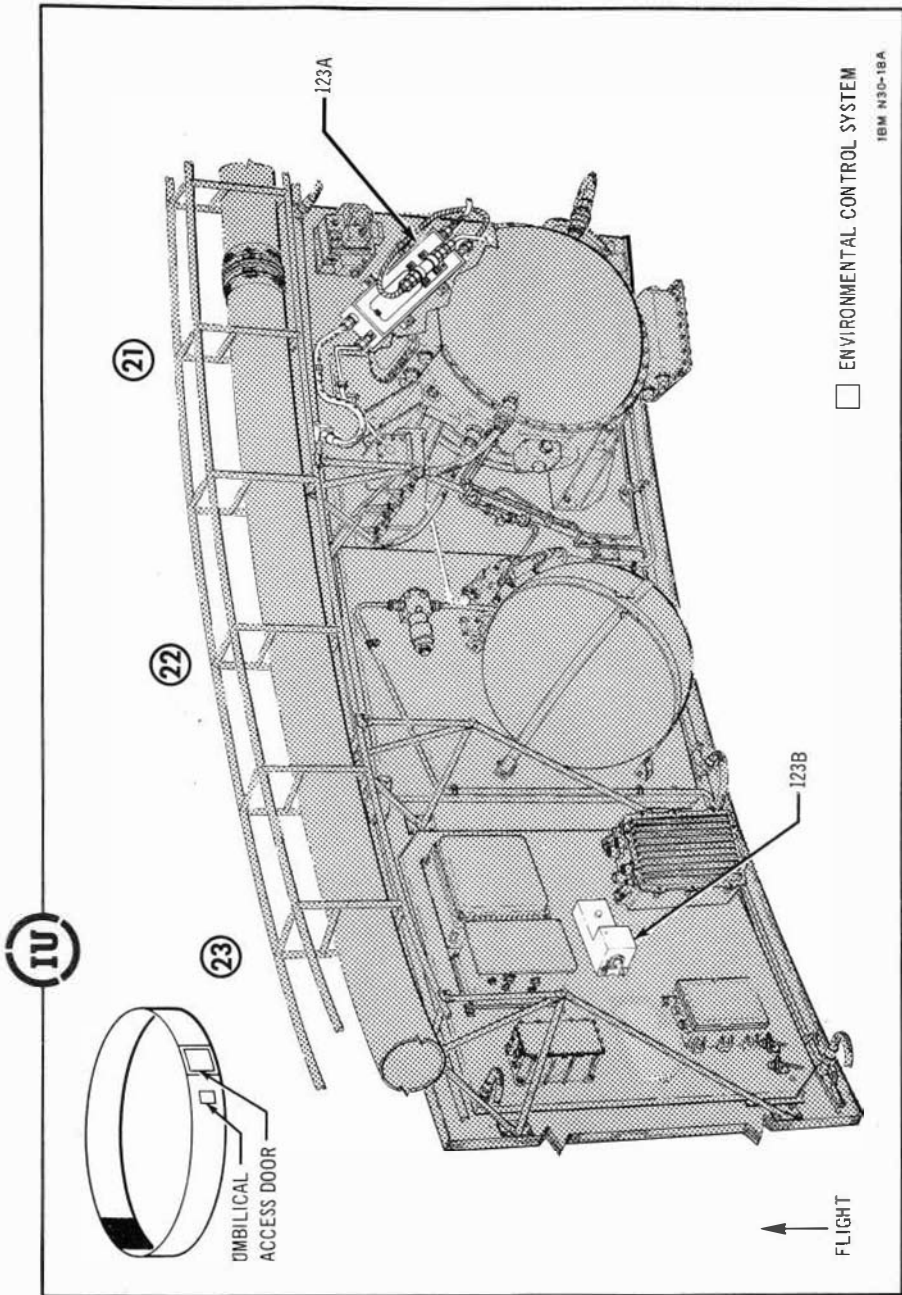

Figure 1. Instrument Unit Component Locations (sheet 18A of 19)

**IV**



UMBILICAL  
ACCESS DOOR

↑  
FLIGHT

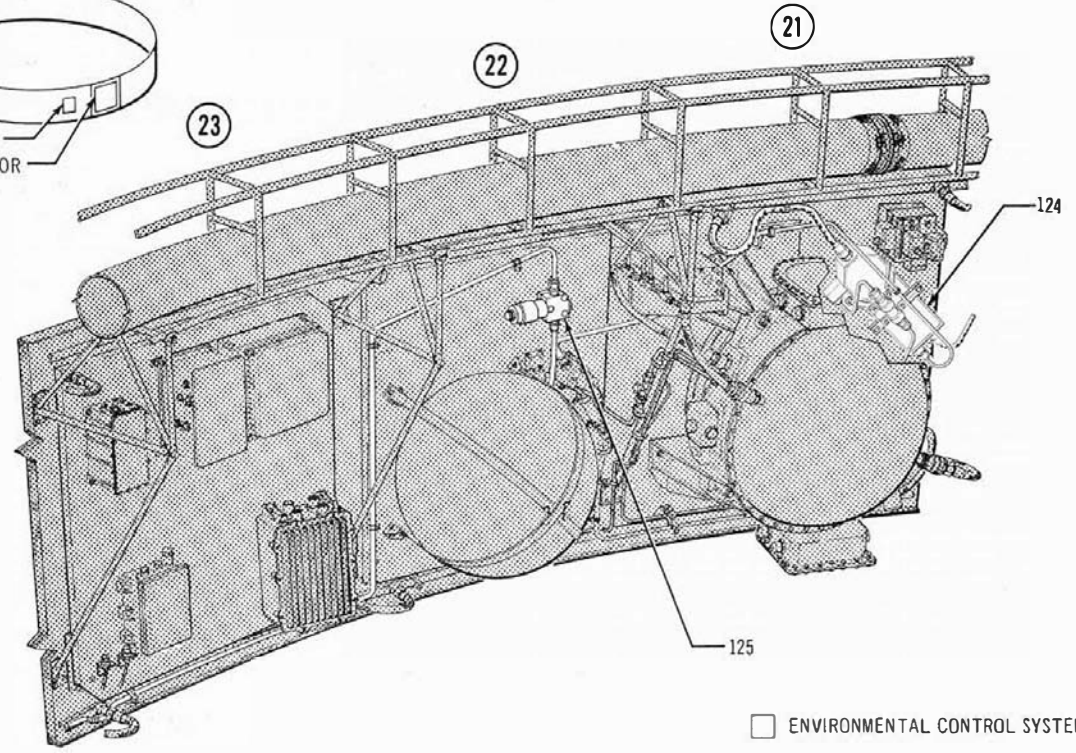

□ ENVIRONMENTAL CONTROL SYSTEM

IBM N30-19

Figure 1. Instrument Unit Component Locations (sheet 19 of 19)

Figure 2. Instrument Unit Antenna Locations and Photographs (Sheet 1 of 3)

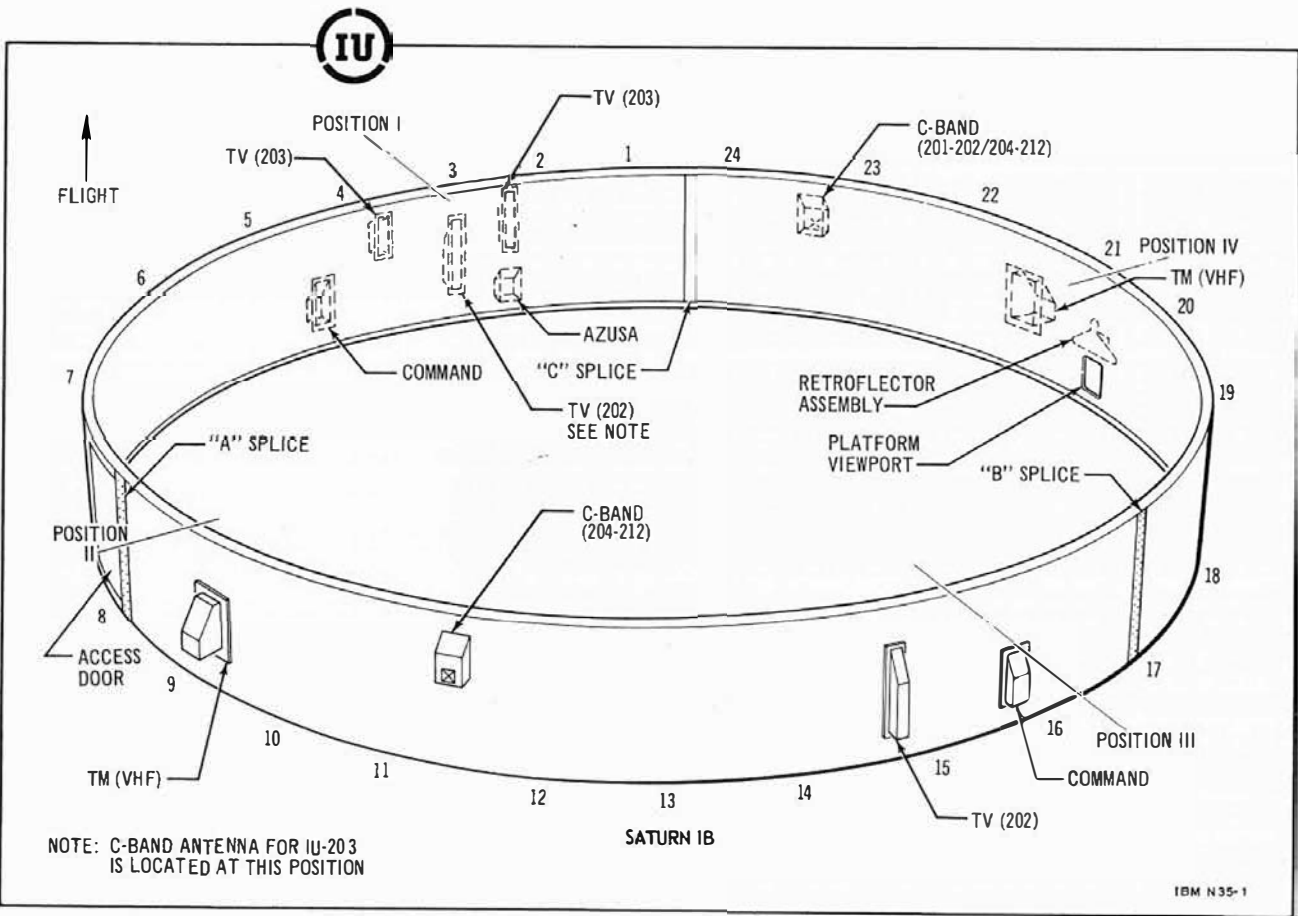
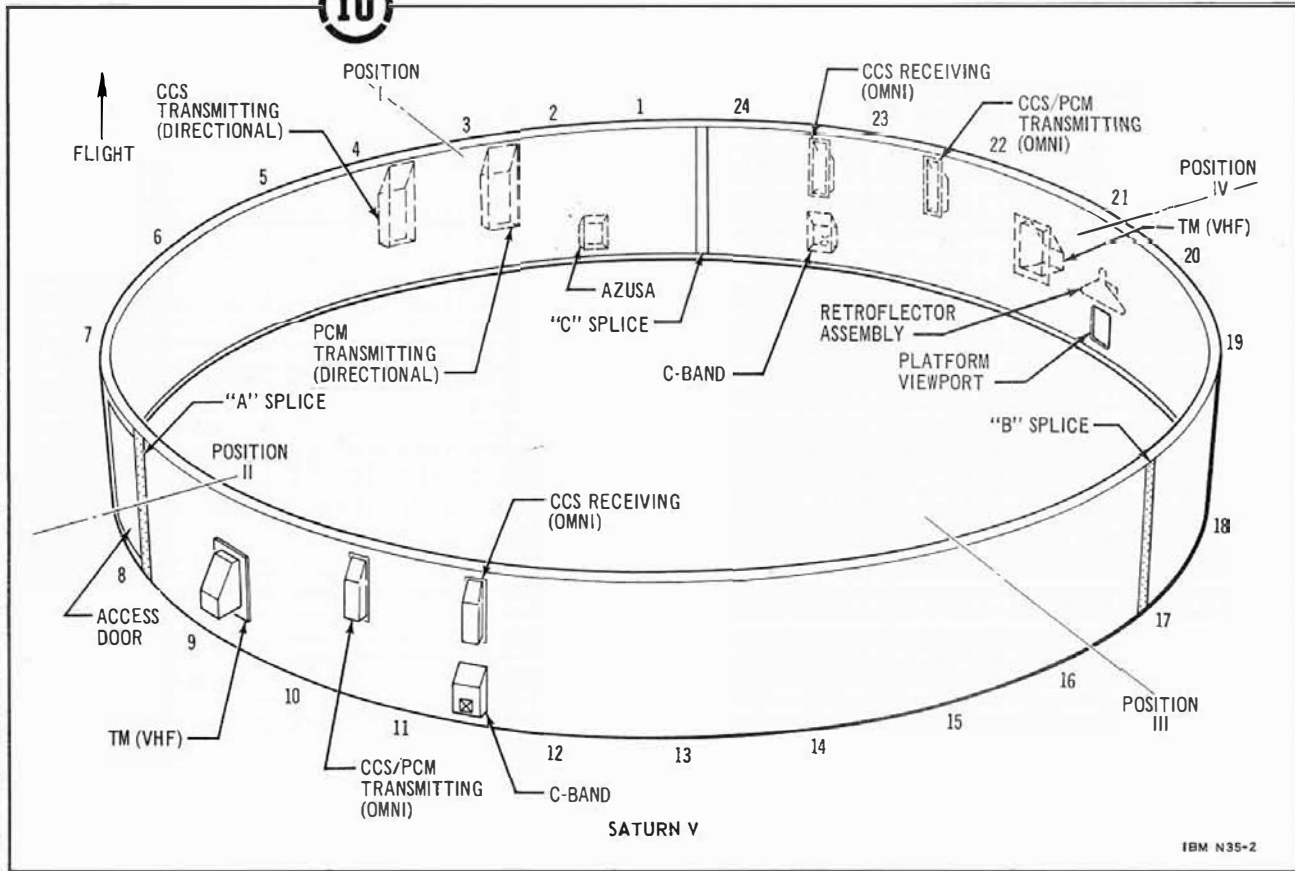
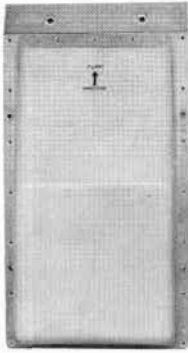



Figure 2. Instrument Unit Antenna Locations and Photographs (Sheet 2 of 3)





COMMAND



AZUSA

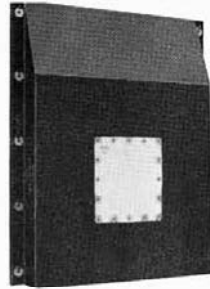

C-BAND



CCS RECEIVING (OMNI)  
CCS/PCM TRANSMITTING (OMNI)  
TV ANTENNA (203)

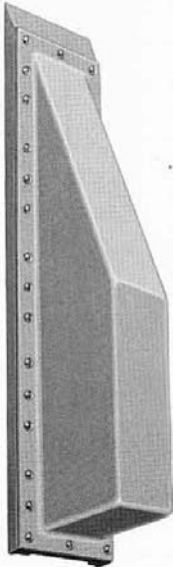

TV ANTENNA  
(202)

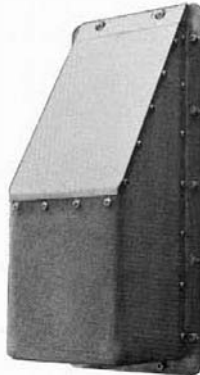

TELEMETRY  
(VHF)



CCS OR PCM  
TRANSMITTING (DIRECTIONAL)

IBM N35-3

Figure 2. Instrument Unit Antenna Locations and Photographs (sheet 3 of 3)



## STRUCTURAL SYSTEM

The Structural System provides mounting support for approximately 3500 pounds of Instrument Unit (IU) components and is, in addition, a load carrying structural element of the complete vehicle. The thrust generated during first-stage burn is transmitted to the payload through the IU structure. The required strength to withstand the resulting forces of weight, thrust, and vehicle maneuvers is achieved at a minimum weight penalty by using an aluminum alloy honeycomb inner core bonded to inner and outer skins of sheet aluminum. The completed IU structure is a 260-inch diameter ring which weighs approximately 450 pounds and is composed of three 120-degree segments. Each segment is approximately 1 inch thick and 36 inches high.

It was apparent that a solid metal structure able to meet the design requirements would be far too heavy. Thus a laminated construction using an aluminum alloy honeycomb sandwich was chosen as a basic structural material. A honeycomb structure may be 90 percent air and yet have strength many times that of a solid panel of equal weight. Honeycomb provides acoustical insulation, low thermal conductivity, and is not as subject to distortion with temperature changes. A honeycomb sandwich is made by bonding a 0.030-inch outer and a 0.020-inch inner surface sheet to the honeycomb core. The completed sandwich is 0.95 inch thick.

Assembly of the IU structure requires many steps; some of these steps are illustrated on the following pages. The segments are mounted on special tools to accurately align them for splicing. Holes are drilled at the segment junctions, and fasteners are installed with potting compound. Splice plates are clamped to the segments and back-drilled to match the fastener locations. The splice joints are then micro-finished to insure that the splice plates will be fitted to a smooth surface. Then the splice plates are bolted to the segments, completing the splices. Protective rings are temporarily installed on the fore and aft edges to allow the IU to be moved without endangering the structure. A cable tray formed of aluminum alloy tubing is mounted around the inside and above the structure. The structure is then ready to receive the components that are mounted in the IU.

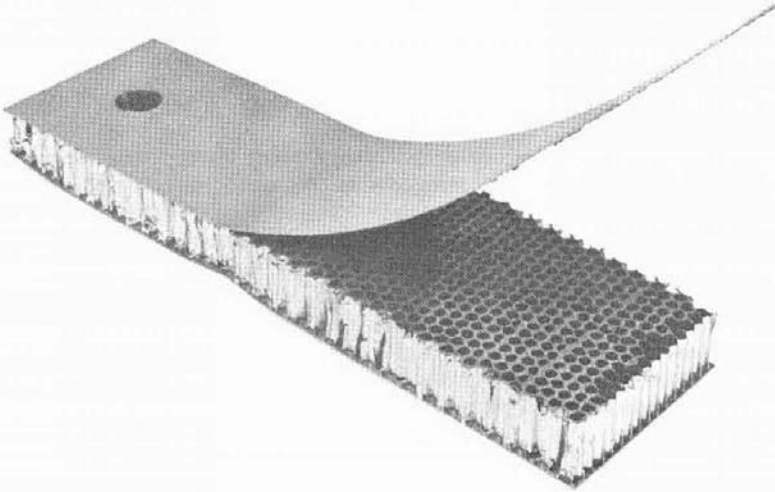

1. LAMINATED HONEYCOMB SANDWICH MATERIAL

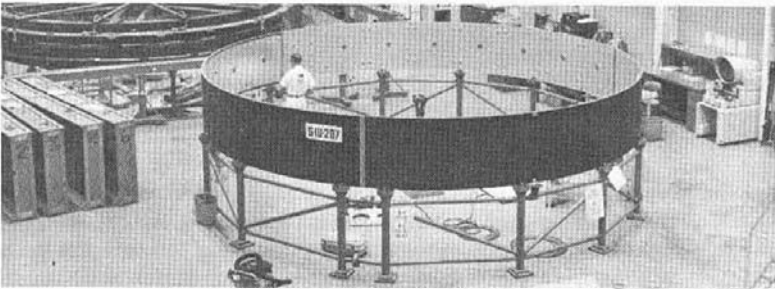

2. SEGMENTS ALIGNED FOR SPLICING

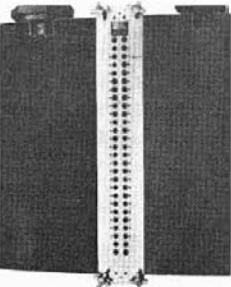

3. DRILL JIG INSTALLED AT SPLICE JOINT



4. MICRO-FINISHING SPLICE JOINT

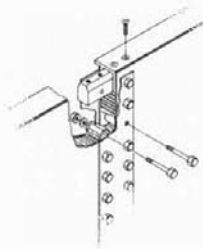

5. COMPLETED SPLICE

IBM N116-1



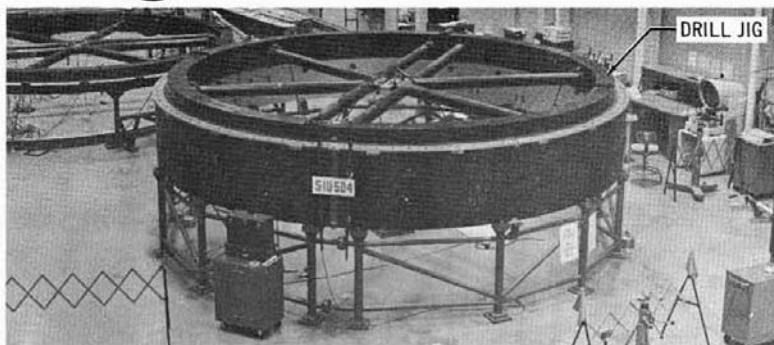

6. INTERFACE-HOLE DRILL JIG INSTALLED



7. FORWARD AND AFT PROTECTIVE RINGS INSTALLED

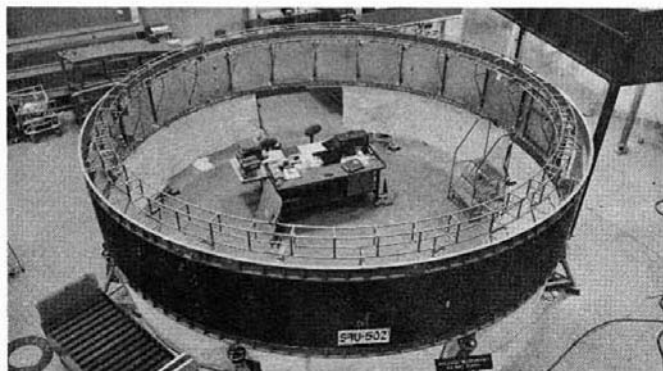

8. CABLE TRAY INSTALLED

IBM N116-2

# STRUCTURAL SYSTEM

## Access Door

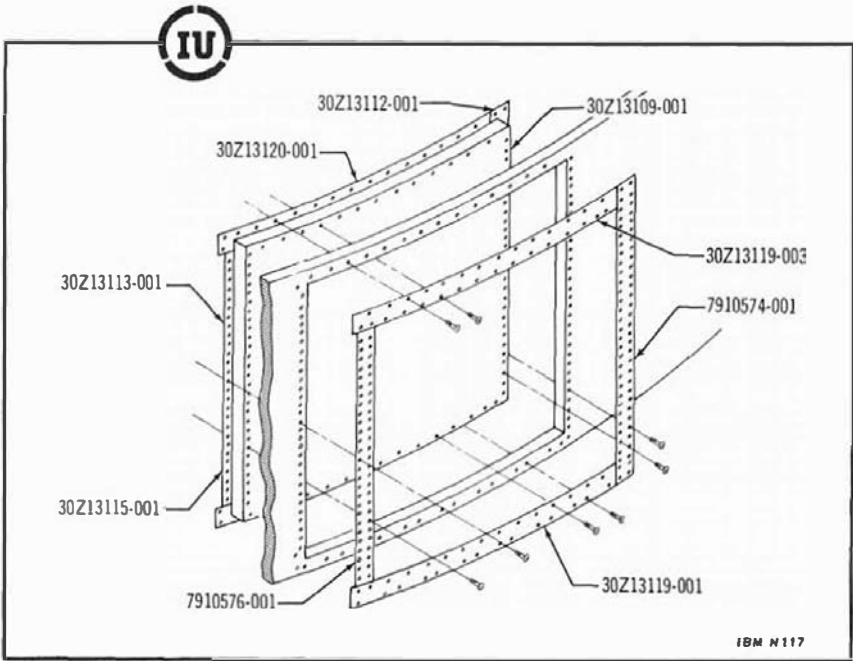

The Access Door, used during prelaunch preparation of the vehicle to facilitate entry into the IU, is constructed of honeycomb sandwich material. When bolted in place, it is an integral, load carrying portion of the structure during flight.

Effectivity: All (Refer to note in Introduction)  
Specification No. Not available  
Figure 1 Location: Panel 8 Callout 42A

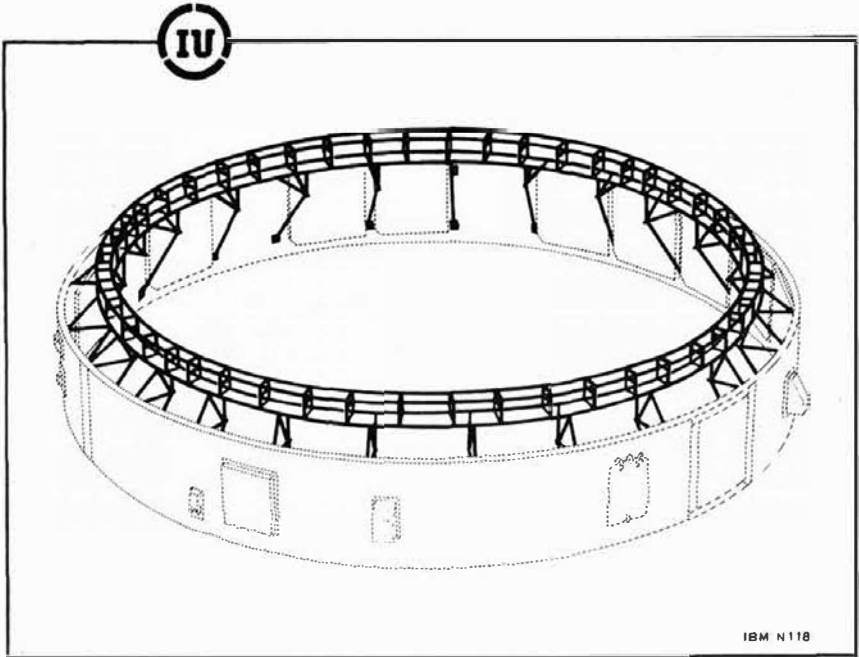

A Cable Tray formed of aluminum alloy tubing is mounted around the inside and above the circular structure. Electrical cables interconnecting components in the IU are laced to and supported by the tray. Also, the tray provides support for the Environmental Conditioning Duct.

Effectivity:	All (Refer to note in Introduction)
Specification No.	Not available

# STRUCTURAL SYSTEM

## Segments

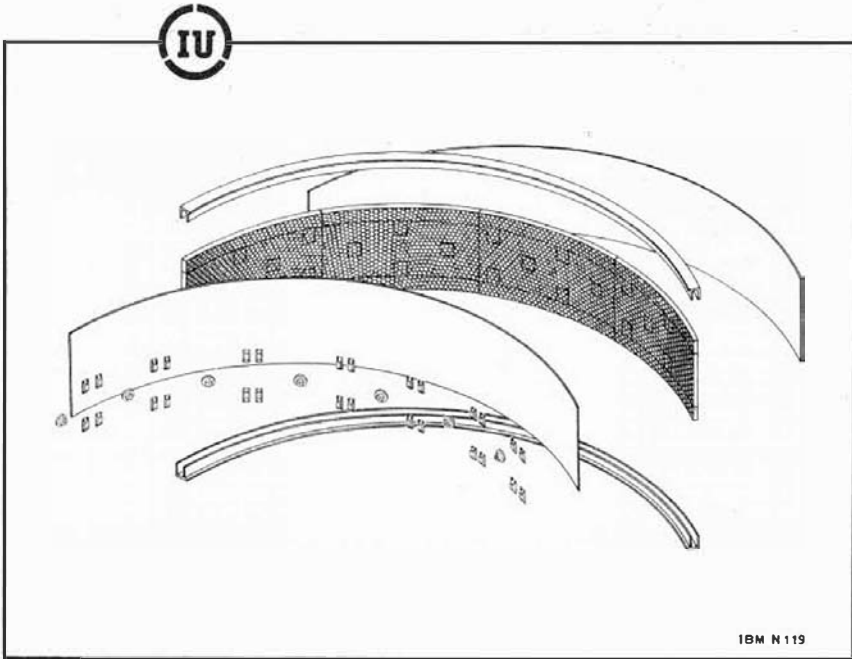

The structure is fabricated from three honeycomb sandwich Segments of equal length. The top and bottom edges are made from extruded aluminum channels bonded to the honeycomb sandwich. Mounting brackets are located on the Segments to hold the components which will be installed in the IU. One Segment contains an Access Door, an Umbilical Panel, and a spring-loaded Umbilical Door.

Effectivity: All (Refer to note in Introduction)  
Specification No. Not available

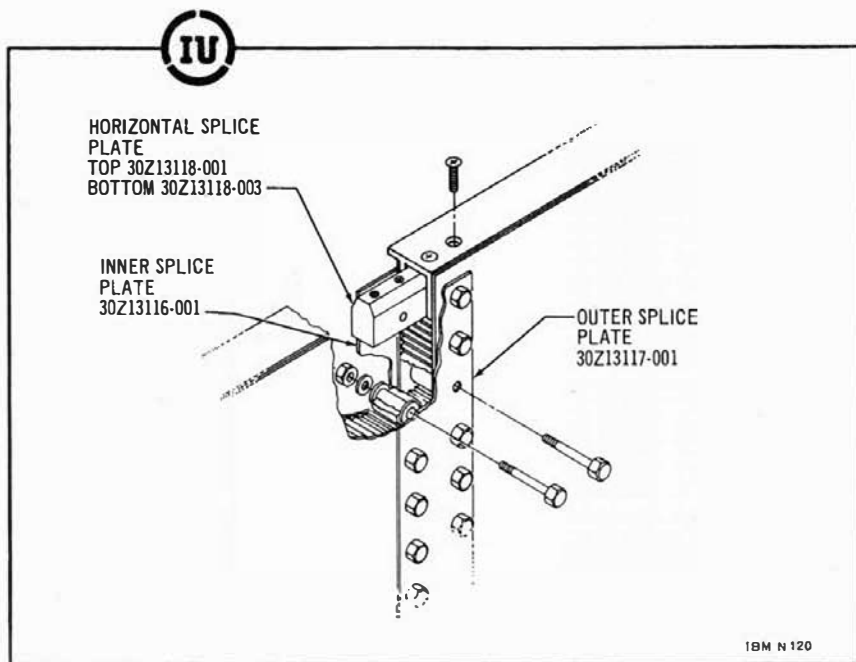

The three segments are mounted on special tools to accurately align them for splicing. Splice plate drill jigs are then clamped to the segments at their junctions, holes are drilled in the segments, and fasteners are installed. Splice Plates are clamped to the segments and back-drilled to match the fastener locations. Then the Splice Plates are bolted to the segments, completing the splices.

Effectivity: All (Refer to note in Introduction)  
Specification No. Not available

# STRUCTURAL SYSTEM

## Umbilical Plate and Umbilical Door

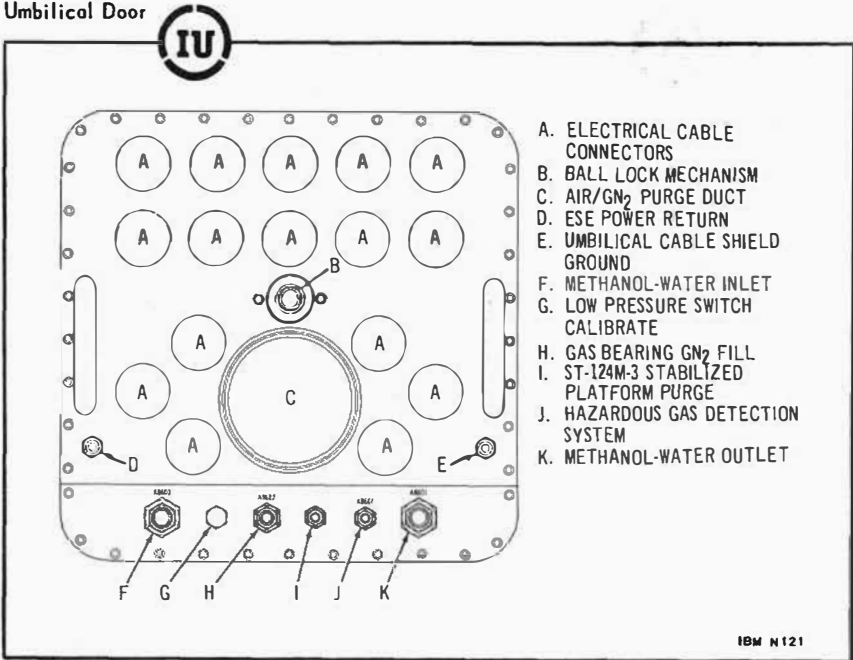

The Umbilical Plate is constructed of solid aluminum and bolted to one of the segments. It facilitates electrical and environmental control connections between the Ground Support Equipment (GSE) and the IU. Prior to launch, many electrical signals provide communications between the vehicle and the GSE. These signals are transferred over cables that are connected to and through the Umbilical Plate. Also, environmental control support is supplied from the GSE through the Umbilical Plate prior to launch. The cable connectors and environmental control quick-disconnect couplings are called out in the above illustration.

The externally mounted Umbilical Door is simply a spring-loaded cover that automatically shuts over the Umbilical Plate when the umbilical pulls loose at launch.

Effectivity:	All (Refer to note in Introduction)
Specification No.	Not available
Figure 1 Location:	Umbilical Plate, Panel 7 Callout 41A

ELECTRICAL  
SYSTEM

## **ELECTRICAL SYSTEM**

The Electrical System of the Saturn IB/V Instrument Unit (IU) distributes and provides switching control of the power required by all IU components during checkout and flight. During prelaunch checkout, power is connected from ground support equipment through the umbilical to the IU components. Batteries supply 28-volt main power during flight.

Electrical System distributors provide junction points and carry out power and measurement sequencing commands received from the Switch Selector during flight or from the ground support equipment during prelaunch checkout. Relays in the distributors apply or remove IU component power and transfer measurements to the Telemetry System, S-IVB Stage, S-IB Stage, and spacecraft.

In addition to the 28-volt battery power, two power supplies furnish voltages required by the Measuring System and the ST-124M Platform Electronic Assembly, they are the 5 Volt Measuring Voltage Supply and the 56 Volt Power Supply.



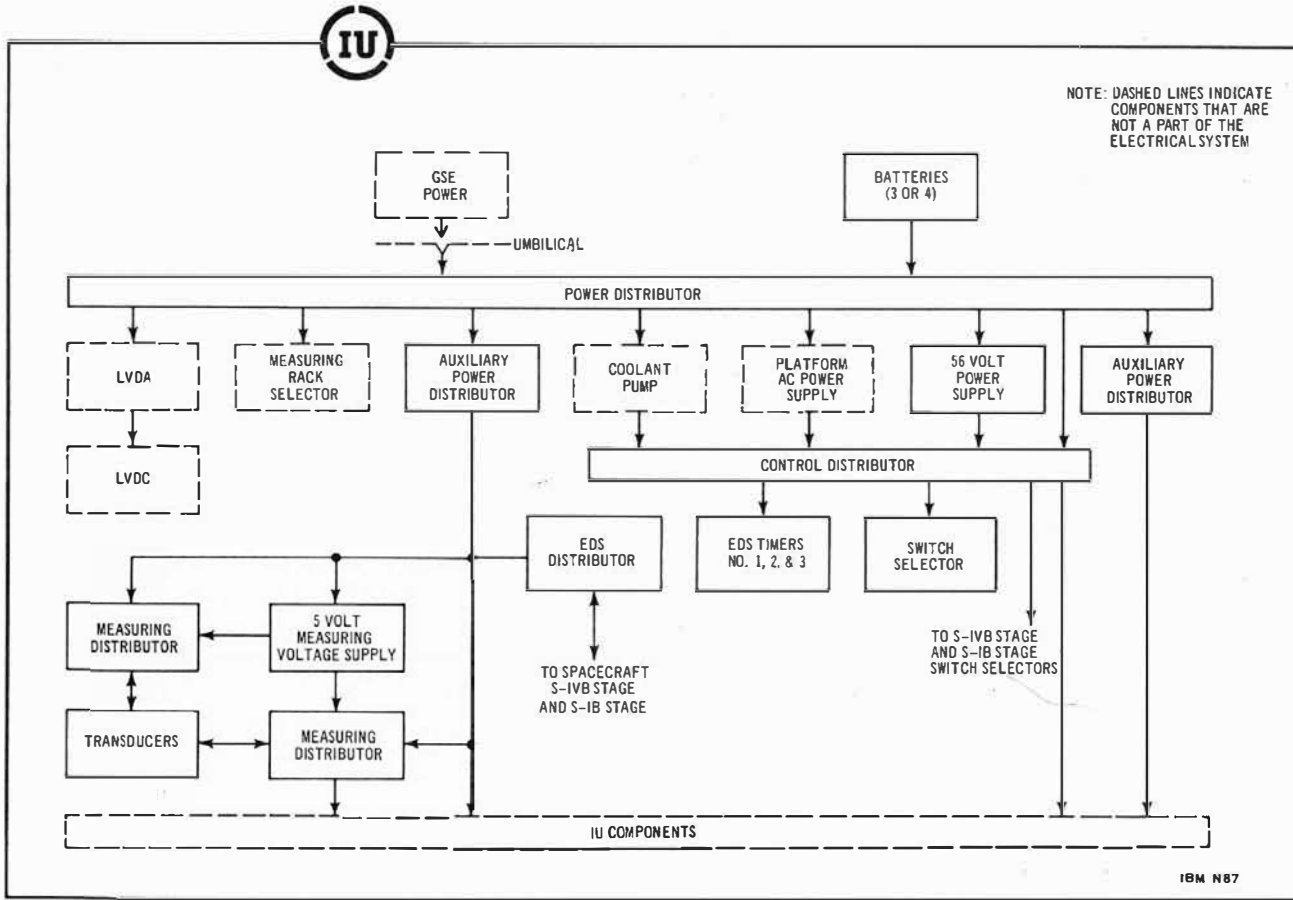

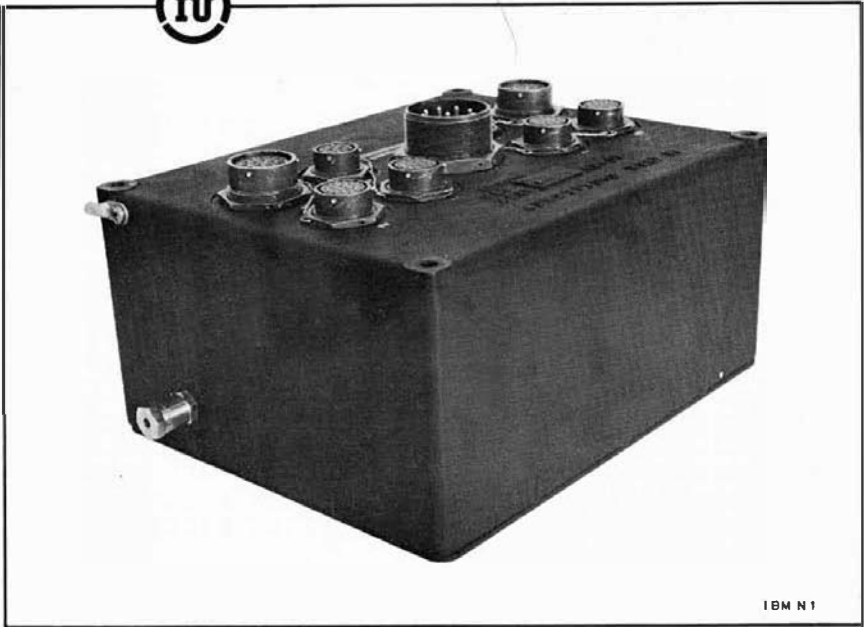

IBM N 1

The two Auxiliary Power Distributors supply 28 Vdc power to small current loads. Both Auxiliary Power Distributors receive 28 Vdc from each of the battery buses in the Power Distributor so that current loads on each of the batteries may be evenly distributed. Relays in the Auxiliary Power Distributors provide power ON/OFF control for IU components during prelaunch checkout and also while in flight. These relays are controlled by the Electrical Support Equipment (ESE) and the Switch Selector.

Effectivity: All (Refer to note in Introduction)  
Specification No. 40M39524  
Figure 1 Location: Panels 1 and 9 Callouts 4 and 51

## ELECTRICAL SYSTEM

### Batteries

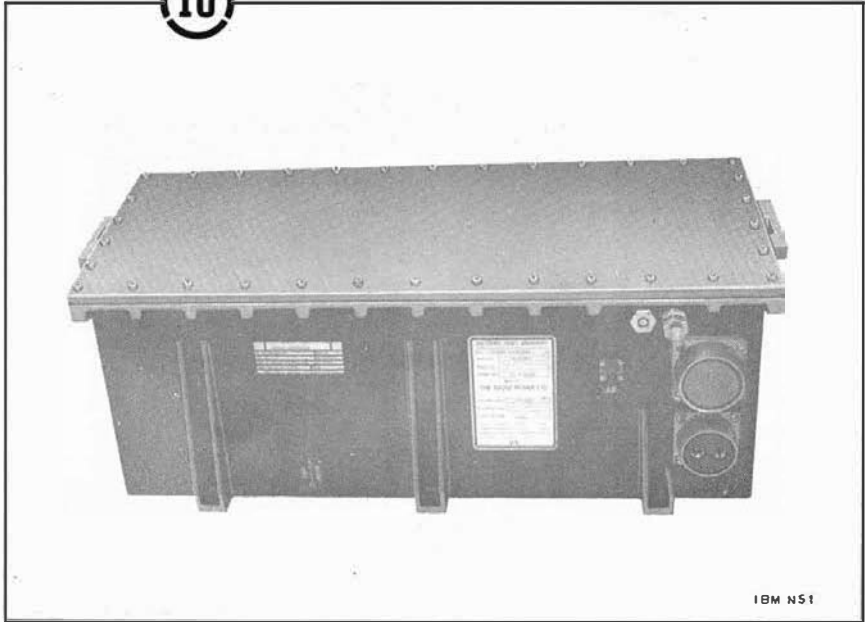

Inflight power for the entire IU is furnished by a maximum of four 28-Vdc batteries. The batteries are silver-zinc dry-charged, capable of supplying 28 Vdc at 35 amperes for a period of 10 hours. All batteries have the same manufacturer's part number and are interchangeable with respect to installation and performance.

Effectivity:	All (Refer to note in Introduction)
Specification No.	40Z20793
Figure 1 Location:	Panels 4 and 5 Callouts 26, 27, 28, and 32



IBM N2

The Control Distributor serves as an auxiliary power distributor for IU segment 603, distributing 28-volt power to small current loads. Also, it distributes 56 Vdc from the 56 Volt Power Supply to the ST-124M-3 Inertial Platform Assembly. In general, it serves as the power distribution center for guidance, control, and some telemetry equipment. The Control Distributor provides power and signal switching during prelaunch checkout for testing various guidance, control, and Emergency Detection System functions. During flight, it performs flight sequencing functions requested by the Launch Vehicle Data Adapter through the Switch Selector. The Control Distributor contains some of the logic required for proper sequencing of the vehicle flight functions.

Effectivity:	All (Refer to note in Introduction)
Specification No.	40M39521
Figure 1 Location:	Panel 18 Callout 97

## ELECTRICAL SYSTEM

### EDS Distributor

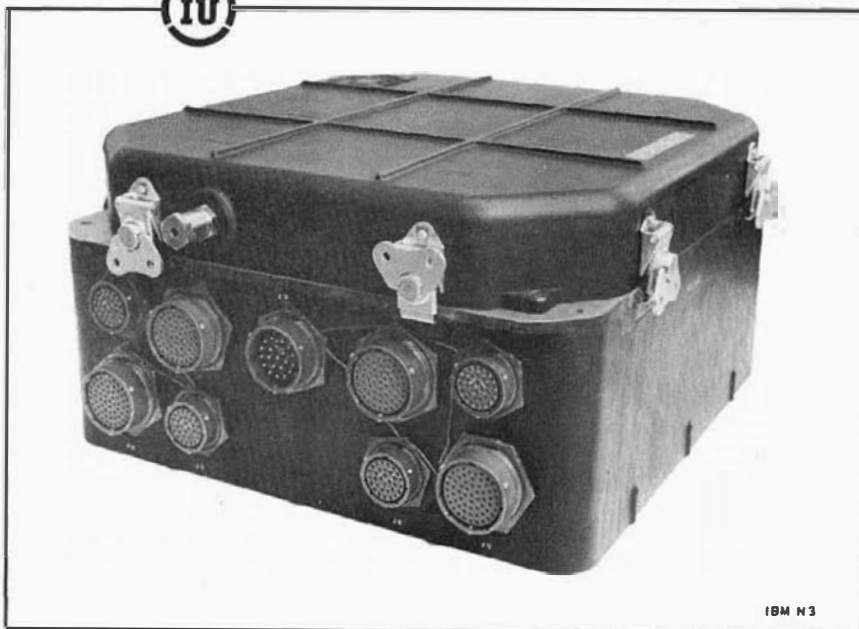

IBM N3

The Emergency Detection System (EDS) Distributor is a junction and switching box furnishing the EDS display panel in the spacecraft with emergency signals if malfunctions occur in the launch vehicle stages. The distributor also contains relay and diode logic for the automatic abort system.

Effectivity: All (Refer to note in Introduction)  
Specification No. 40M39522  
Figure 1 Location: Panel 14 Callout 66

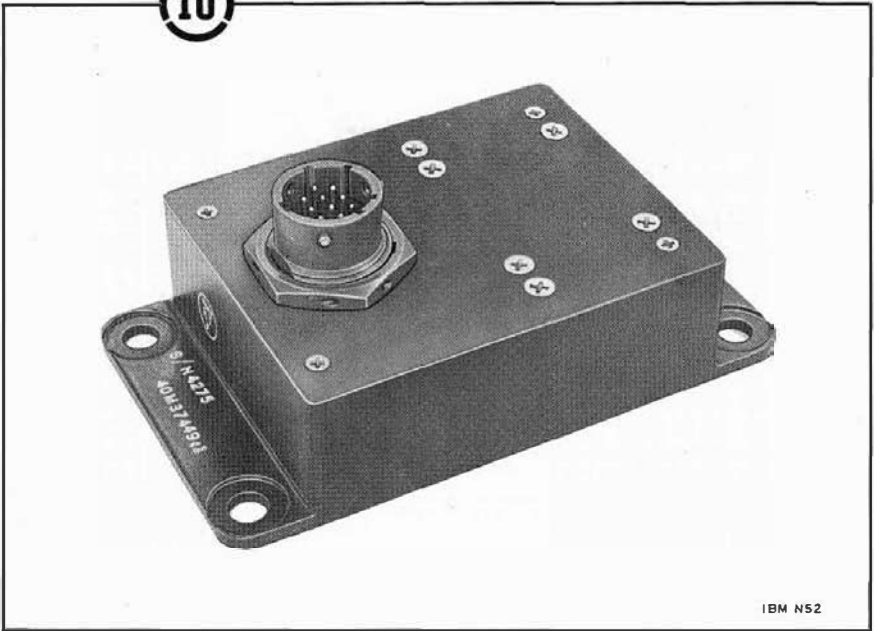

IBM N52

**EDS Timer No. 1** An electronic timing device used as a backup for one channel of the Switch Selector. The timer is actuated at lift-off and produces an output 30 or 40 seconds after being actuated. The output from the timer will energize relays in the EDS Distributor that allow multiple engine cutoff. During the first 30 or 40 seconds of flight, engine cutoff is prevented in order to keep the launch vehicle from falling within the safety fallback area.

**EDS Timer No. 2** An electronic timing device used as a backup for one channel of the Switch Selector. The timer is actuated at lift-off and produces an output 20 seconds after being actuated. The output from the timer will energize relays in the EDS Distributor that make an inflight change to EDS angular overrate limits; from 3 degrees during the first 20 seconds of flight to 5 degrees thereafter.

**EDS Timer No. 3** Performs the same functions as timer No. 1 except that it produces an output 60 seconds after lift-off.

**Effectivity:** No. 1 40 seconds 201, 203, 204, 205, 207, &  
209-212/501-502  
30 seconds 503-515

No. 2 204-212/501-515

No. 3 202, 206, & 208

**Specification No.** 40Z39536

**Figure 1 Location:** No. 1 Panel 17 Callout 88

No. 2 Panel 17 Callout 87

No. 3 Panel 17 Callout 88

## ELECTRICAL SYSTEM

### Measuring Distributors



IBM N4

The primary function of the Measuring Distributors is to collect all measurements that are transmitted by the IU telemetry system, and to direct them to their proper telemetry channels. These measurements are obtained from instrumentation transducers, functional components, and various signal and control lines. Also, the Measuring Distributors distribute the 5-volt output from the 5 Volt Measuring Voltage Supply throughout the measuring system.

Effectivity: All (Refer to note in Introduction)  
Specification No. 40M39514  
Figure 1 Location: Panels 10 and 13 Callouts 48 and 67



IBM N5

The Plug Type J-Box Assembly is basically a plug with groups of its pins jumpered together to provide common return paths for circuitry contained in the ST-124M-3 Platform Electronic Assembly.

Effectivity:	All (Refer to note in Introduction)
Specification No.	Not available
Figure 1 Location:	Panel 20 Callout 102



# ELECTRICAL SYSTEM

## Power Distributor

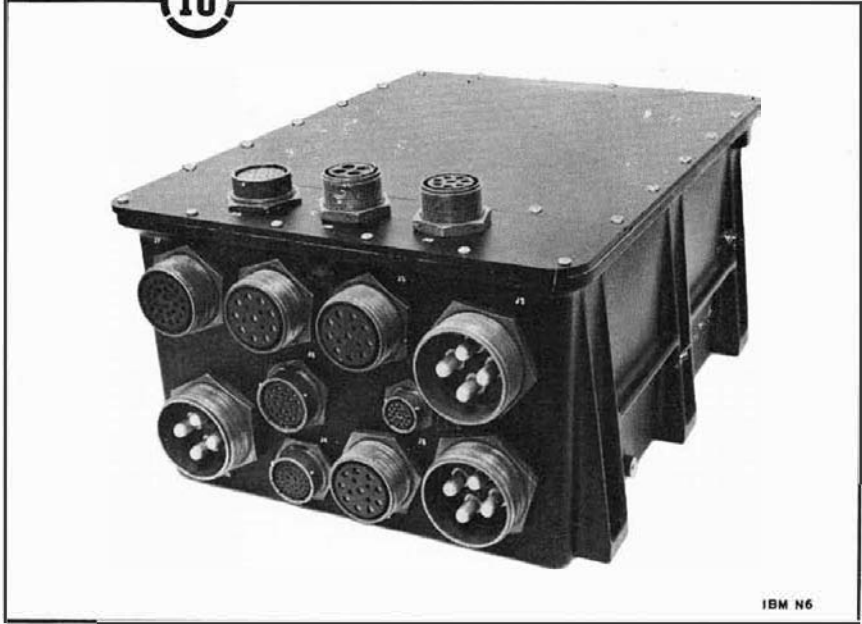

The Power Distributor provides the primary distribution for all 28-volt power required by IU components. Inflight 28-volt battery power, or prelaunch Electrical Support Equipment 28-volt power, is distributed by the Power Distributor

Effectivity: All (Refer to note in Introduction)

Specification No. 40M39523

Figure 1 Location: Panel 2 Callout 2

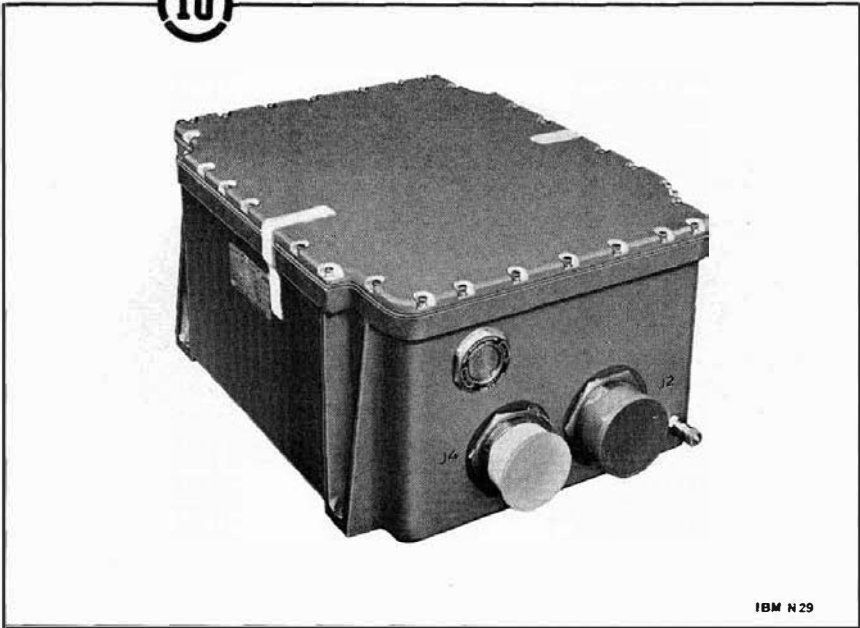

IBM N 29

The IU Switch Selector is the connecting link between the LVDA/LVDC, which generate the flight sequence commands, and the circuitry in the IU where the command is to be executed. The Switch Selector consists of solid-state and relay circuits which decode the digital flight sequence command from the LVDA/LVDC and activate the proper IU circuits to execute the command.

Effectivity:	Switch Selector Mod I	201
	Switch Selector Mod II	202-212/501-515
Specification No.	Switch Selector Mod I	50M04008
	Switch Selector Mod II	6009026
Figure 1 Location:	Panel 17 Callout 80	

## ELECTRICAL SYSTEM

### 5 Volt Measuring Voltage Supply

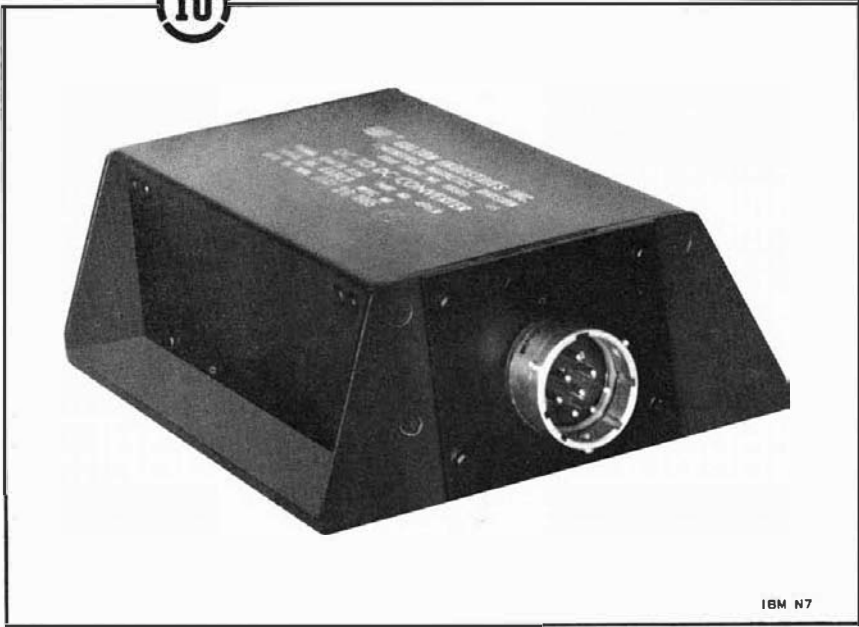

The 5 Volt Measuring Voltage Supply converts 28 Vdc main power to highly regulated 5 Vdc power for use throughout the IU measuring system. It is primarily used as an excitation voltage for various measurement sensors and as a calibration voltage for telemetry channels and signal conditioning modules. The 5-volt output of the supply is applied to the Measuring Distributors which distribute the 5 Vdc throughout the measuring system.

Effectivity:	All (Refer to note in Introduction)
Specification No.	7907178
Figure 1 Location:	Panel 12 Callout 72

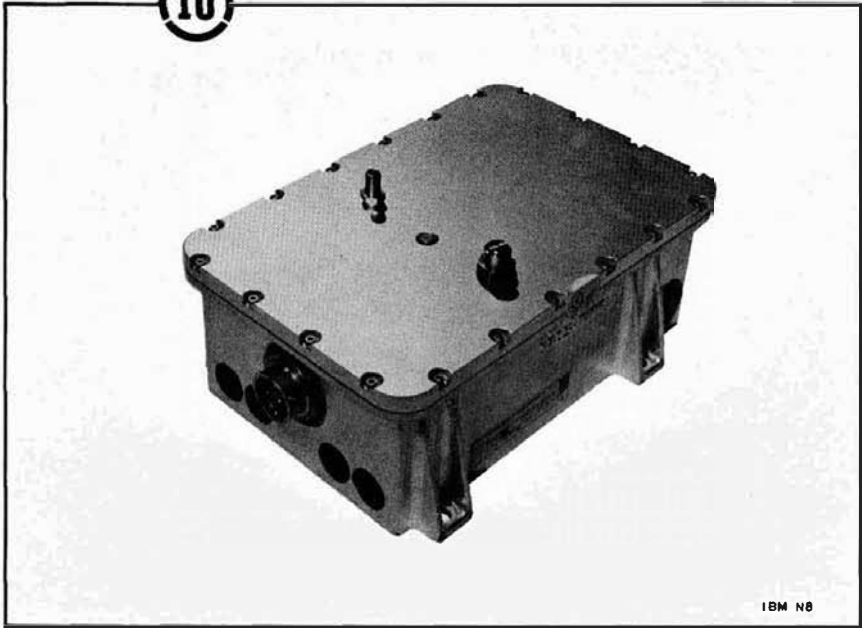

The 56 Volt Power Supply converts unregulated 28 Vdc battery power to regulated 56 Vdc power required by the ST-124M-3 Inertial Platform Subsystem. This power supply provides B+ voltage needed by the stabilization and accelerometer amplifiers, and the accelerometer signal conditioners. It is basically a dc-to-dc converter that uses a magnetic amplifier as a control unit. The 56 Volt Power Supply is connected to the platform electronic assembly through the Power and Control Distributors.

Effectivity: All (Refer to note in Introduction)  
Specification No. 50Z60223  
Figure 1 Location: Panel 1 Callout 11



## ENVIRONMENTAL CONTROL SYSTEM

The Environmental Control System controls liquid and gaseous elements of the IU to provide a satisfactory operational environment for all components mounted within the IU and at the top of the S-IVB Stage. The Environmental Control System consists of:

- The gas bearing supply system that furnishes gaseous nitrogen ( $\text{GN}_2$ ) at a regulated pressure and temperature to the ST-124M-3 Inertial Platform Assembly. The  $\text{GN}_2$  permits the ST-124M-3 gyros to operate in a nearly frictionless environment.
- The thermal conditioning system that maintains a stable acceptable temperature for components located and operating within the IU and the upper portion of the S-IVB Stage during preflight and flight conditions.
- The IU preflight air/ $\text{GN}_2$  purge system that maintains an inert environment in the IU/S-IVB compartment by furnishing a temperature and pressure regulated supply of filtered air or  $\text{GN}_2$  to the compartment.
- The hazardous gas detection system that samples the IU atmosphere for dangerous levels of oxygen and/or hydrogen during prelaunch checkout.

Environmental Control System Block Diagram

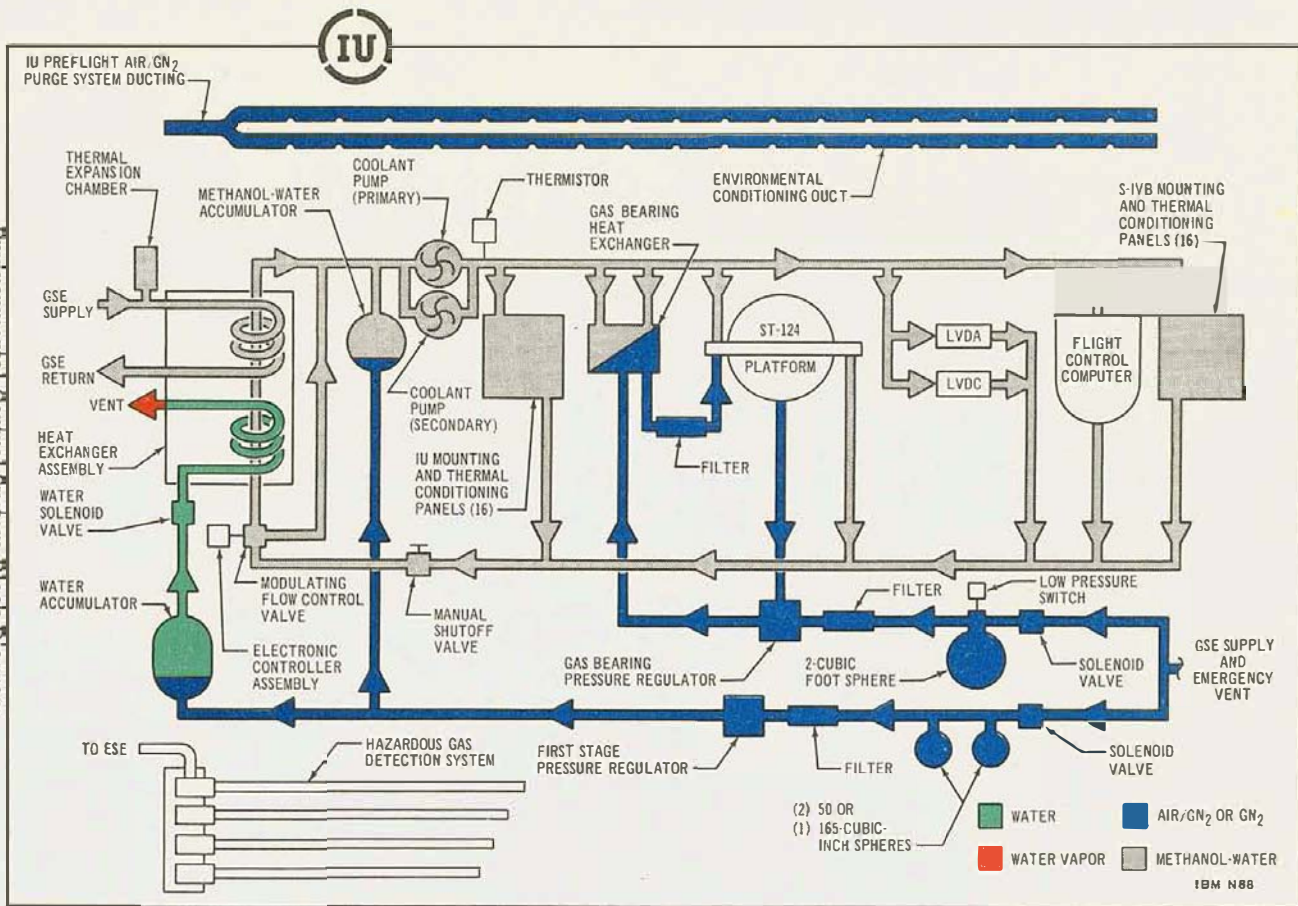



Environmental Control System Panel 3 (Typical 206-212/502-515)



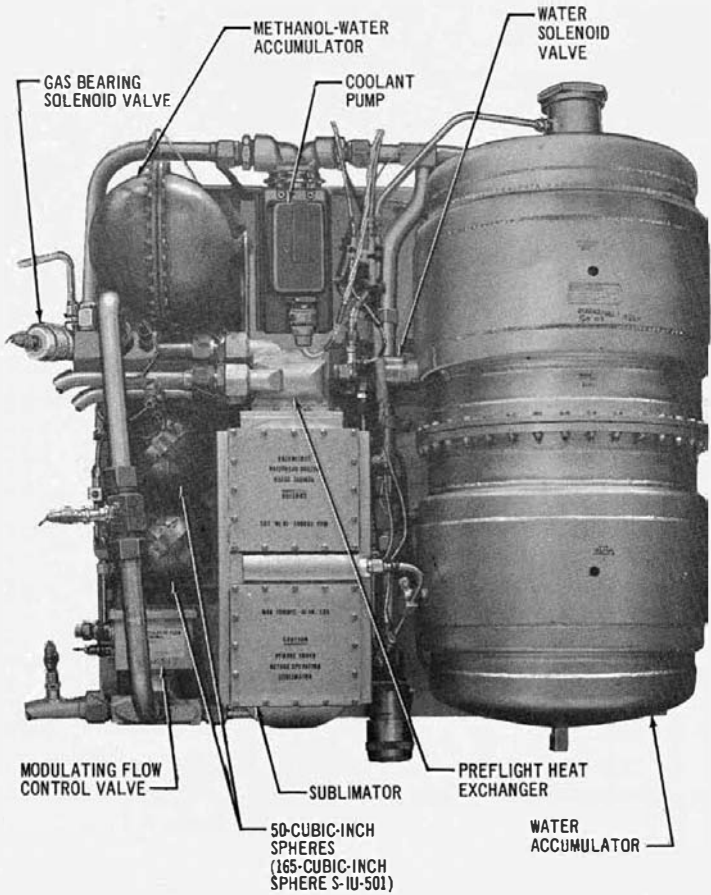

IBM N111

Environmental Control System Panel 6 (Typical 201-205/501)



(SMALL ACCUMULATOR SHOWN -  
A LARGER ACCUMULATOR IS USED ON  
LATER VEHICLES. SEE TABLE 1 FOR  
EFFECTIVITIES.)

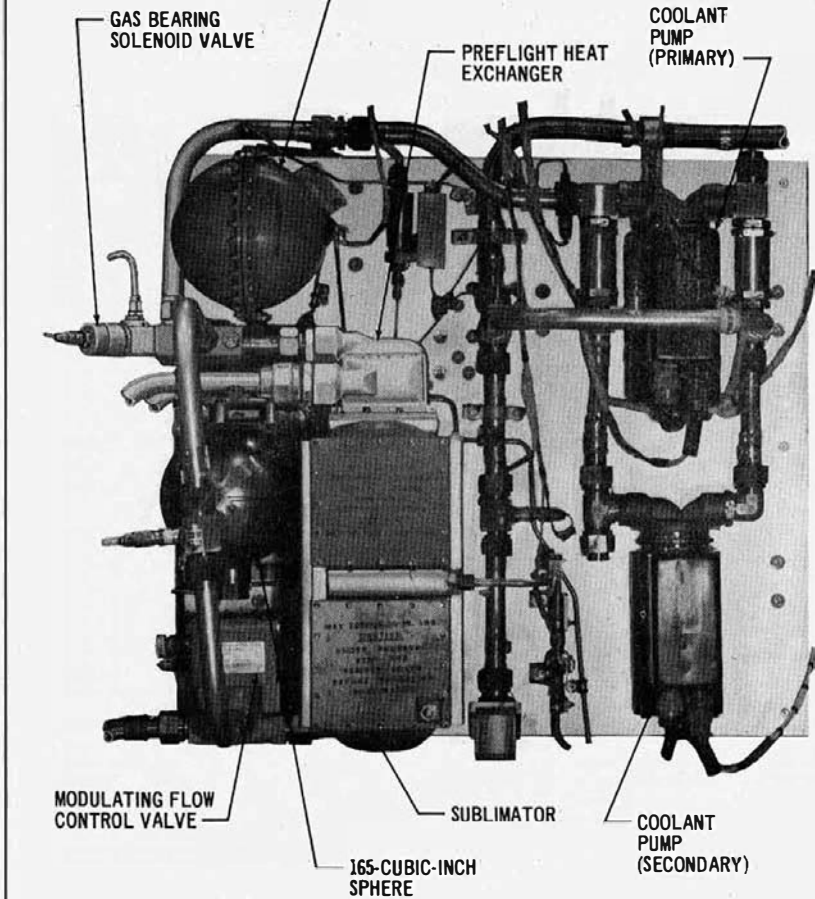

IBM N123

Environmental Control System Panel 6 (Typical 206-212/502-515)

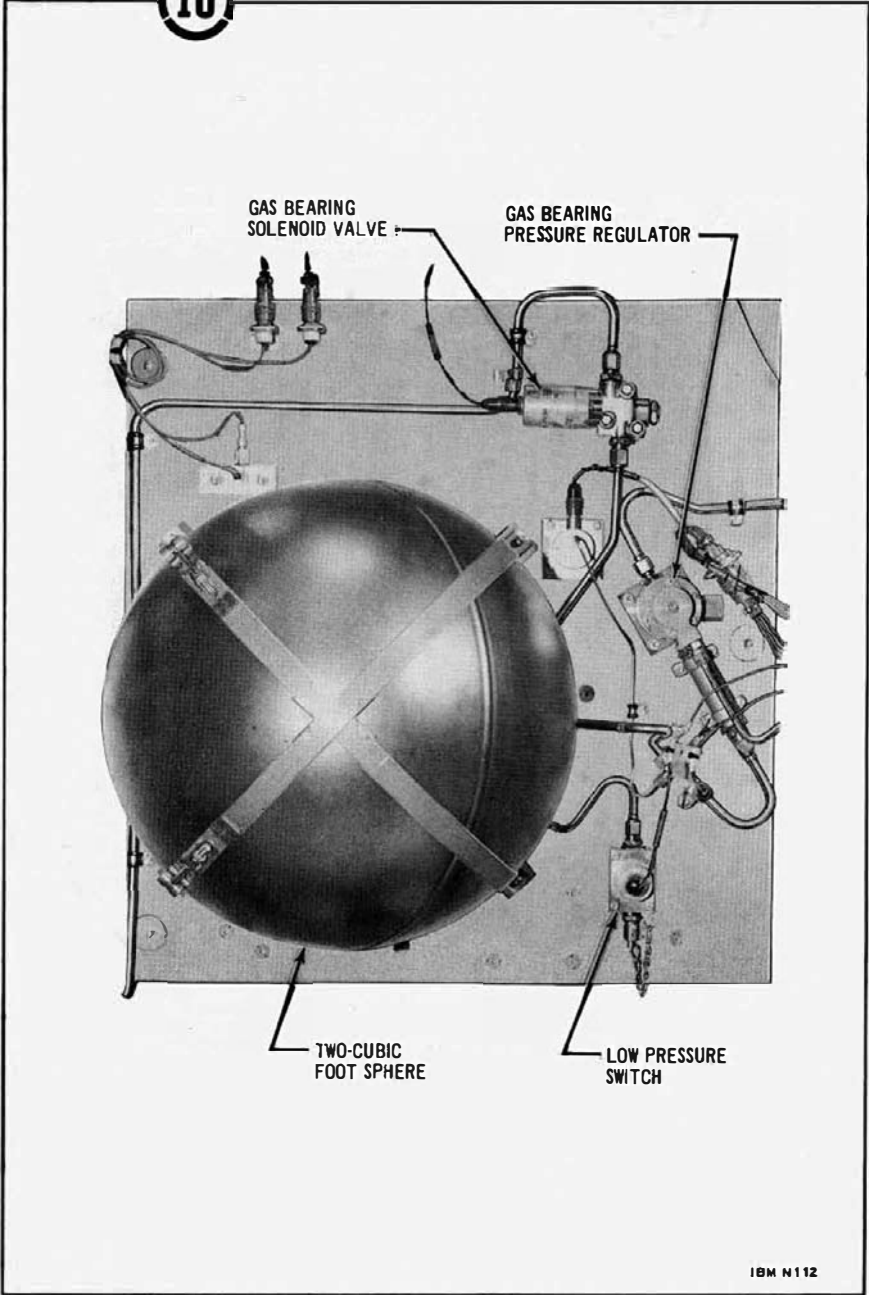

IBM N112

Environmental Control System Panel 22 (Typical)

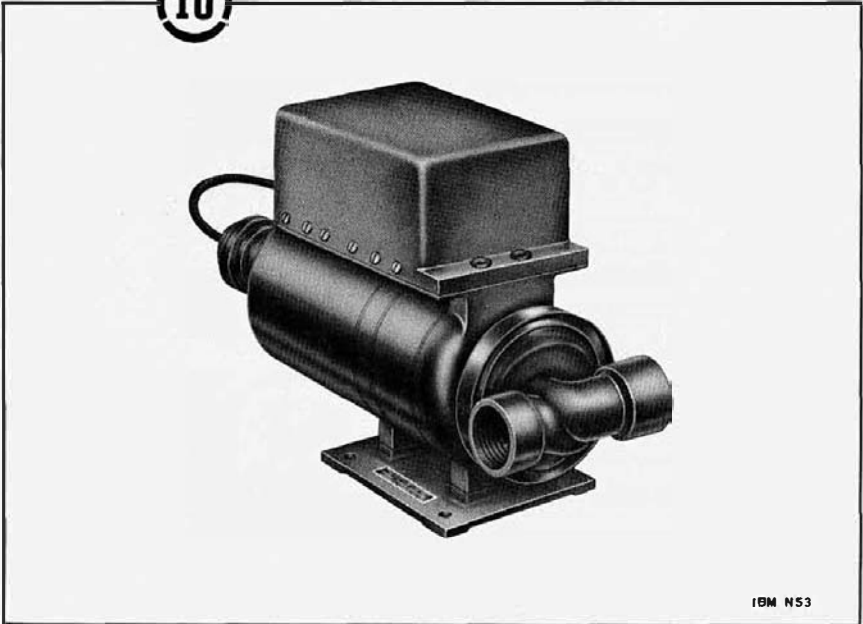
**IU**

The Coolant Pump circulates a water/methanol solution through the thermal conditioning system in the IU. The Coolant Pump consists of an electric drive motor and centrifugal pump which is designed to operate for 1000 hours continuously.

One Coolant Pump is used on S-IU-201-205/501-502. Onboard S-IU-206 and subsequent, and S-IU-503 and subsequent 2 pumps are used. The latter are provided with a standby pump to improve the probability that coolant flow will be maintained.

Effectivity: All (Refer to note in Introduction)  
Specification No. 20Z42001  
Figure 1 Location: Panel 6 Callouts 35, 44A, and 44B

# ENVIRONMENTAL CONTROL SYSTEM

## Environmental Conditioning Duct

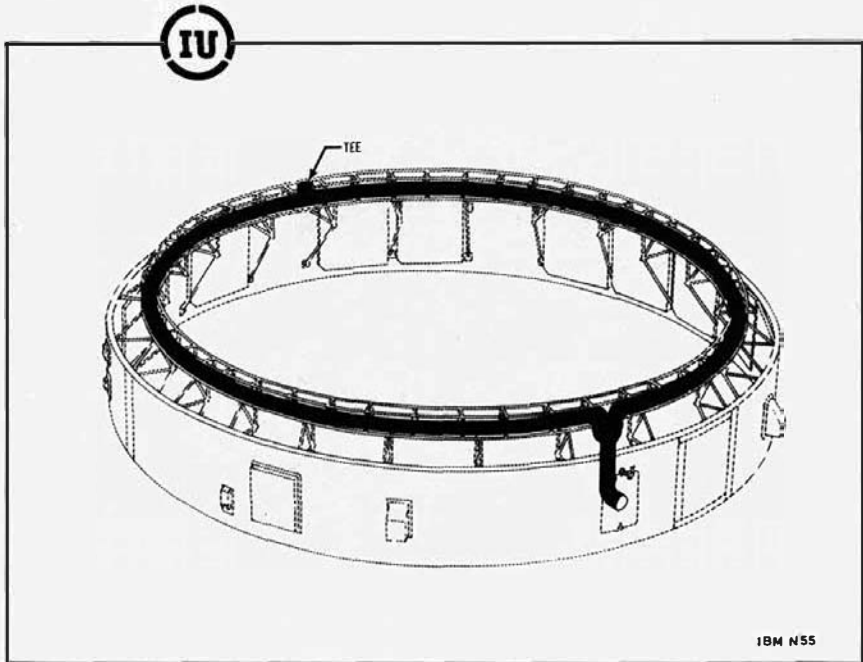

The Environmental Conditioning Duct is that part of the preflight air/ $\text{GN}_2$  purge system contained in the IU. The Environmental Conditioning Duct distributes the temperature and pressure regulated, ground supplied, filtered air or  $\text{GN}_2$  throughout the IU/S-IVB compartment through orifices in the duct. During the preflight phases of IU checkout, the function of the purge system is to provide ventilating air. During fueling operations, its function is to maintain an inert  $\text{GN}_2$  atmosphere within the IU compartment, thus preventing the accumulation of dangerous or corrosive gases which might affect operation or safety. Purging of the IU/S-IVB compartment terminates with umbilical separation.

Effectivity:	All (Refer to note in Introduction) except for Tee, which has effectivities as given in Table 1.
Specification No.	Not available
Figure 1 Location:	All panels Callout 3

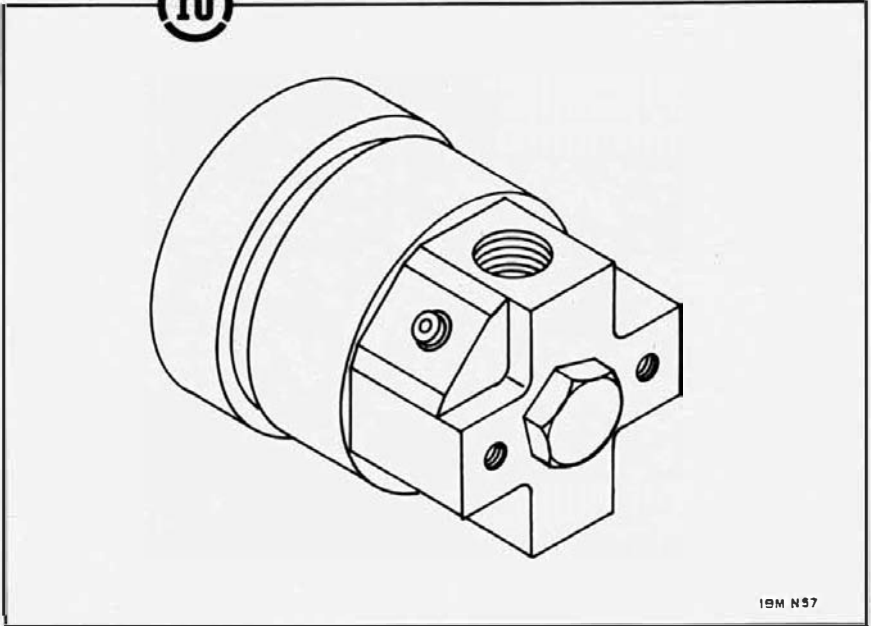

IBM N57

The methanol-water accumulator and water accumulator are pressurized with  $\text{GN}_2$  that is stored at 3000 psig in the two 50-cubic-inch or the 165-cubic-inch storage spheres. The  $\text{GN}_2$  is reduced to approximately 15 psia by the First Stage Pressure Regulator, and then applied to the methanol-water accumulator. After being further reduced to 5 psia by the orifice regulator, the  $\text{GN}_2$  is applied to the water accumulator.

Effectivity: All (Refer to note in Introduction)  
Specification No. 20Z42013  
Figure 1 Location: Panel 6 Callout 33

# ENVIRONMENTAL CONTROL SYSTEM

## Gas Bearing Heat Exchanger

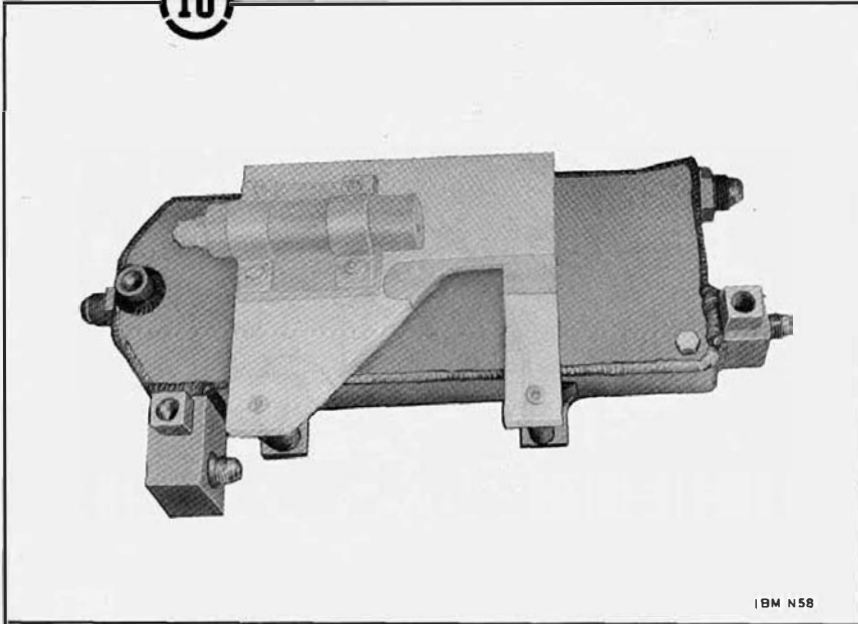

IBM N58

The gaseous nitrogen ( $GN_2$ ) used to lubricate the ST-124M-3 platform gas bearings is cooled or heated, as required, as it passes through the Gas Bearing Heat Exchanger.

Effectivity: All (Refer to note in Introduction)

Specification No. 20Z42004

Figure 1 Location: Panels 21 and 22 Callouts 111, 121, 123A, and 124

ENVIRONMENTAL CONTROL SYSTEM  
Gas Bearing Pressure Regulator

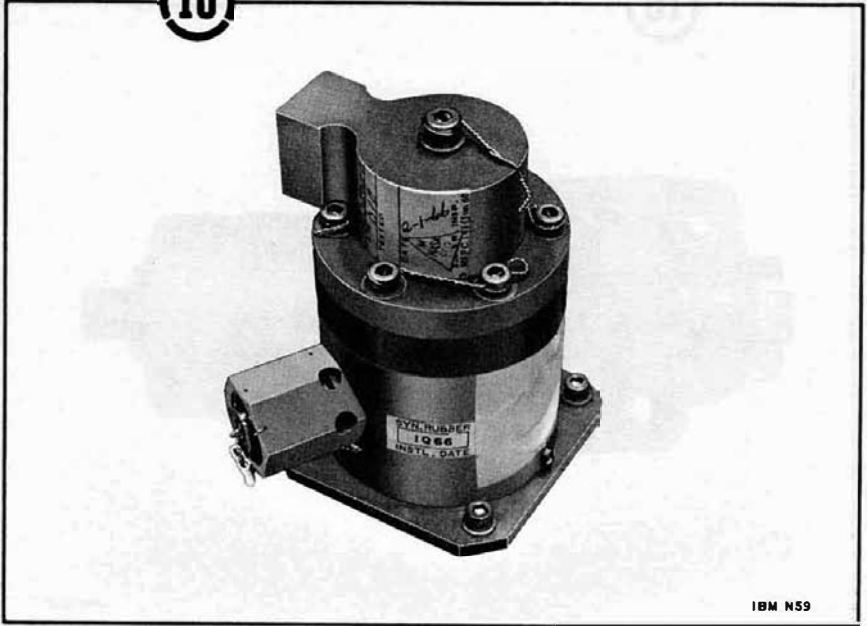

IBM N59

A reference pressure is fed-back from the platform to the pressure regulator. This feed-back reference pressure maintains the pressure in the gas bearings constant by controlling the pressure regulator output pressure; i. e., a decrease in pressure in the gas bearings causes the pressure regulator output to increase.

Effectivity: All (Refer to note in Introduction)  
Specification No. 20Z42012  
Figure 1 Location: Panel 22 Callout 115



## ENVIRONMENTAL CONTROL SYSTEM

### Gas Bearing Solenoid Valves

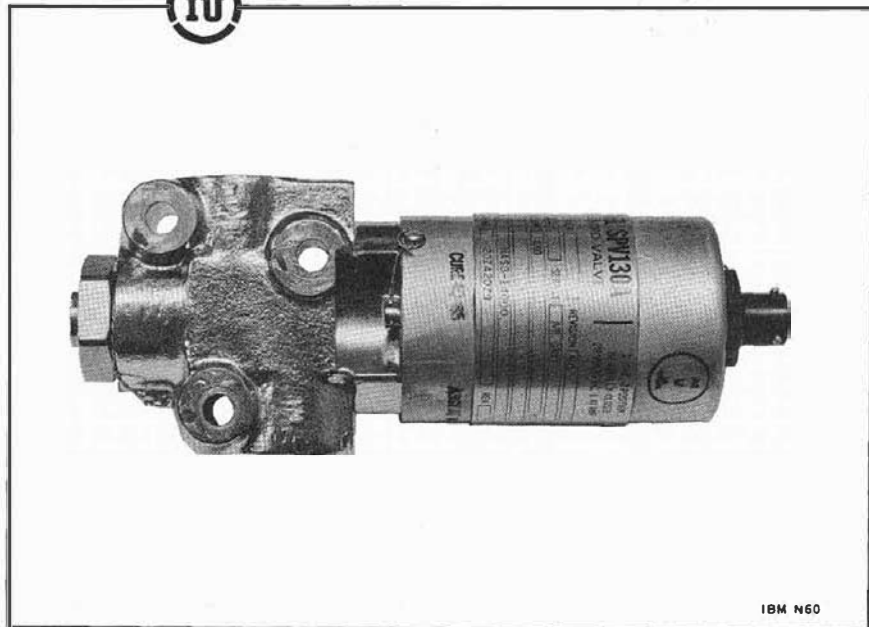

The Gas Bearing Solenoid Valves are used during  $\text{GN}_2$  filling of the Two-Cubic-Foot Sphere and the 50 or 165-Cubic-Inch Spheres. The valve is a two-position, normally-closed, poppet-type, two-way valve. When the pressure in the spheres is approximately 3000 psig, the valves are closed and the  $\text{GN}_2$  source can be removed.

Effectivity: All (Refer to note in Introduction)  
Specification No. 20Z42079  
Figure 1 Location: Panel 22 Callout 118

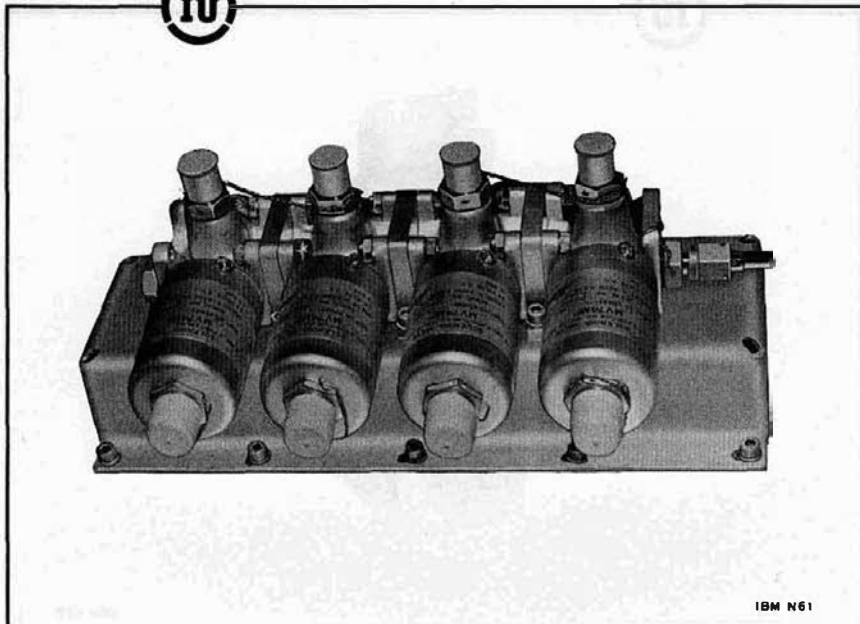

The Hazardous Gas Manifold located in the IU is a part of the overall "sniffer system." Four tubes extend from shut-off valves on the manifold to various parts of the IU atmosphere. The samplings are transferred to the ground via the umbilical to be analyzed for dangerous levels of oxygen and/or hydrogen.

The manifold and valves are not used in S-IU-204 and subsequent. The four sampling tubes are connected to one common tube by the use of tee connectors. This common tube is in turn connected to the umbilical. In both cases the sampling terminates with umbilical separation.

Effectivity: 201-203  
Specification No. Not available  
Figure 1 Location: Panel 7 Callout 42

# ENVIRONMENTAL CONTROL SYSTEM

## Heat Exchanger Assembly



IBM N62

The Heat Exchanger Assembly consists of a preflight heat exchanger and a sublimator. During prelaunch operations, the preflight heat exchanger is supplied a temperature controlled, methanol-water mixture by the ground support equipment (GSE). This GSE supplied mixture is circulated through one side of the preflight heat exchanger, thus cooling the closed-loop methanol-water coolant that flows through the other section (IU side) of the heat exchanger. The preflight heat exchanger provides a means to maintain a desired coolant temperature during prelaunch operations. The sublimator is used to dissipate heat from the IU components during flight. Heat dissipation is accomplished by two basic mechanisms, sublimation and evaporation.

- Effectivity: All (Refer to note in Introduction)
- Specification No. 20Z42159
- Figure 1 Location: Panel 6 Callout 38

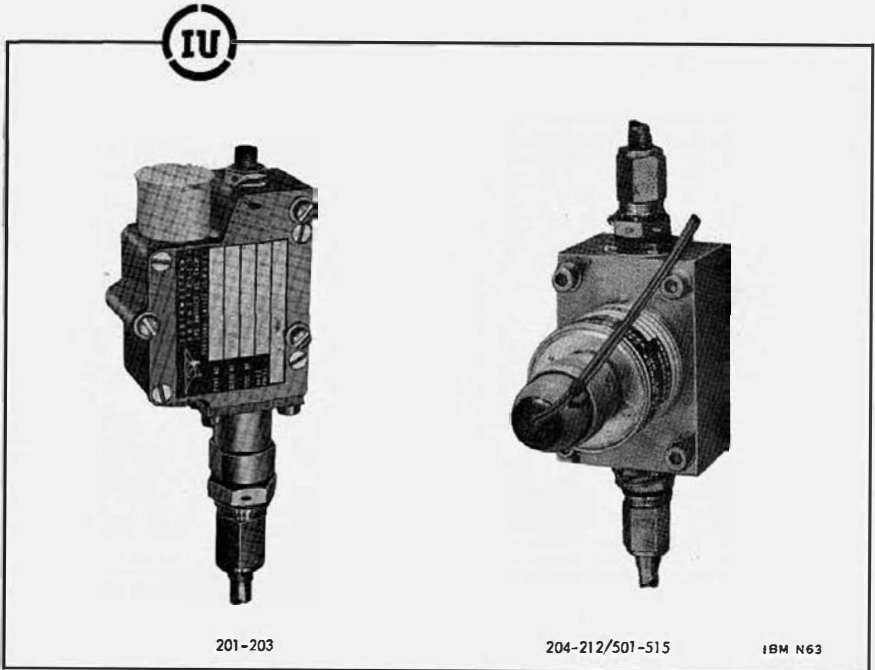

If nitrogen pressure within the 2-cubic-foot GN<sub>2</sub> storage sphere falls below 925 psia during preflight operation, the Low Pressure Switch initiates shut-down of the ST-124M-3 platform. This switch is inactive during flight.

Effectivity:	All (Refer to note in Introduction)	
Specification No.	201-203	20M42131
	204-212/501-515	20Z42016
Figure 1 Location:	Panel 22 Callout 116	

# ENVIRONMENTAL CONTROL SYSTEM

## Methanol-Water Accumulator

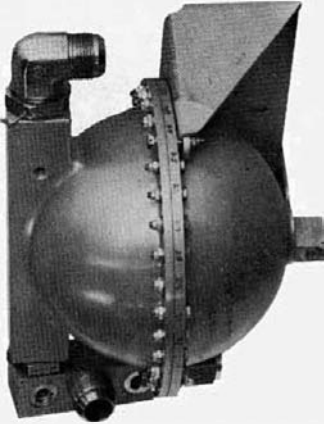

201-205/501-503



206-212/504-515

IBM N64

The Methanol-Water Accumulator compensates for the coolant thermal expansion and provides make-up fluid for any fluid lost due to leakage. A rubber bladder within the accumulator separates the methanol-water and  $\text{GN}_2$  used for pressurization. The  $\text{GN}_2$ , acting through the Methanol-Water Accumulator, keeps a constant inlet pressure to the Coolant Pump. The capacity of the Methanol-Water Accumulator for IU 206-212/503-515 is twice that of the accumulator for IU 201-205/501-502, but the basic concept and use remains the same.

Effectivity:	All (Refer to note in Introduction)
Specification No.	20Z42078
Figure 1 Location:	Panel 6 Callout 34

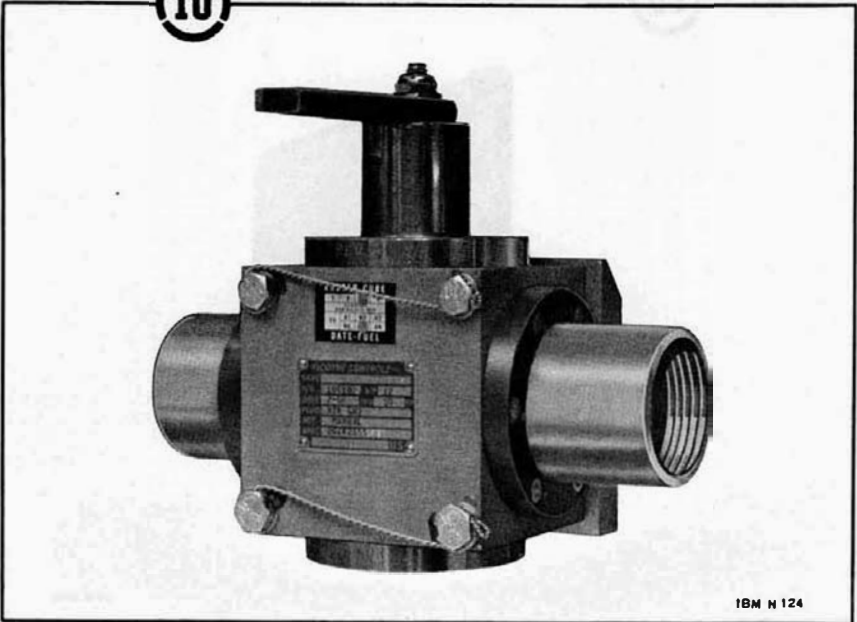

The manually operated Shutoff Valve has no inflight function and is used only during filling or draining of the Environmental Control System with methanol-water coolant. The Manual Shutoff Valve is closed and opened during servicing to assure complete methanol-water filling or draining of the system. During operation of the system, the Manual Shutoff Valve is lockwired in the open position.

Effectivity: 203-212/501-515  
Specification No. Not available  
Figure 1 Location: Panel 7 Callout 41

# ENVIRONMENTAL CONTROL SYSTEM

## Mounting and Thermal Conditioning Panels

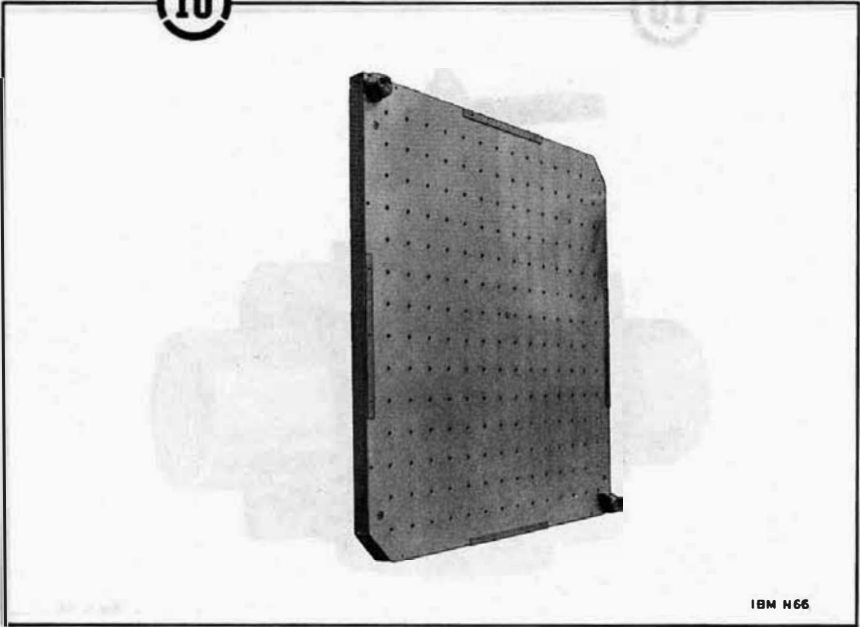

IBM H66

The Mounting and Thermal Conditioning Panels are used as mounting surfaces and heat dissipation paths for the electrical and electronic equipment onboard the IU. The heat dissipation is accomplished by liquid coolant flowing through the panels.

Effectivity: All (Refer to note in Introduction)  
Specification No. 20Z42000  
Figure 1 Location: All

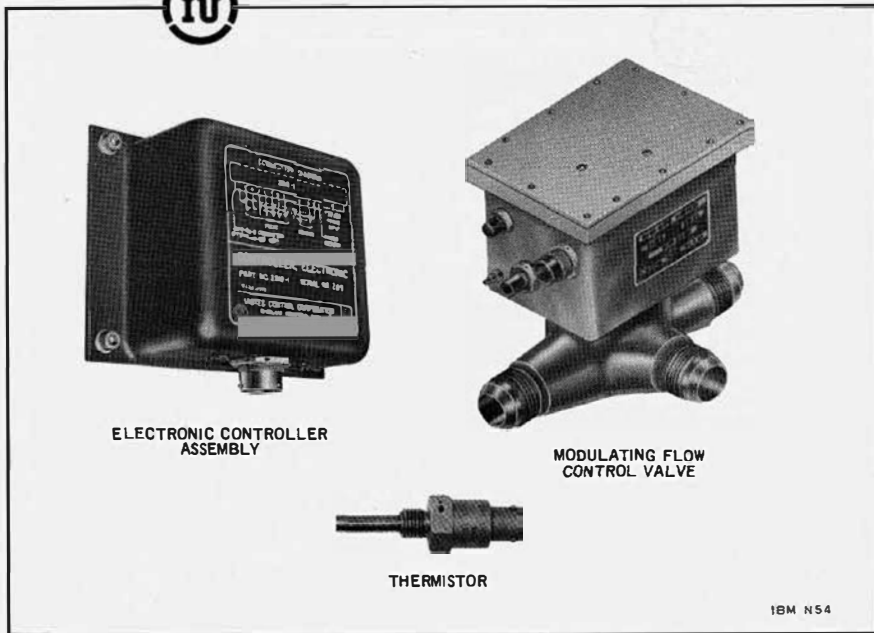
ELECTRONIC CONTROLLER  
ASSEMBLYMODULATING FLOW  
CONTROL VALVE

THERMISTOR

IBM NS4

The Temperature Control Assembly is made up of three separate components; the Electronic Controller Assembly, the Modulating Flow Control Valve, and a temperature sensing thermistor. The thermistor is located downstream from the Coolant Pump and applies a signal to the Electronic Controller Assembly that is proportional to the methanol-water coolant temperature. The Electronic Controller Assembly in turn applies a signal to the Modulating Flow Control Valve which diverts varying amounts of coolant through the Heat Exchanger Assembly if the coolant requires cooling. However, if no cooling is required, the coolant is bypassed around the heat exchanger by the Modulating Flow Control Valve.

Effectivity: All (Refer to note in Introduction)  
 Specification No. 20Z42007  
 Figure 1 Location: Electronic Controller Assembly, Panel 2 Callout 14  
 Modulating Flow Control Valve, Panel 6 Callout 39



# ENVIRONMENTAL CONTROL SYSTEM

## Thermal Expansion Chamber

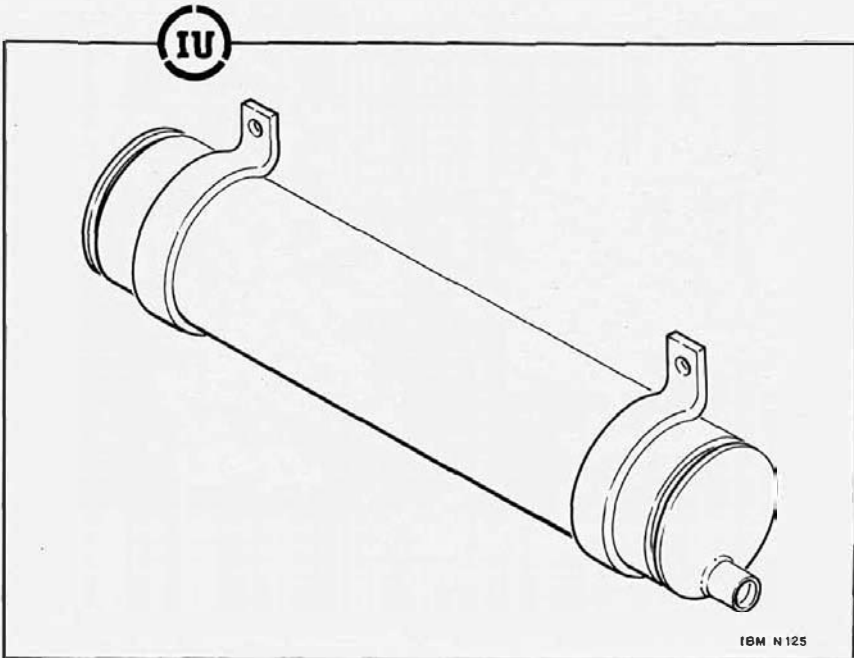

Some of the methanol-water coolant, which is circulated by Ground Support Equipment during preflight operations, is trapped between the umbilical quick disconnects and the preflight heat exchanger at the time of umbilical separation. The Thermal Expansion Chamber, connected into the preflight heat exchanger inlet line, provides for thermal expansion of this trapped coolant during flight.

Effectivity: All (Refer to note in Introduction)  
Specification No. Not available  
Figure 1 Location: Panel 7 Callout 32A

ENVIRONMENTAL CONTROL SYSTEM  
Thermal Conditioning Panel Heaters

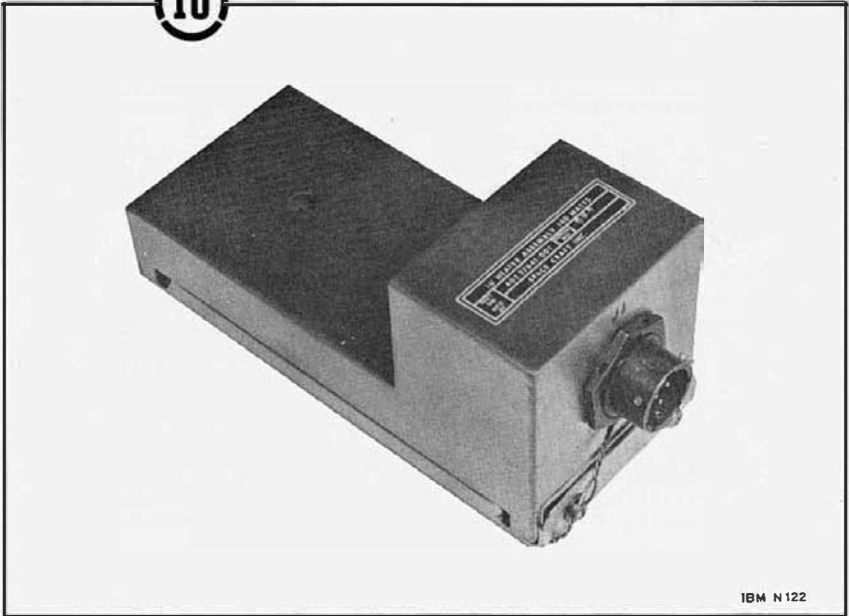

IBM N 122

To improve Environmental Control System heat balance, 140-watt Thermal Conditioning Panel Heaters are mounted directly to the Mounting and Thermal Conditioning Panels. The heaters are turned on at power transfer and remain on during flight. The quantity and location of the heaters vary from vehicle to vehicle.

Effectivity:	501-503
Specification No.	40Z39572
Figure 1 Location:	Panel 1 Callouts 20A and 20B, Panel 2 Callouts 15A, and 20C, Panel 17 Callouts 90C, and 90D, Panel 23 Callout 123B.

**ENVIRONMENTAL CONTROL SYSTEM**  
Thermal Radiation Shrouds

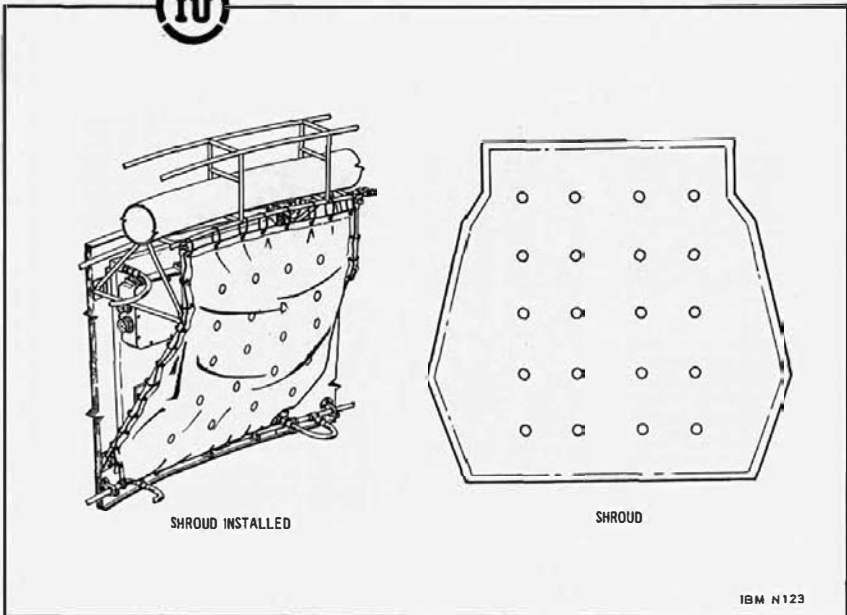

To improve Environmental Control System heat balance, Thermal Radiation Shrouds cover the inboard surfaces of the Thermal Conditioning Panels and Components. They are attached to the Cable Tray at the top, to the Cable Tray supports at the sides, and to the coolant return manifolds at the bottom. Air/ $\text{GN}_2$  purge gas from the Environmental Conditioning Duct is vented through open areas at the top and bottom of the shrouds and through holes in the shrouds.

The shrouds are fabricated from sheets of aluminized, low-thermal-emissivity mylar and bound with aluminum tape. The tape is used to reinforce the shrouds at the edges and around the vent holes. The shrouds are installed at KSC in the required locations for each vehicle effectivity.

In those locations where RF interference would result from the use of a shroud-type shield, a low-emissivity, pressure-sensitive tape is used. The tape is applied to accessible exposed surface areas of components and/or Thermal Conditioning Panels.

Effectivity: 204-207/501-503  
Specification No. 7915318 (Low-Emissivity Tape)  
Figure 1 Location: Not shown

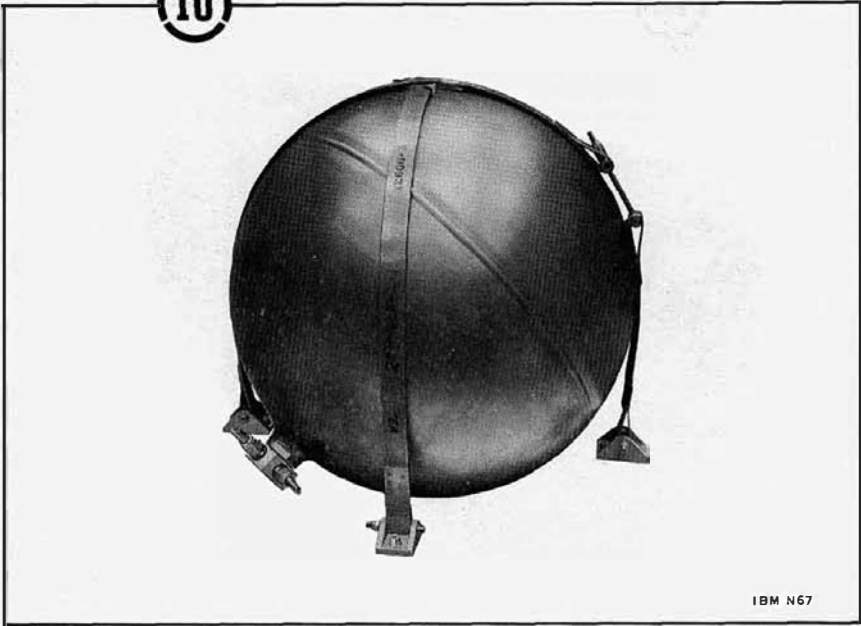

IBM N67

The Two-Cubic-Foot Sphere is used as a storage device for  $\text{GN}_2$  under pressure to pressurize the ST-124M-3 Inertial Platform Assembly gas bearing system.

Effectivity: All (Refer to note in Introduction)  
Specification No. 20Z32013  
Figure 1 Location: Panel 22 Callout 117

## ENVIRONMENTAL CONTROL SYSTEM

### Water Accumulator Assembly

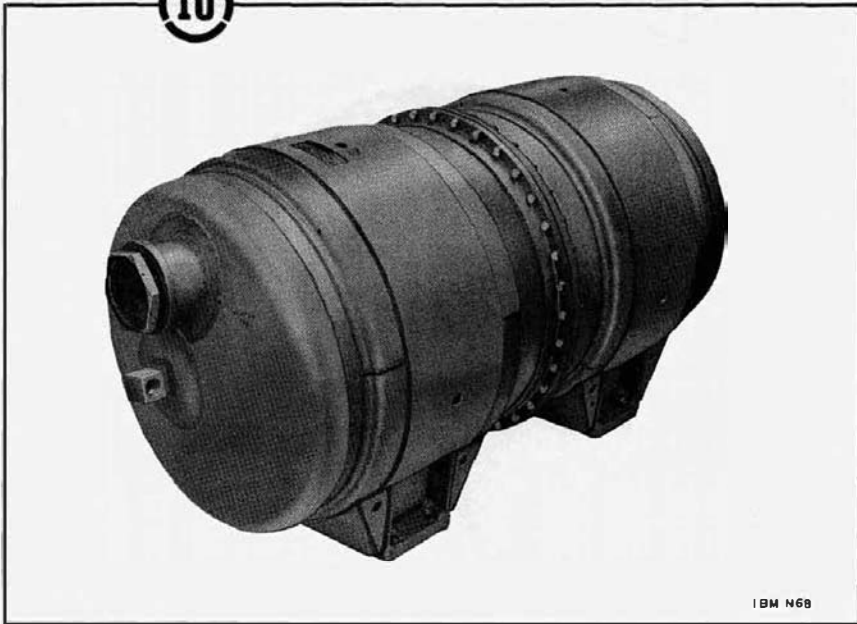

IBM N68

The Water Accumulator Assembly consists of a tank used to store water for use as a refrigerant to cool the methanol-water coolant as it flows through the sublimator, and an orifice assembly to regulate and vent the  $\text{GN}_2$  supply to the water accumulator. A rubber bladder within the accumulator separates the water and the pressurized  $\text{GN}_2$  used to force the water to the sublimator.

Effectivity:	All (Refer to note in Introduction)
Specification No.	20Z42122
Figure 1 Location:	Panel 3 Callout 27A Panel 6 Callout 37

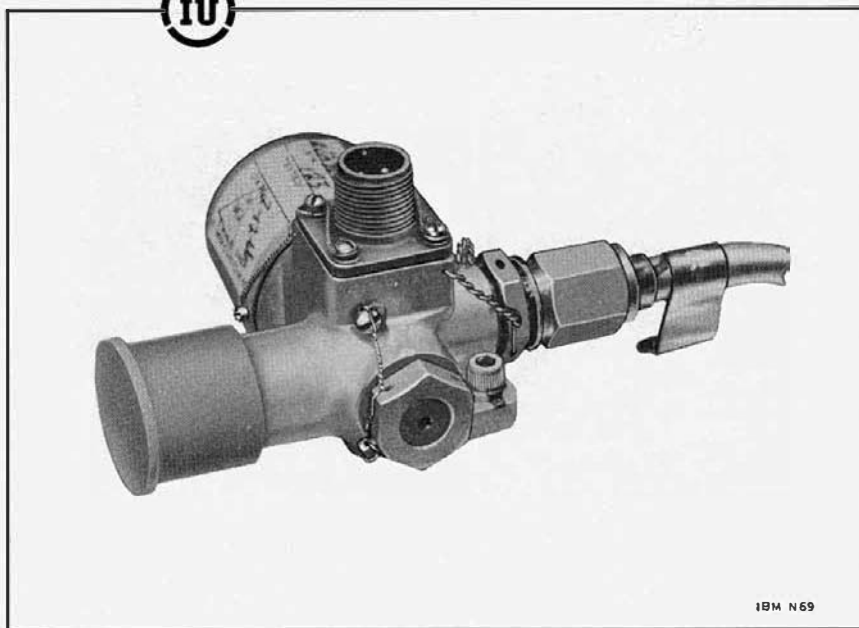

IBM N69

The Water Solenoid Valve is located in the water line between the Water Accumulator and the Heat Exchanger Assembly. The valve is held closed by a 28-volt signal from the LVDC until approximately 130 seconds after lift-off. At this time the 28-volt signal is removed, allowing the valve to transfer to its normally open position. When the valve has opened, water is able to flow from the Water Accumulator to the sublimator contained in the Heat Exchanger Assembly for subsequent cooling of the methanol-water solution in the thermal conditioning system.

Effectivity: All (Refer to note in Introduction)  
Specification No. 20Z42034  
Figure 1 Location: Panel 3 Callout 27B  
Panel 6 Callouts 36, 43, and 44C

# ENVIRONMENTAL CONTROL SYSTEM

## 50-Cubic-Inch Spheres/165-Cubic-Inch Sphere

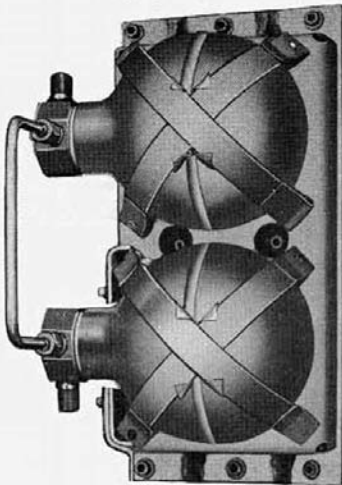

50-CUBIC-INCH  
SPHERES

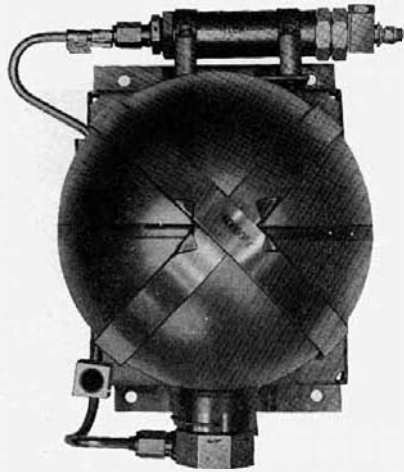

165-CUBIC-INCH  
SPHERE

IBM N56

The 50-Cubic-Inch Spheres and the 165-Cubic-Inch Sphere are used as storage devices for  $GN_2$  under pressure to maintain a pressure on the Water Accumulator and the Methanol-Water Accumulator.

Effectivity:	50-Cubic-Inch Spheres	201-205
	165-Cubic-Inch Sphere	206-212/501-515
Specification No.	50-Cubic-Inch Spheres	20Z42014
	165-Cubic-Inch Sphere	Not available
Figure 1 Location:	50-Cubic-Inch Spheres,	Panel 6 Callout 40
	165-Cubic-Inch Sphere,	Panel 6 Callout 44

**GUIDANCE AND  
CONTROL SYSTEM**



## GUIDANCE AND CONTROL SYSTEM

The Guidance and Control (G&C) System is an all-inertial system utilizing a stabilized platform for acceleration and attitude measurements. The Launch Vehicle Digital Computer (LVDC) is used for guidance computations and an analog computer, the Flight Control Computer, for the control functions. The guidance and control function is achieved by:

- A series of attitude, acceleration, velocity, and present-position determinations.
- The prediction and compilation of velocity corrections required to attain a desired space position and attitude.
- Generation of proper thrust and vehicle attitude control commands.

The G&C System issues commands to the attitude control devices of each stage during powered flight to guide the Saturn vehicle in accordance with a preprogrammed mission.

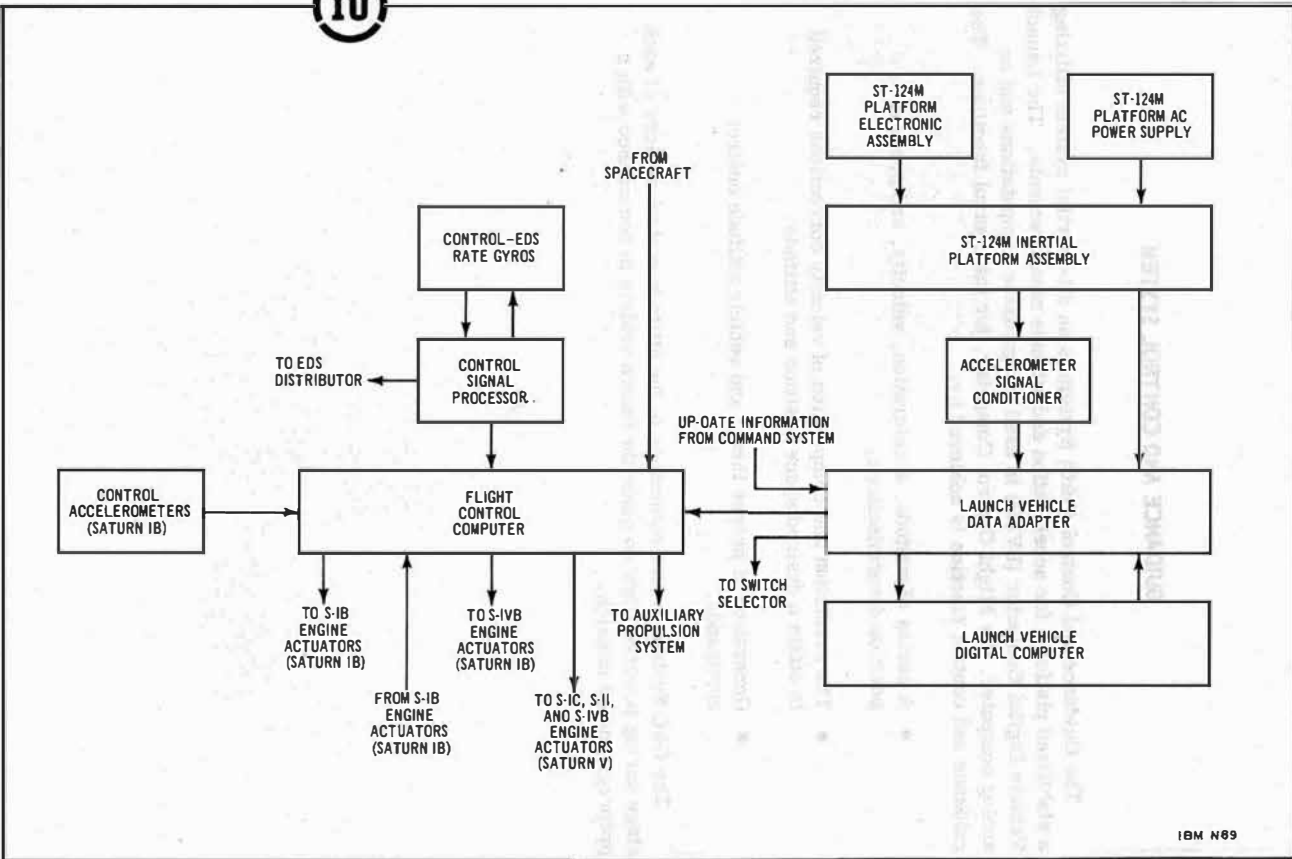

IBM N89

Guidance and Control System Block Diagram

IV

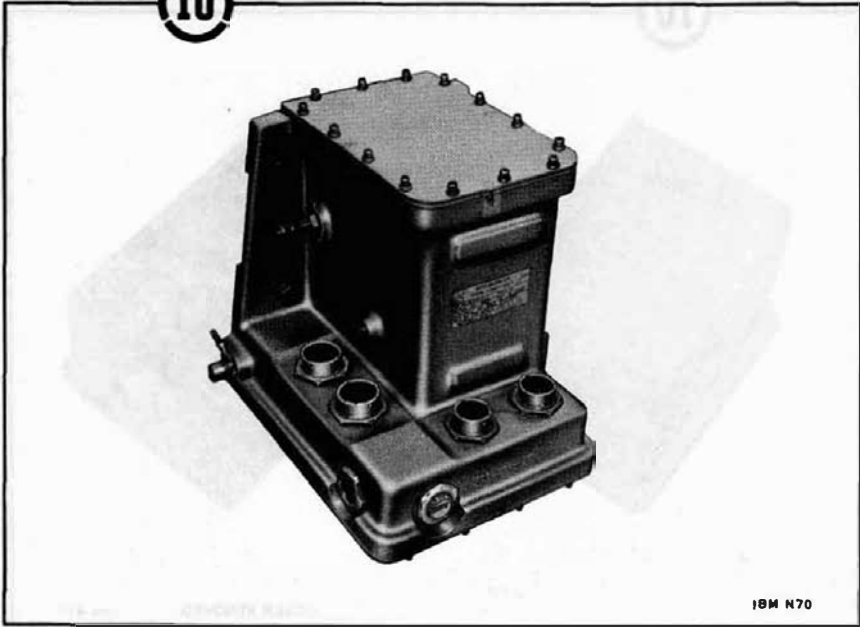

IBM N70

The Accelerometer Signal Conditioner will accept the velocity signals from the accelerometer optical encoders and shape them before they are passed on to the LVDA. The accelerometer telemetry velocity signals will also be conditioned by this component.

Effectivity: All (Refer to note in Introduction)  
Specification No. Not available  
Figure 1 Location: Panel 20 Callout 104

## GUIDANCE AND CONTROL SYSTEM

### Control Accelerometers

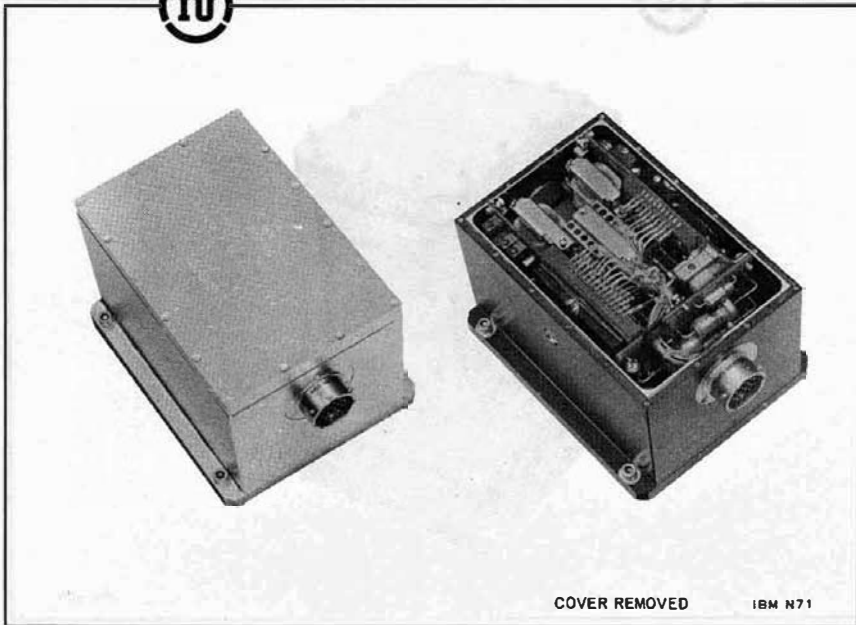

Two Control Accelerometers are provided in the IU, one mounted along the pitch axis and the other along the yaw axis. These Control Accelerometers provide analog signals of lateral acceleration to the Flight Control Computer for use during the controlled, attenuation+timer, programmed portion of flight. A Control Accelerometer consists of an accelerometer and the electronics necessary to process the output for transmission to the Flight Control Computer.

Effectivity:	201-212
Specification No.	6009085
Figure 1 Location:	Control Accelerometer (Pitch) Panel 2 Callout 15 Control Accelerometer (Yaw) Panel 21 Callout 112

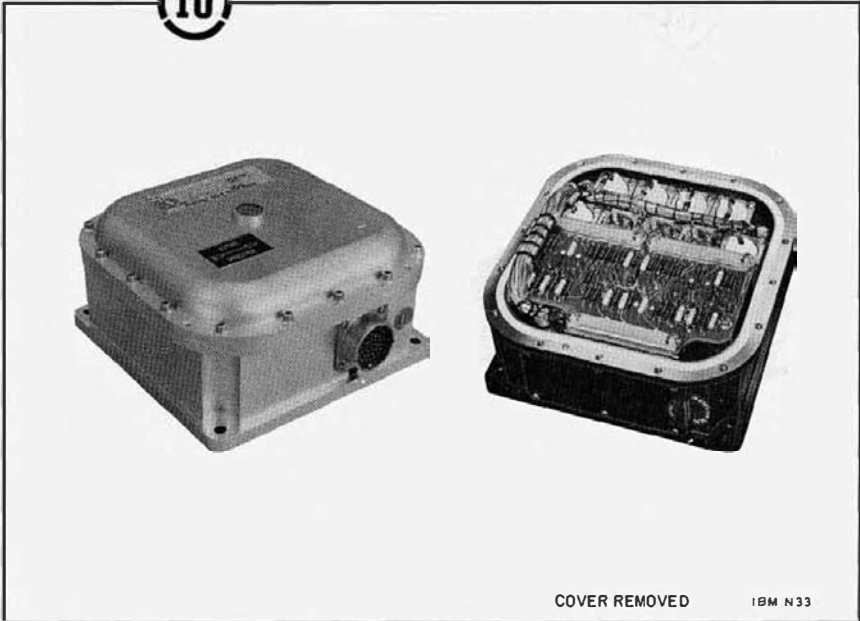

The Control-EDS Rate Gyros provide nine 400 Hz voltage output signals that are analogs of the rates of vehicle rotation about the yaw, pitch, and roll axes. These signals are sent to the Control Signal Processor, which provides outputs to the Flight Control Computer and the Emergency Detection System (EDS). The nine Control-EDS Rate Gyros are arranged in groups of three for triple redundancy. Each group, consisting of pitch, yaw, and roll rate gyros, is completely isolated electrically from the others.

Effectivity: All (Refer to note in Introduction)  
Specification No. 6009086  
Figure 1 Location: Panel 15 Callouts 82 and 90B

## GUIDANCE AND CONTROL SYSTEM

### Control Signal Processor



COVER REMOVED

IBM N34

The Control Signal Processor provides power to and receives inputs from the nine Control-EDS Rate Gyros. These inputs are processed by two separate sets of circuits. One set of circuits provide outputs to the Emergency Detection System Distributor, and the other set processes and provides rate signals to the Flight Control Computer.

Effectivity: All (Refer to note in Introduction)  
Specification No. 7907068  
Figure 1 Location: Panel 15 Callout 83

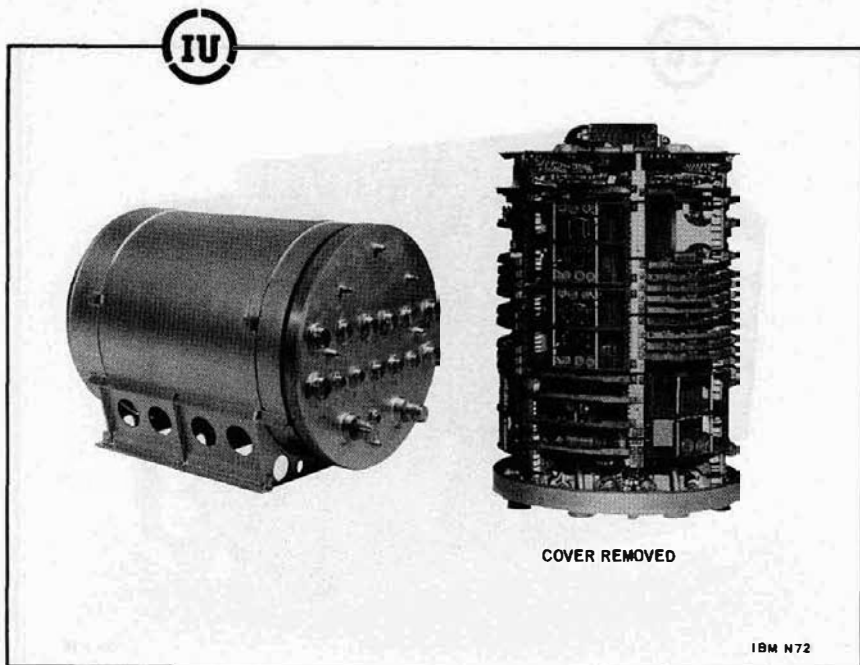

The Flight Control Computer is a dc analog instrument that receives attitude error signals from the LVDC and flight dynamic measurements from the accelerometers and the rate gyros. The Flight Control Computer performs the required operations to establish the allowable rate of attitude correction (based on predetermined limits of vehicle dynamics). The Flight Control Computer then directs the vehicle controls to correct any error in the vehicle flight attitude. Decisions by the Flight Control Computer will be based on the solution of flight control equations. Eight channels are used to accept lateral acceleration attitude error and attitude rate information during the flight of the S-IB, S-IC, and S-II Stages. Six additional channels accept the required parameters for controlling the flight of the S-IVB Stage.

Effectivity:	Flight Control Computer IB 201-212 Flight Control Computer V 501-515
Specification No.	Flight Control Computer IB, 201-204, 50M32550 Flight Control Computer IB, 205-212, 50Z32550 Flight Control Computer V, 501-503, 50M35300 Flight Control Computer V, 504-515, 50Z35300
Figure 1 Location:	Panel 16 Callout 86

# GUIDANCE AND CONTROL SYSTEM

## Launch Vehicle Data Adapter

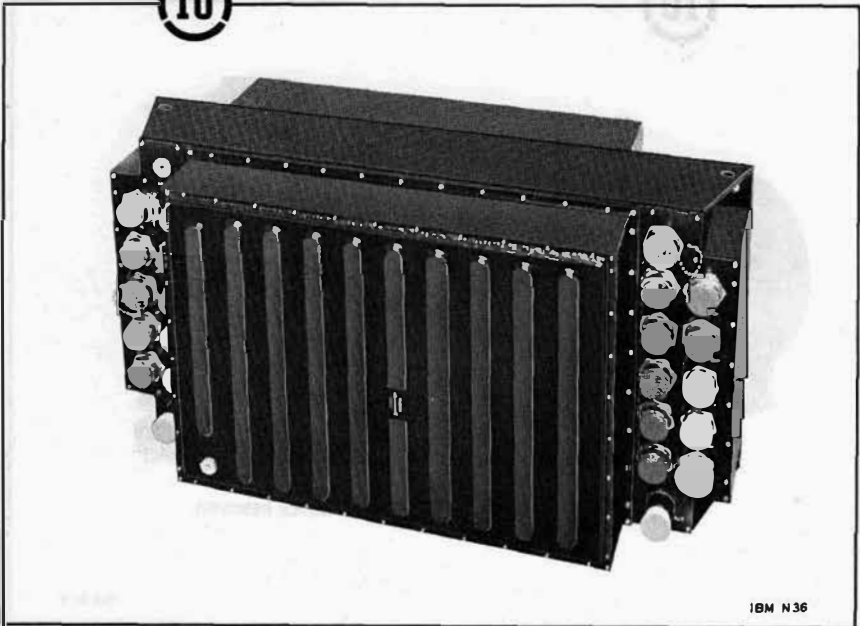

The Launch Vehicle Data Adapter (LVDA) is the input/output device for the Launch Vehicle Digital Computer (LVDC) and the central station for the signal flow in the Saturn Astrionics System. The LVDA transforms input and output signals to a form that is compatible with the characteristics of the receiving equipment, controls the data flow in the IU, performs certain simple computation and logical operations on data, and provides temporary storage of data.

- Effectivity: All (Refer to note in Introduction)
- Specification No. 6150000
- Figure 1 Location: Panel 19 Callout 96





The Launch Vehicle Digital Computer (LVDC) is a general purpose computer under control of a stored program. Data is processed serially in two arithmetic sections which can, if desired, operate concurrently. Addition, subtraction, and logical extractions are performed in one arithmetic section while multiplication and division are performed in the other. The principal storage device is a random access, ferrite-core memory with separate controls for data and instruction addressing. The memory can be operated in either simplex or duplex mode.

Effectivity: All (Refer to note in Introduction)  
Specification No. 6150001  
Figure 1 Location: Panel 19 Callout 101

## GUIDANCE AND CONTROL SYSTEM

### Retroreflector Assembly

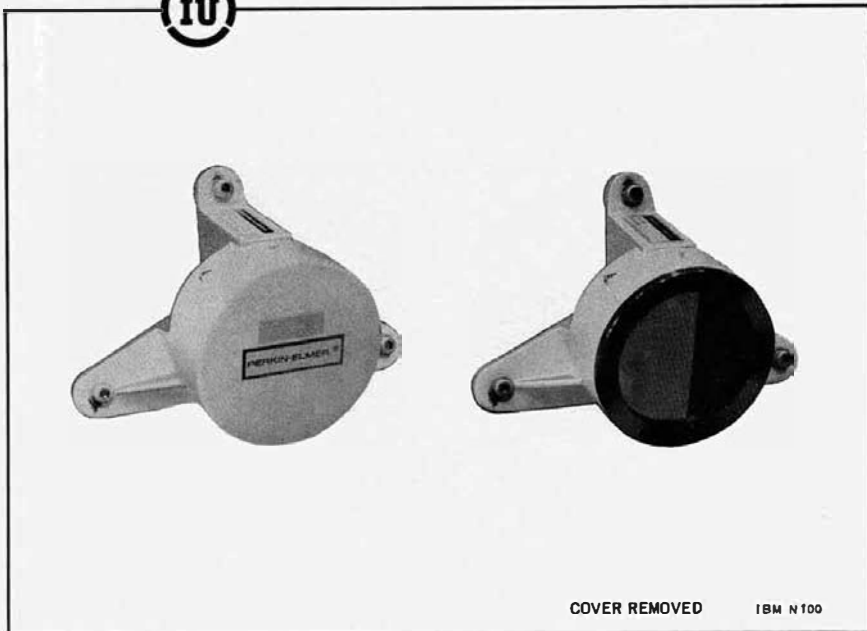

The Retroreflector Assembly is used as reference for a servo-system to position the penta mirror in the autocollimator theodolite located on the ground. The penta mirror, servosystem, and the Retroreflector Assembly provide the autocollimator theodolite with the capability of translatory tracking. At the vehicle elevation of the platform system, while the vehicle is resting on the pad, the autocollimator theodolite will compensate for a  $\pm 14$ -inch translation (sway) movement of the vehicle. Infrared energy is generated by the autocollimator theodolite and is reflected from the Retroreflector Assembly to detect deviation from the desired position of the vehicle. The retroreflector servo loop increases the effect of the autocollimator theodolite aperture from 8 inches to 32 inches at a rate of 32 inches/second.

Effectivity:	202-212/501-515
Specification No.	7907121
Location:	See Figure 2

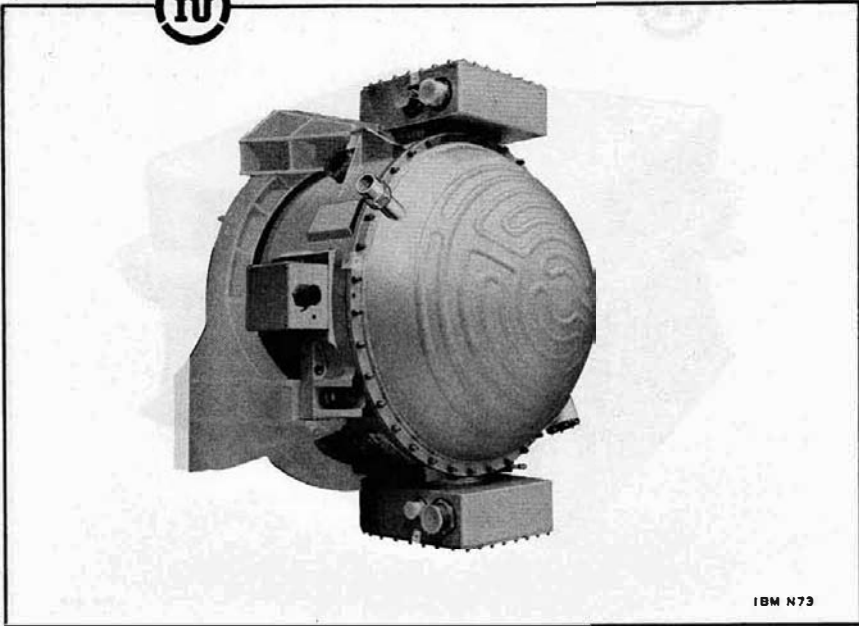

IBM N73

The ST-124M Inertial Platform Assembly measures vehicle acceleration and attitude with reference to each of the three axes of a space-fixed coordinate system and provides these measurements to the LVDA. The measurements are obtained from accelerometers mounted to the platform and are signal conditioned prior to being sent to the LVDA. The inertial platform system is capable of using either a three-gimbal (ST-124M-3) or a four-gimbal (ST-124M-4) configuration. The configuration selected will depend on individual mission requirements. The platform system is composed of the ST-124M Inertial Platform Assembly, the ST-124M Platform Electronic Assembly, the ST-124M Platform AC Power Supply, and the Accelerometer Signal Conditioner.

Effectivity:	All (Refer to note in Introduction)
Specification No.	Not available
Figure 1 Location:	Panel 21 Callout 114

GUIDANCE AND CONTROL SYSTEM  
ST-124M Platform AC Power Supply



The ST-124M Platform AC Power Supply furnishes the power required to run the gyro wheels, excitation for the platform gimbal synchros, frequency sources for the resolver chain references, and for gyro and accelerometer servosystems carrier. It is a solid-state, regulated, three-phase ac power supply. With an input voltage from 25 to 30 Vdc, it produces a three-phase sine wave output, which is fixed at 26 volts (rms) line to line, at a fixed frequency of  $400 \pm 0.01$  hertz.

- Effectivity: All (Refer to note in Introduction)
- Specification No. Not available
- Figure 1 Location: Panel 20 Callout 103



IBM N75

The ST-124M Platform Electronic Assembly contains the electronics, other than those located in the platform, required for the inertial gimbal and the accelerometer stabilization. Switching electronics for controlling platform system power and checkout functions are also located in the ST-124M Platform Electronic Assembly. The electronics are of the printed-circuit, modular constructed type and are fitted into the box that has an electrical connector for ease of assembly and maintenance.

**Effectivity:** All (Refer to note in Introduction)  
**Specification No.** Not available  
**Figure 1 Location:** Panel 20 Callout 95



## MEASURING AND TELEMETRY SYSTEM

The Measuring and Telemetry System measures physical quantities and electrical signals onboard the vehicle and transmits the data to ground stations. The complexity of the launch vehicle and its missions dictate a large number of measurements. The data transmitted by the Measuring and Telemetry System supply information for the following operations:

- Automatic preflight checkout of the vehicle
- Monitoring of vehicle performance during powered flight
- Postflight evaluation of vehicle performance
- Monitoring and checkout of the vehicle during orbital flight
- Verification of commands received in the vehicle from ground stations

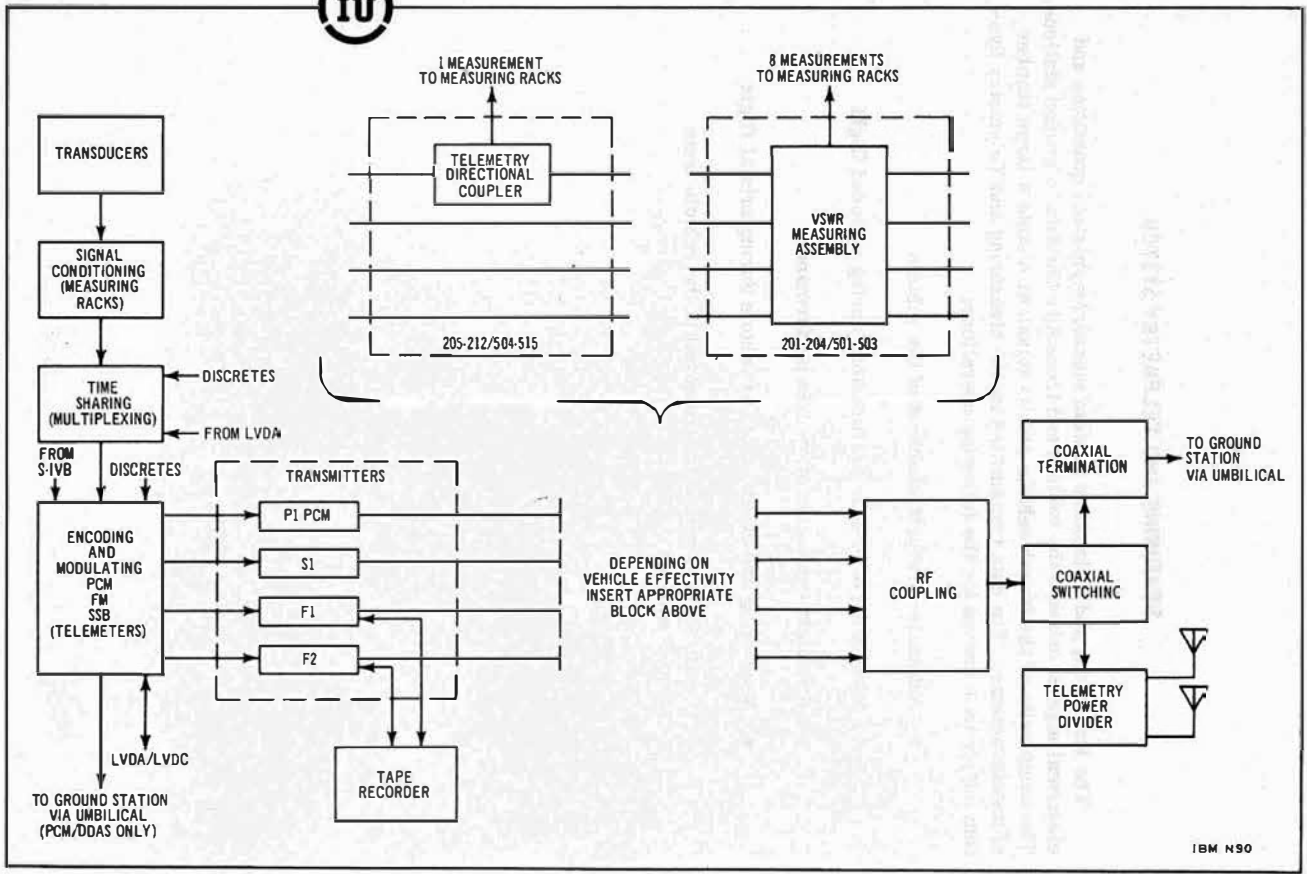

IBM NSO

VHF Measuring and Telemetry System Block Diagram





Changed 1 June 1967

UHF Measuring and Telemetry System Block Diagram

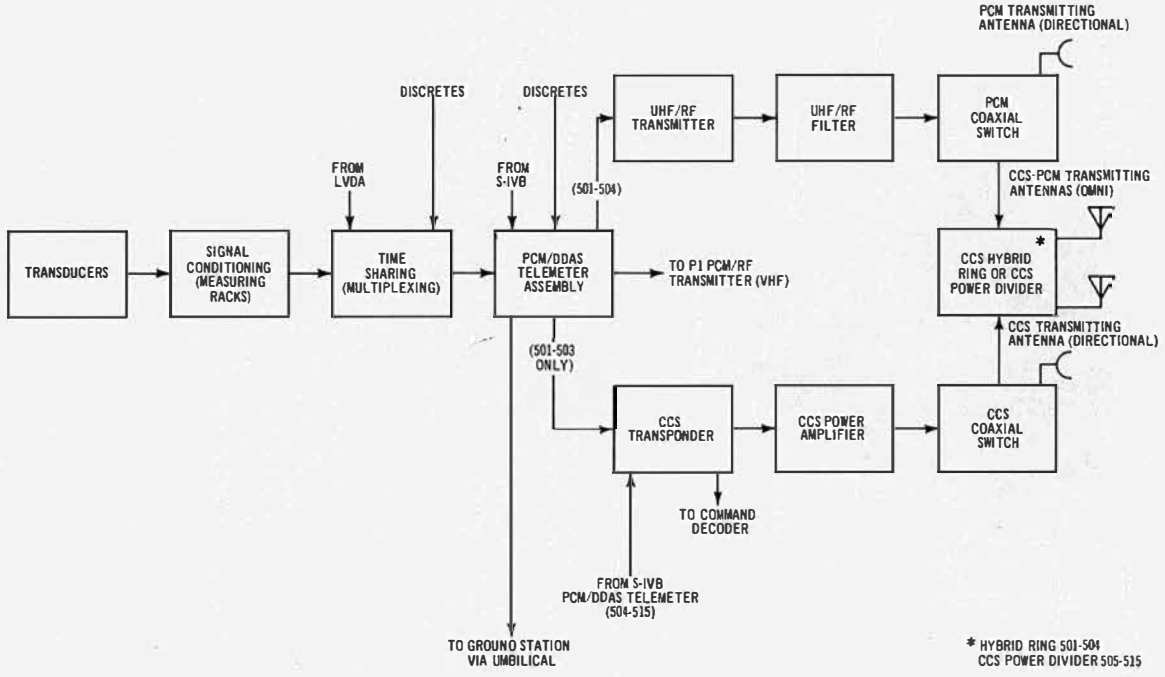

\* HYBRID RING 501-504  
CCS POWER DIVIDER 505-515

MEASURING AND TELEMETRY SYSTEM

## MEASURING SYSTEM

### Force Balance Accelerometers

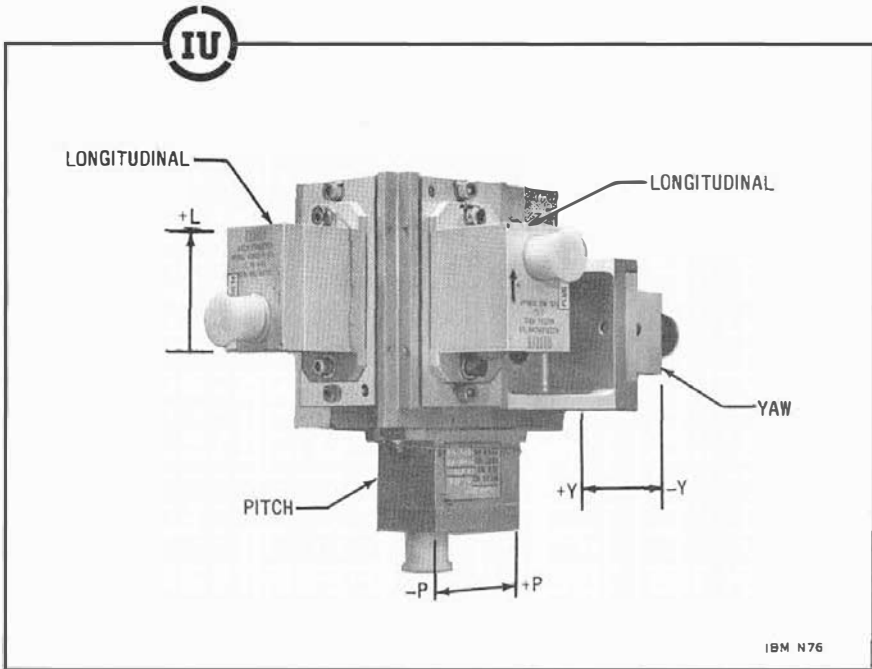

IBM N76

The accelerometers are used to measure longitudinal, yaw, and pitch g forces in the IU. Only the longitudinal accelerometers are used onboard the Saturn IB vehicles. The longitudinal, pitch, and yaw accelerometers are used onboard the Saturn V. The longitudinal accelerometer shown at the left in the above illustration measures zero to 4.5 g on all Saturn IB vehicles. However, the accelerometer in this position on Saturn V vehicles measures either zero to 4.5 g or zero to 5.0 g. The measurement signals are applied to Measuring Racks to be signal conditioned prior to transmission to the ground by the telemetry system.

Effectivity:	All (Refer to note in Introduction)
Specification No.	$\pm 0.5$ g 50M60277 201-203/501
	0-4.5 g 50M60267 201-203/501
	$\pm 0.5$ g 50Z60277 204-206/502
	0-4.5 g 50Z60267 204-206/502
	$\pm 0.5$ g 7907556 207/503-515
	0-5.0 g 7907542 503-515

Figure 1 Location: Panel 2) Callout 113

MEASURING SYSTEM  
Longitudinal Accelerometer Orbital LH<sub>2</sub> Venting  
Lateral Accelerometer Slosh, Pitch, and Yaw

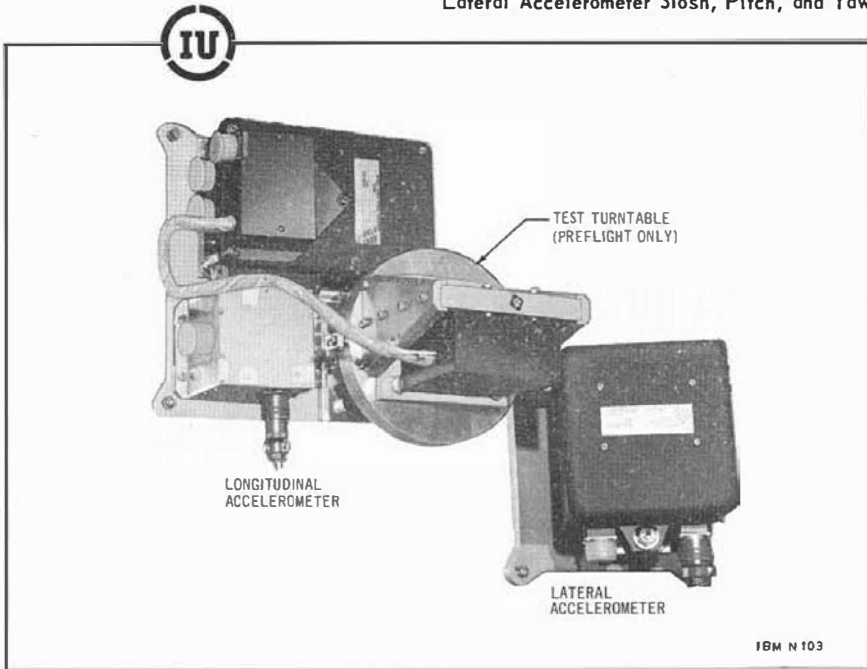

These two assemblies have been placed onboard S-IU-203 to monitor the effects of near-zero acceleration forces (low G experiment) on the IU and S-IVB Stage. The measurements taken will be those for longitudinal acceleration and the forces induced by propellant sloshing.

The Longitudinal Accelerometer consists of an accelerometer, counter, electronic box, and mounting plate. The accelerometer provides an analog output to the electronic box and the counter. The electronic box signal conditions the accelerometer analog output providing two 0 to 5-volt levels that indicate positive or negative acceleration. The counter converts the accelerometer analog output to a 14-bit digital output indicating a value from 0 to 0.0001 g. The output from the counter and either a positive or negative indication from the electronic box are required to provide a complete measurement.

The Lateral Accelerometer consists of an accelerometer and mounting plate. This accelerometer measures forces along the pitch and yaw axes and supplies two 0 to 5-volt outputs which indicate values from minus 0.0001 g to plus 0.0001 g for each axis.

The three measurements from the Longitudinal Accelerometer and the two measurements from the Lateral Accelerometer are applied directly to the PCM Telemeter Assembly for subsequent transmission to the ground.

Effectivity:	203
Specification No.	Longitudinal Accelerometer (Not available) Lateral Accelerometer 50M60332
Figure 1 Location:	Lateral Accelerometer, Panel 23 Callout 119 Longitudinal Accelerometer, Panel 23 Callout 120

## MEASURING SYSTEM

### Measuring Rack



Measuring Racks contain plug-in type signal conditioning modules that adapt the outputs of transducers and some electrical circuits to the electrical input requirements to the telemetry system. The quantity of racks and the quantity of modules within each rack vary from vehicle to vehicle dependent upon the mission requirements, however, each rack is capable of containing 20 signal conditioning modules. In addition to the signal conditioning modules, the racks contain one or two channel selector modules. The channel selector modules operate in conjunction with the Measuring Rack Selector to determine measuring equipment accuracy. The signal conditioning modules provide flexibility and ease of maintenance. They accept output signals from the transducers or electrical pickoffs and convert the signals to a proportional 0 to 5-volt range. Several types of signal conditioning modules are available for use in the racks; one type of module is illustrated on the following page. The types of signal conditioning modules used in the Measuring Racks are as follows:

- AC Amplifiers
- DC Amplifiers
- Servo-Accelerometers
- Frequency-to-DC Converters
- Frequency Measuring Adapters

Effectivity: All (Refer to note in Introduction)

Specification No. Not available

Figure 1 Location: Measuring Rack A401, Panels 2 and 1 Callouts 1 and 5, A402, Panels 1 and 9 Callouts 5 and 50, A403, Panels 11 and 15 Callouts 47, 85, and 90 A, A404, Panels 13 and 15 Callouts 68 and 84, A405, Panel 9 and 13 Callouts 50 and 68, A406, Panel 13 and 15 Callouts 78A, 85 and 90 A, A407, Panel 14 Callout 78, A408, Panel 14 Callout 77, A409, Panel 15 Callout 84, and A669, Panel 23 Callout 122

IBM N 105



BACK

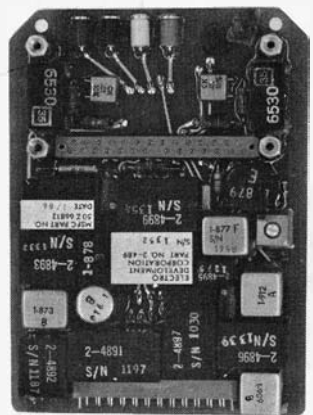

FRONT WITH RANGE  
CARD REMOVED

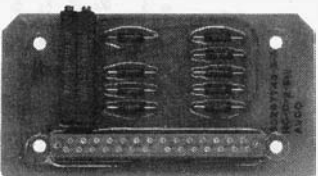

RANGE CARD

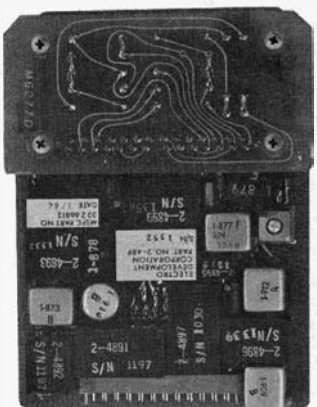

FRONT WITH RANGE  
CARD MOUNTED



Typical DC Amplifier Signal Conditioning Module

## MEASURING SYSTEM

### Measuring Rack Selector

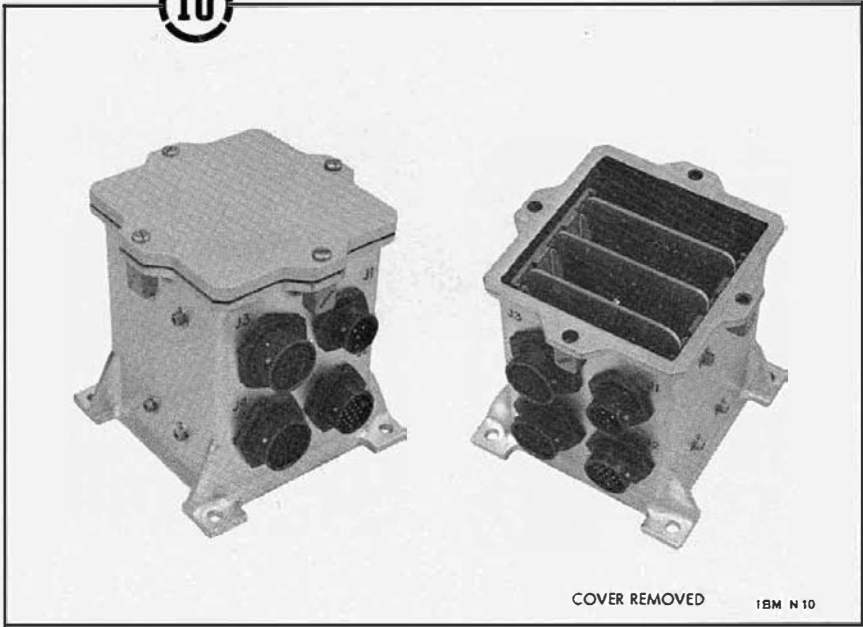

The Measuring Rack Selector operates in conjunction with the Ground Support Equipment (GSE) remote automatic calibration system to select a particular Measuring Rack, a channel or signal conditioning module within the Measuring Rack, and the high or low checkpoint for that particular channel. The purpose for the Measuring Rack Selector is to assist in determining the accuracy of the measuring equipment. Upon command for remote automatic calibration, the Measuring Rack Selector receives a binary coded input on 13 parallel input lines via the umbilical. These 13 inputs contain the information necessary to make the above mentioned selections. The Measuring Rack Selector houses the rack selector card, the mode converter card, and the sync generator card, all of which are solid-state logic circuits mounted on printed circuit boards.

Effectivity:	All (Refer to note in Introduction)
Specification No.	50M60077
Figure 1 Location:	Panel 1 Callout 12



VIBRATION ACCELEROMETER



TEMPERATURE GAGE



PRESSURE GAGE

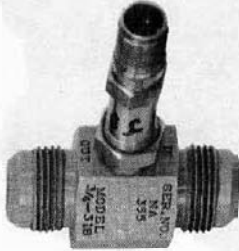

FLOWMETER

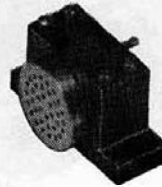

MICROPHONE

IBM H11

Transducers are electromechanical measuring instruments which contain sensitive devices for converting mechanical quantities into electrical signals. Evaluation of vehicle performance and inflight monitoring requires the measurement of a large variety of physical quantities onboard the vehicle. Therefore, many different types of transducer are used. Typical transducers are shown in the above illustration.

# TELEMETRY SYSTEM

## Coaxial Switch

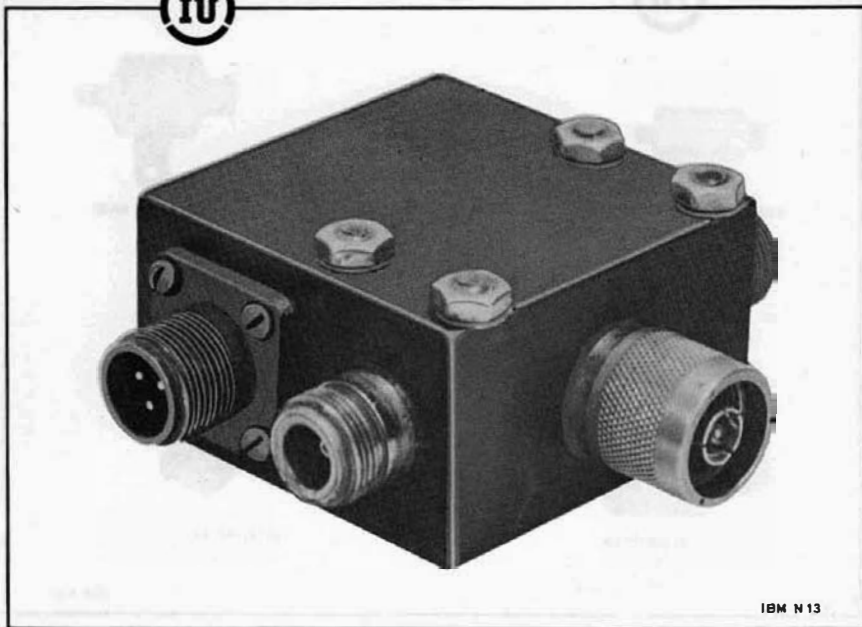

IBM N 13

The Coaxial Switch routes the telemetry transmitter signals either through the antennas or through the coaxial termination. The Coaxial Switch is a relay type and normally closed to the antenna position; therefore, after umbilical separation, it can only be in the antenna position.

Effectivity: All (Refer to note in Introduction)  
Specification No. 50Z60242  
Figure 1 Location: Panel 4 Callout 31



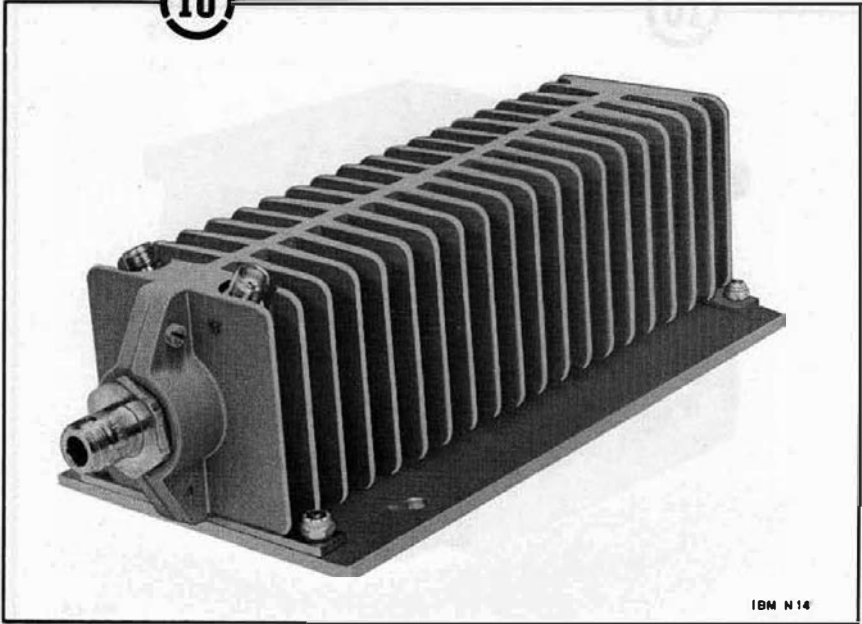

IBM N 14

The Coaxial Termination provides the load for closed-loop checkout of the telemetry system.

Effectivity: All (Refer to note in Introduction)  
Specification No. 50M60270  
Figure 1 Location: Panel 4 Callout 30

TELEMETRY SYSTEM  
DDAS/Computer Interface Unit



IBM N15

The DDAS/Computer Interface Unit (CIU) monitors the 10-bit parallel output of the PCM/DDAS Telemeter Assembly, and, when requested by the LVDA, transfers selected data to the LVDA.

Effectivity: 203-212/501-515  
Specification No. 50M60273  
Figure 1 Location: Panel 17 Callout 92

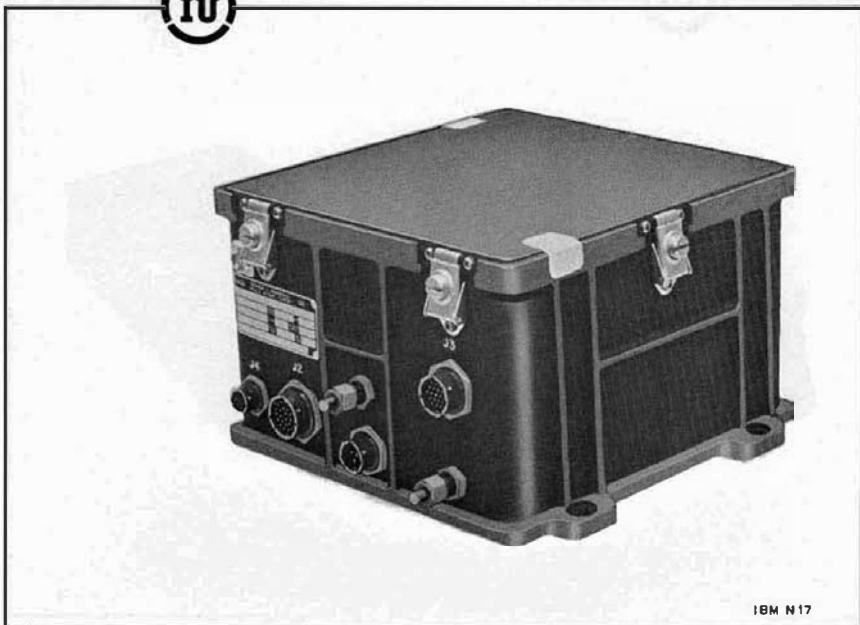

IBM N17

This F1 Telemeter Assembly is provided to convert analog measurement signals into proportional frequency-intelligent signals for subsequent modulation of an FM transmitter. All input signals must be preconditioned to a range of 0 to 5 Vdc. Input signals are applied to the telemeter assembly from transducers, Measuring Racks, Measuring Distributors, and multiplexers. The outputs of the telemeter assembly are furnished to the tape recorder as well as to an FM transmitter.

Effectivity: All (Refer to note in Introduction)  
Specification No. 50M60102  
Figure 1 Location: Panel 12 Callout 73

TELEMETRY SYSTEM  
F2 Telemeter Assembly

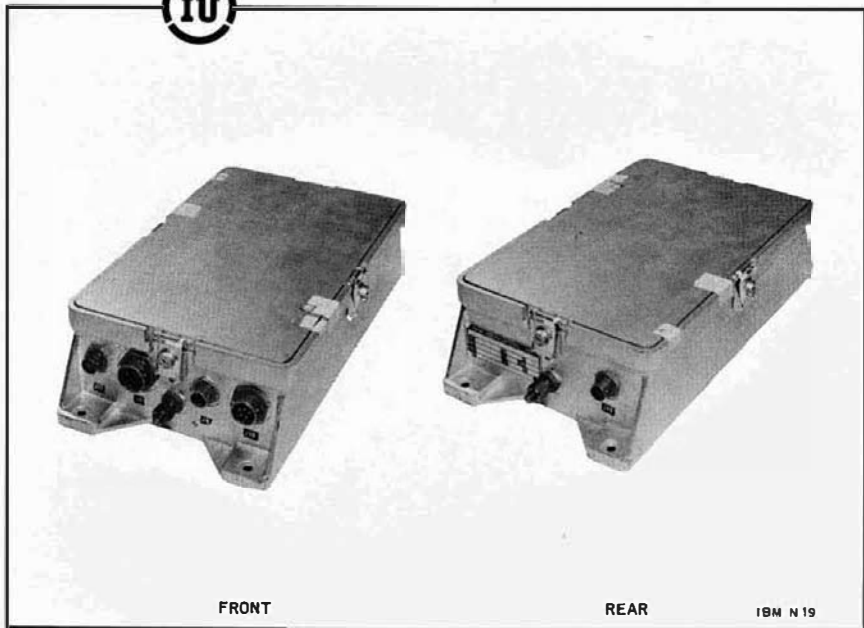

This F2 Telemeter Assembly is provided to convert analog measurement signals into proportional frequency-intelligent signals for subsequent modulation of an FM transmitter. All input signals must be preconditioned to a range of 0 to 5 Vdc. Input signals are applied to the telemeter assembly from transducers, Measuring Racks, Measuring Distributors, and multiplexers. The outputs of the telemeter assembly are furnished to the tape recorder as well as to an FM transmitter.

Effectivity: 201-204/501-503  
Specification No. 50M60101  
Figure 1 Location: Panel 10 Callout 56

TELEMETRY SYSTEM  
Multiplexer Assemblies  
CP1 and DP1

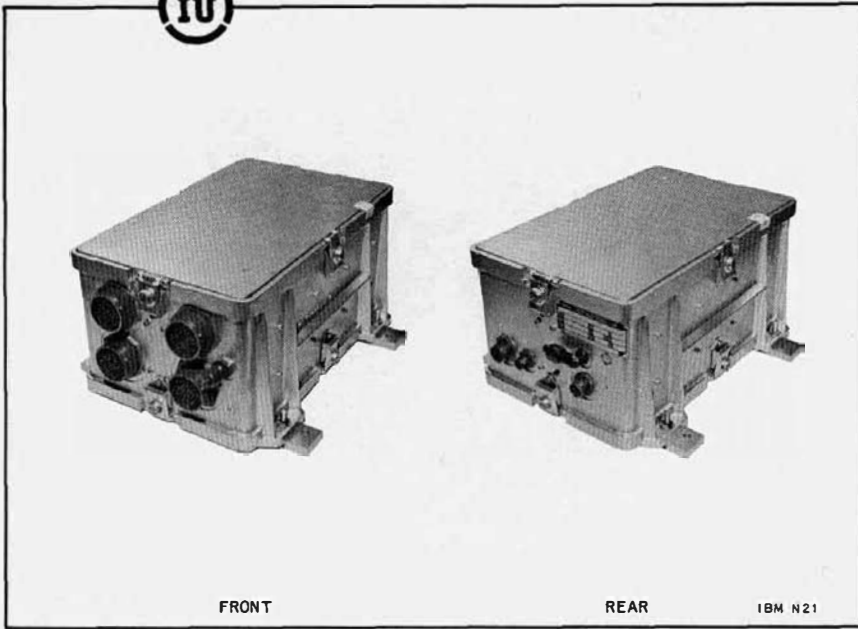

These Multiplexer Assemblies are Model 270 multiplexers. The Model 270 multiplexer is a two-stage multiplexer that sequentially monitors many input signals, and produces two parallel pulse trains, with each pulse a sample of an input signal. The input signals must be preconditioned to a range of 0 to 5 Vdc. The sampling rate is either 12 or 120 samples per second.

Effectivity: CP1, 201-212/501-515  
DP1, 201-212/501-515  
Specification No. 50M60061  
Figure 1 Location: CP1, Panels 9 and 10 Callouts 52 and 49  
DP1, Panels 9 and 10 Callouts 49 and 52

## TELEMETRY SYSTEM

### PCM Coaxial Switch

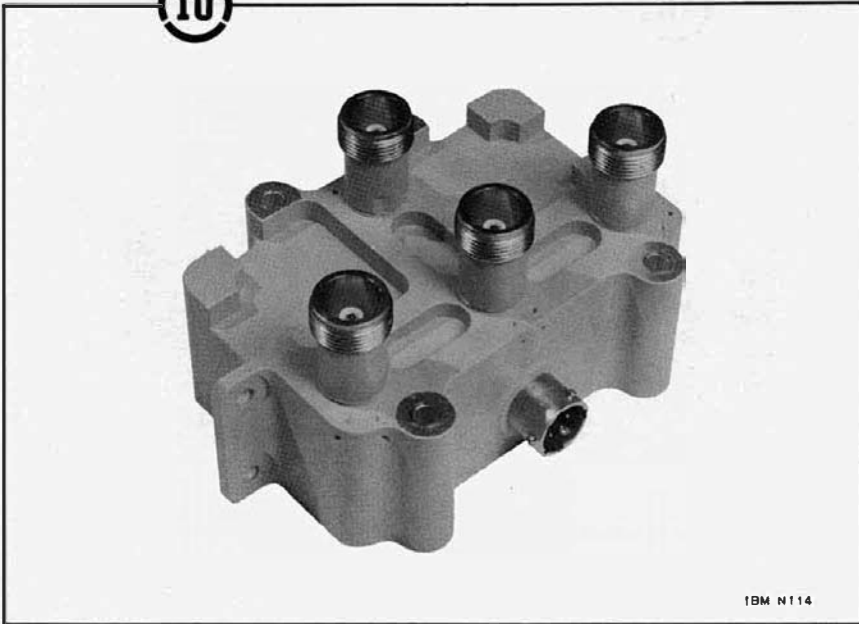

IBM N114

The PCM Coaxial Switch routes the UHF/RF Transmitter Assembly output signal to either the CCS Hybrid Ring or the PCM directional transmitting antenna. When in the normally closed position, the coaxial switch routes the signal to the hybrid ring which in turn applies the signal to the CCS/PCM omnidirectional antennas. The coaxial switch has two other positions; both positions route the signal to the PCM directional antenna. One of these positions applies the signal to the high gain input, while the other applies the signal to the low gain input of the PCM directional antenna. Inflight switching of the coaxial switch is controlled by the Switch Selector.

Effectivity:	501-504
Specification No.	Not available
Technical Manual:	None
Figure 1 Location:	Panel 24 Callout 24

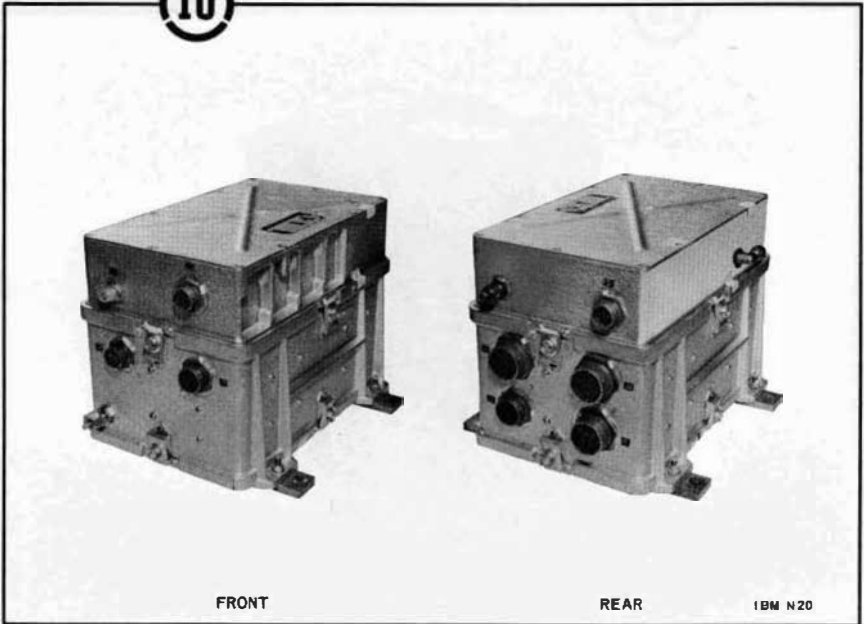

The Model 301 PCM/DDAS Telemeter Assembly is an encoder/multiplexer assembly that will accept and time-integrate Pulse Amplitude Modulation (PAM) analog signals, discrete signals, and digital signals into a single output. The single output is furnished to other components in three different forms. The PCM/DDAS Telemeter Assembly is also the key component for synchronization because it houses the master electronic clock. The three forms of the PCM/DDAS Telemeter Assembly output are:

- A serial, digital pulse train that is sent to an FM transmitter for broadcast to ground receiving stations.
- A succession of parallel, digital 10-bit groups that are sent to the DDAS/Computer Interface Unit (CIU) for transfer to the LVDC.
- A 600 kHz FM carrier, modulated by the serial pulse train, that is sent to the ground ESE via the umbilical.

Effectivity: All (Refer to note in Introduction)  
Specification No. 50M60067  
Figure 1 Location: Panel 12 Callout 70

TELEMETRY SYSTEM  
P1 PCM/RF Transmitter Assembly

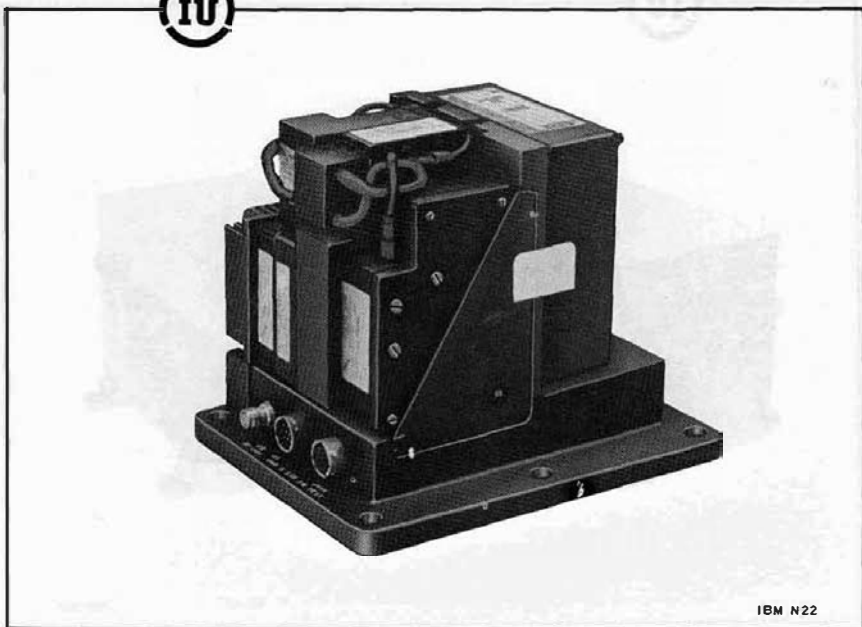

IBM N22

The P1 PCM/RF Transmitter Assembly Model CT-19B uses the PCM pulse train from the PCM/DDAS Telemeter Assembly as modulation for a VHF carrier. The unit uses a combination of solid-state devices and vacuum tubes to transmit through the RF transmission components.

Effectivity: 201-202  
Specification No. 50M60029  
Figure 1 Location: Panel 13 Callout 74



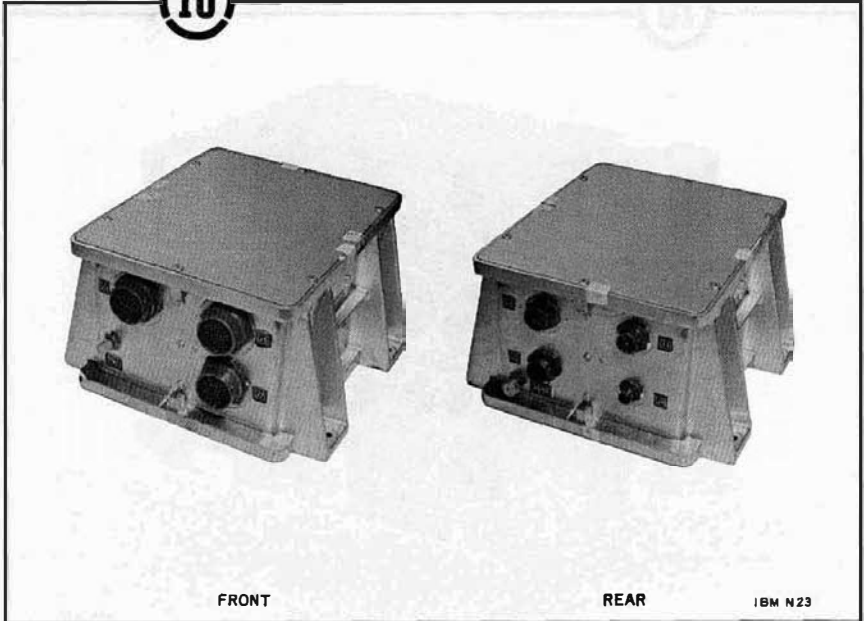

The Model 410 Remote Digital Multiplexers (RDM) accept up to 100 bits of digital data, temporarily stores them as ten 10-bit words, and sends the words in a repeating sequence to the PCM/DDAS Telemeter Assembly. The units are pre-programmed to determine the order of monitoring the inputs and the order of sending the words to the PCM/DDAS Telemeter Assembly. The units are synchronized with the PCM/DDAS Telemeter Assembly to cause the output words to appear at the instant the PCM/DDAS Telemeter Assembly is programmed to accept them.

Effectivity:	All (Refer to note in Introduction)
Specification No.	50M60274
Figure 1 Location:	Remote Digital Multiplexer, Panel 18 Callout 100 Remote Digital Multiplexer (J), Panels 11 and 17 Callouts 59 and 91 Remote Digital Multiplexer (K), Panel 18 Callouts 100 and 106

TELEMETRY SYSTEM  
Remote Digital Submultiplexer

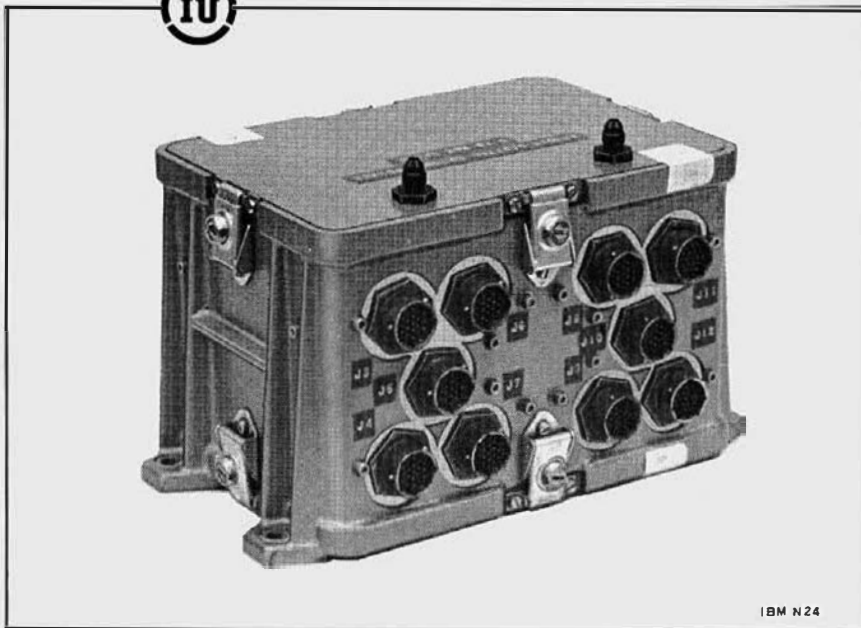

The Remote Digital Submultiplexer (RDSM) accepts up to 100 discrete measurements and gates them in groups to the PCM/DDAS Telemeter Assembly. Commands from the PCM/DDAS Telemeter Assembly determine the order in which the groups are sent out, and the RDSM is synchronized with the PCM/DDAS Telemeter Assembly to ensure that the output groups appear at the instant the PCM/DDAS Telemeter Assembly is programmed to accept them.

Effectivity: 201-204  
Specification No. 50M12213  
Figure 1 Location: Panel 17 Callout 81

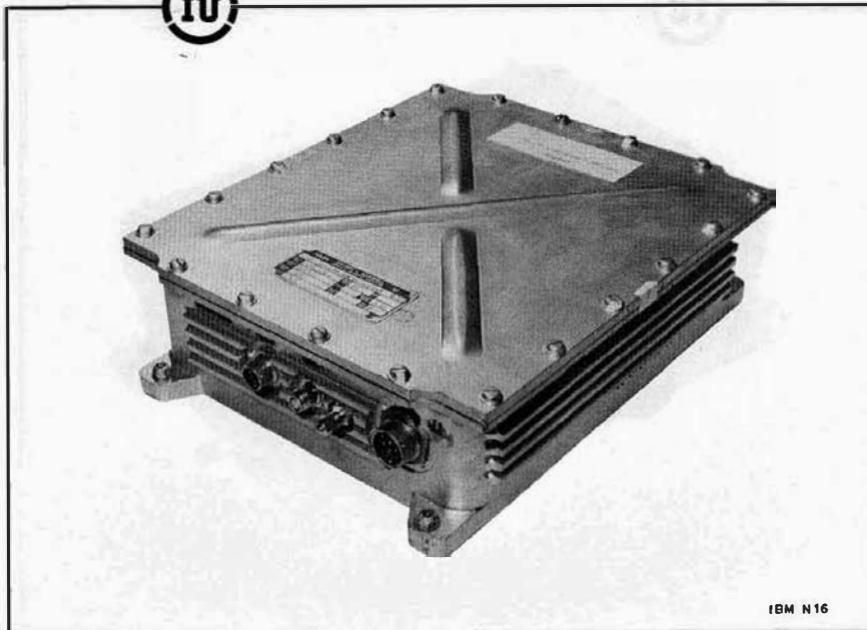

IBM N16

The RF Transmitter Assemblies accept frequency-intelligent data from their respective Telemeter Assemblies and frequency modulate a VHF carrier with the data. The transmitters contain dc-to-dc converter circuitry to produce regulated power for their transmitter and power amplifier subassemblies. The incoming signal is first applied to a signal adapter and then to the solid-state transmitter subassembly. The output carrier from the transmitter subassembly is then processed through the power amplifier and low-pass output filter.

Effectivity:	F1 Mod I, 201-204 F1 Mod II, 205-212/501-515 F2 Mod I, 201-204 F2 Mod II, 501-503 P1 PCM Mod II, 203-212/501-515 S1 Mod I, 201-204 S1 Mod II, 501-503
Specification No.	F1, F2, and S1 Mod I 50M60071 F1, F2, and S1 Mod II 50M60085 P1 PCM Mod II 50M60263
Figure 1 Location:	F1, Panel 12 Callout 69 F2, Panel 9 Callout 54 P1 PCM, Panels 11 and 13 Callouts 62 and 79 S1, Panel 11 Callout 57

# TELEMETRY SYSTEM

## Slow Speed Multiplexer Assembly

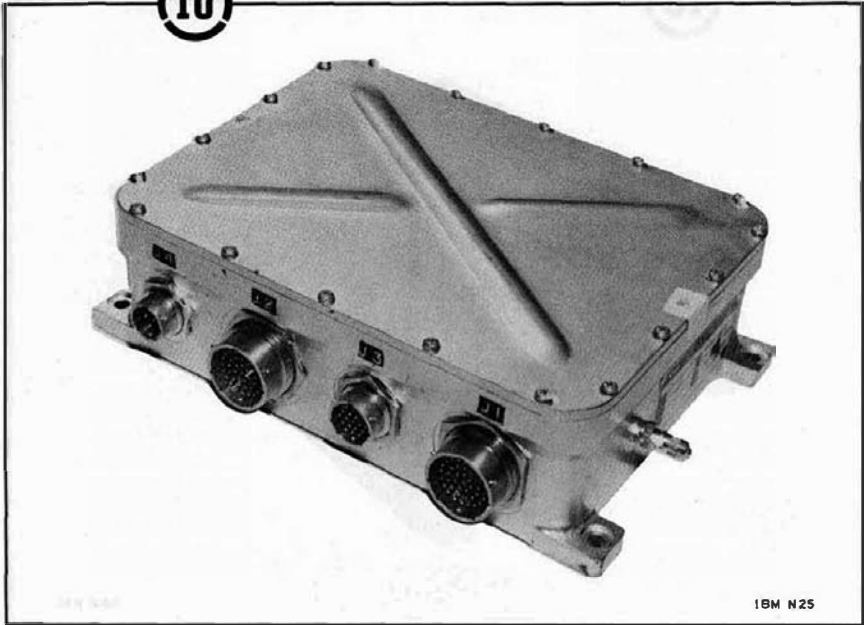

The purpose of the Model 245 Slow Speed Multiplexer Assembly is to time-share up to 80 high-frequency measurements to increase the measurement capacity of the telemeter equipment. The inputs (mainly vibration measurements) may come from transducers, signal conditioners, or other end items. These inputs are multiplexed into 16 output channels which may be sent to either the F1, F2, or S1 Telemeter Assemblies.

Effectivity: 201-204/501-503

Specification No. 50M60023

Figure 1 Location: Panel 11 Callout 45

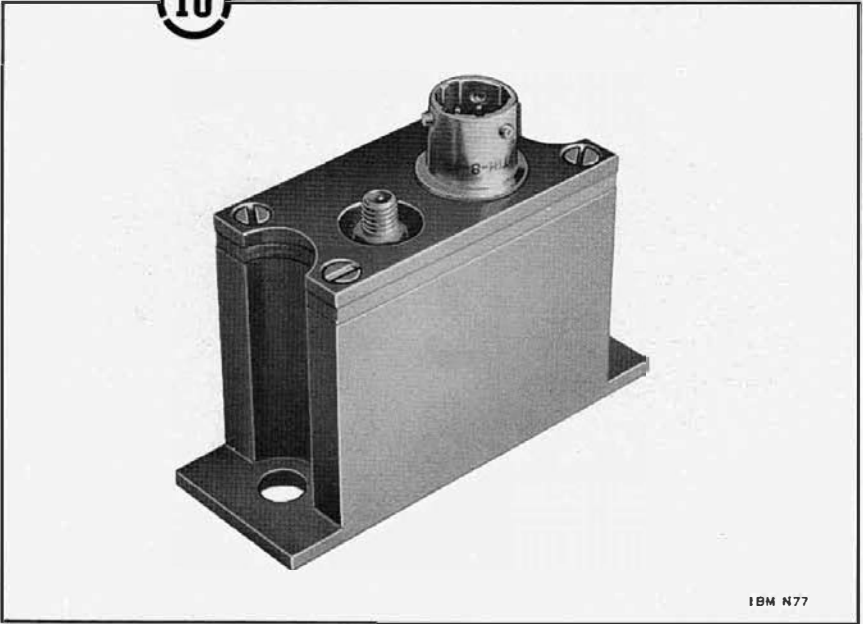

The Source Follower electrically isolates and increases the current of the microphone (acoustic transducer) output. The Source Follower receives operating power from a Measuring Rack, and its output is routed to an ac amplifier signal conditioning module. Prior to launch, the Source Follower and subsequent components can be calibrated by application of a 400 Hz calibration signal.

Effectivity: 201-204/501-503  
Specification No. Not available  
Figure 1 Location: Panel 1 Callout 13

**TELEMETRY SYSTEM**  
**S1 Telemeter Assembly**

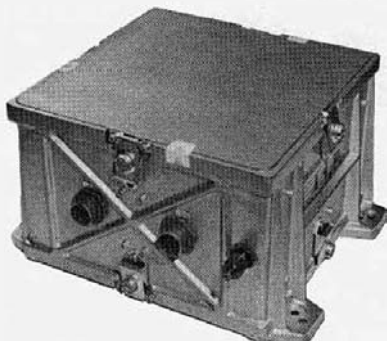

SATURN IB

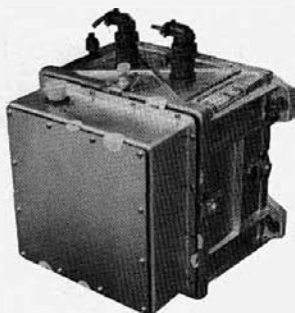

SATURN V

IBM N26

The S1 Telemeter Assembly provides 17 modulation channels of wide-frequency-band data to an FM transmitter. Measurement data is sent through 15 of these bands while the other 2 bands are used for synchronizing signals. The channels are spaced in a manner to produce a nominal bandwidth to the transmitter while retaining high accuracy. The single sideband modulation method is used in the telemeter assembly to improve the measurement handling capacity of the transmitter.

A top deck assembly is added to the S1 Telemeter Assembly onboard Saturn V vehicles. This top deck assembly contains a dc-to-dc converter for isolation of power and a mixer amplifier for output isolation and impedance matching.

Effectivity: 201-204/501-503  
Specification No. 50M60002  
Figure 1 Location: Panel 11 Callout 58



IBM N 12

The Tape Recorder records and stores, for future transmission, that information which would otherwise be lost because of atmospheric ionization during retro-rocket fire. The recorder is operated on command from the Guidance and Control System to record outputs of F1 and F2 Telemeter Assemblies on the two tracks of this magnetic recorder.

Effectivity: 201-204/501-503  
Specification No. 50M60016  
Figure 1 Location: Panel 11 Callout 46

## TELEMETRY SYSTEM

Telemetry Calibrator

Telemetry Calibrator Power and Control Assembly



The Telemetry Calibrator and the Telemetry Calibrator Power and Control Assembly function together to furnish control and calibration inputs to the telemetry components. The calibrator selects the calibration signal level and the component to be calibrated. The power and control assembly furnishes regulated power to the calibrator and also serves as an interface unit, routing and isolating all signals to and from the calibrator. Telemetry calibration is used during flight and prelaunch checkout.

Effectivity: All (Refer to note in Introduction)  
Specification No. TM Calibrator 50M60026  
TM Calibrator Power and Control Assembly  
50M60284

Figure 1 Location: Telemetry Calibrator, Panels 11 and 13  
Callouts 64 and 76  
Telemetry Calibrator Power and Control Assembly,  
Panels 11 and 13 Callouts 63 and 75



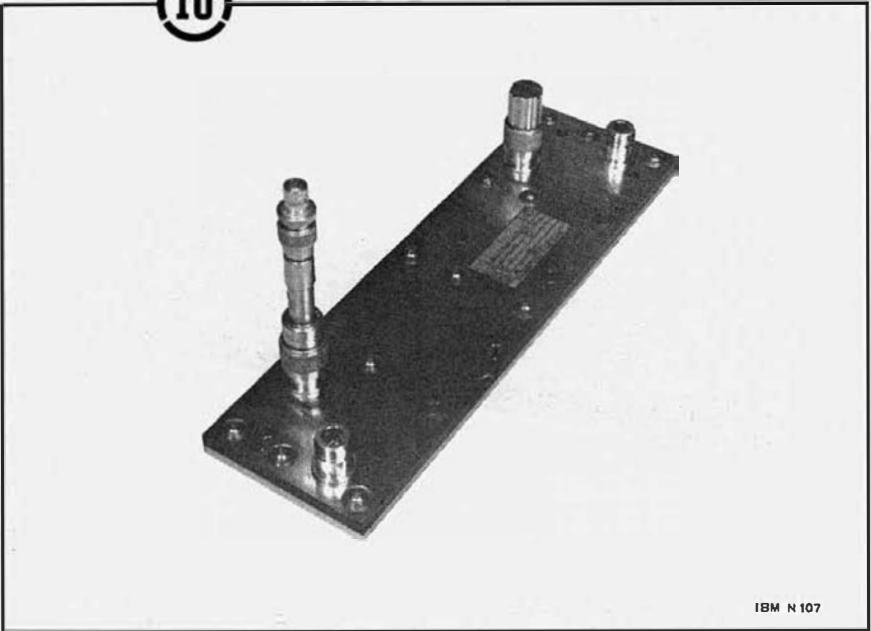

IBM N 107

The Telemetry Directional Coupler contains a coupler assembly which measures the transmitted power of the P1 PCM/RF Transmitter Assembly. The output signal from the coupler is low level dc and is fed to a Measuring Rack dc amplifier signal conditioning module.

Effectivity: 205-212/504-515  
Specification No. Mod 226, 7907499  
Figure 1 Location: Panel 10 Callout 65

**TELEMETRY SYSTEM**  
**Telemetry Power Divider**

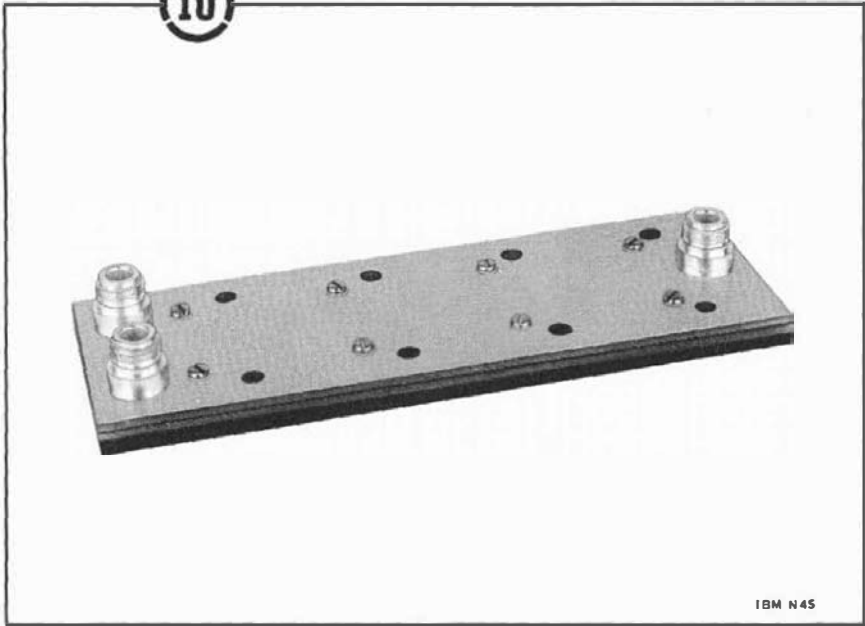

IBM N45

The Telemetry Power Divider routes and equally divides the composite carrier signal from the Coaxial Switch to the two telemetry antennas. The power divider also provides impedance matching.

Effectivity: All (Refer to note in Introduction)  
Specification No. 50M60256  
Figure 1 Location: Panel 4 Callout 29

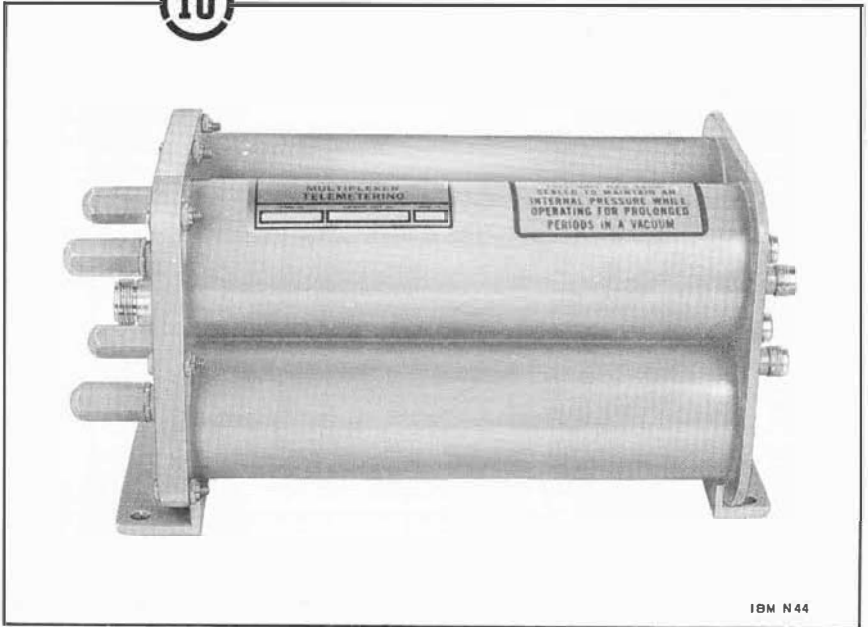

IBN N44

The Telemetry RF Coupler uses tuned cavities to selectively pass signals from the telemetry RF transmitters to the Coaxial Switch. Each carrier input passes through a resonant cavity that is tuned to  $1/4$  wavelength of the carrier center frequency. The carriers are then capacitively coupled together and routed to the Coaxial Switch. Since each cavity is tuned to a different center frequency, only the selected carrier frequency may pass.

Effectivity: All (Refer to note in Introduction)  
Specification No. 50M60278  
Figure 1 Location: Panel 9 Callout 53

# TELEMETRY SYSTEM

## UHF/RF Filter

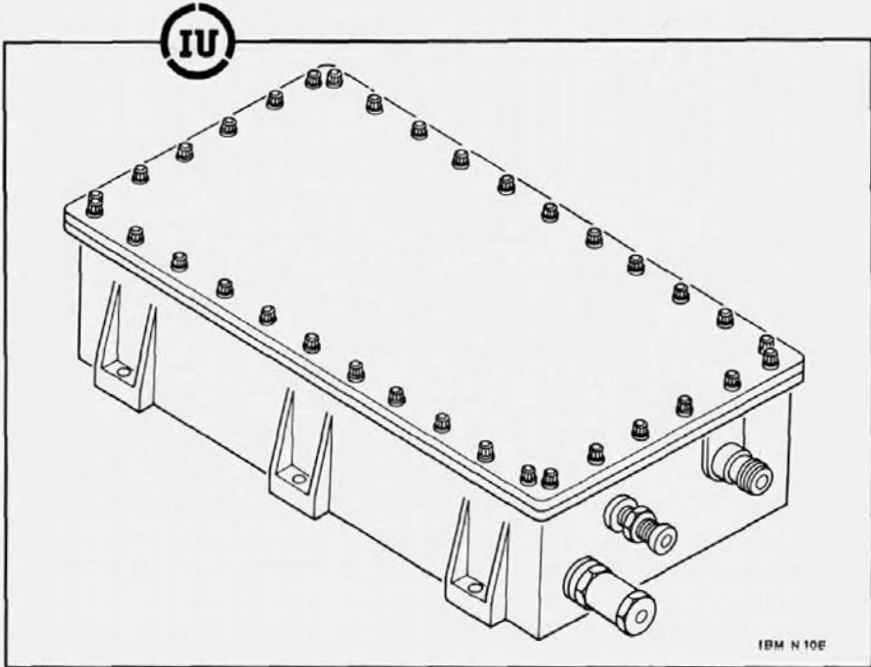

The UHF/RF Filter serves as a bandpass filter for the output of the UHF/RF Transmitter Assembly. The filter ensures that noise generated by the UHF/RF Transmitter is not radiated by the UHF transmitting antennas (PCM directional and the CCS/PCM omnidirection) thereby overlapping the signal received by the CCS receiving antennas. The RF noise spectrum of the UHF Transmitter overlaps the signal received by the CCS Transponder. The UHF/RF Filter prevents interference problems.

Effectivity:	503
Specification No.	Not available
Figure 1 Location:	Panel 23 Callout 123

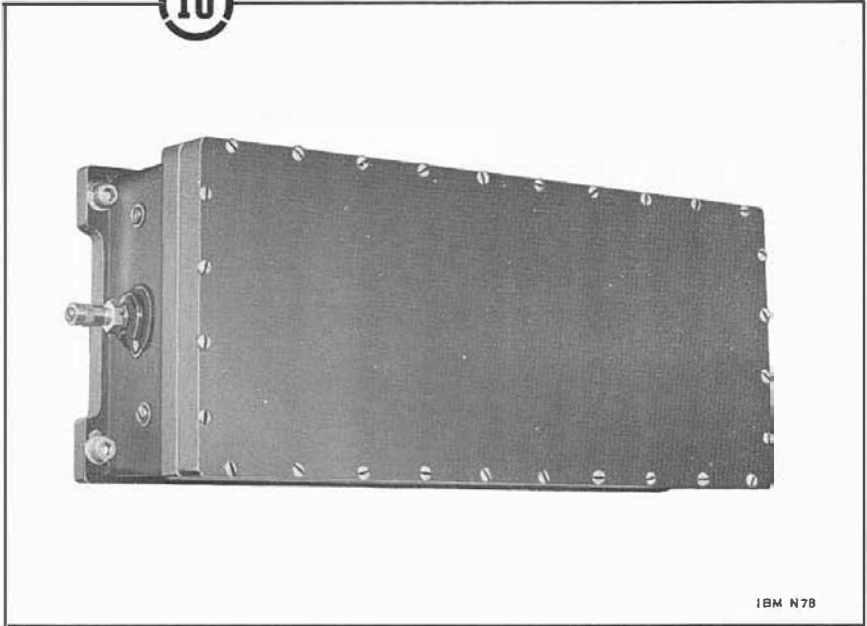

IBM N78

The UHF/RF Transmitter Assembly uses the PCM pulse train from the PCM/DDAS Telemeter Assembly as modulation for a UHF carrier. The UHF/RF Transmitter Assembly operates in parallel with the P1 PCM/RF Transmitter Assembly. The unit uses a combination of solid-state devices and vacuum tubes to transmit through the RF transmission components.

Effectivity:	501-504
Specification No.	Not available
Figure 1 Location:	Panel 24 Callout 23

TELEMETRY SYSTEM  
VSWR Measuring Assembly

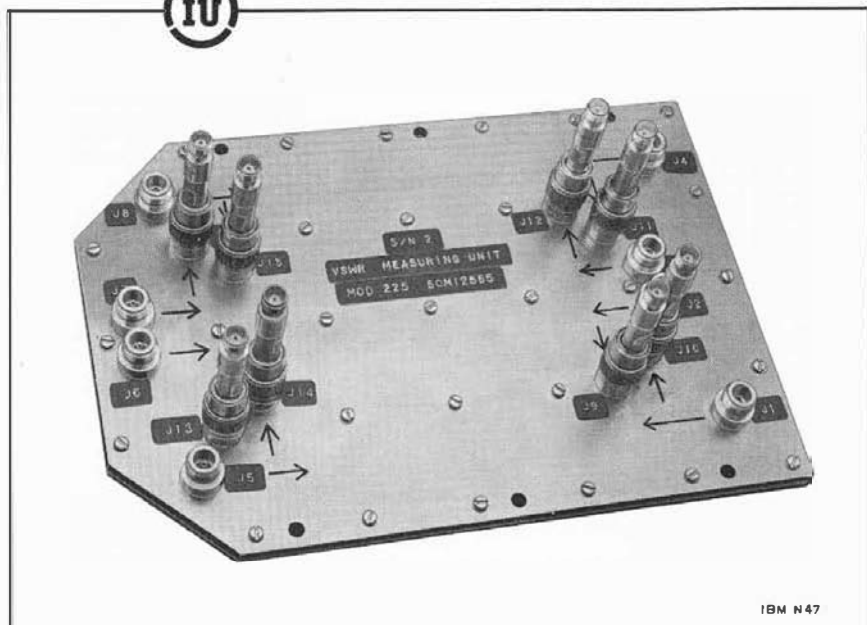

IBM N47

The VSWR Measuring Assembly contains four coupler assemblies, each of which measures the transmitted and reflected power of a telemetry transmitter. Each of the eight output signals from the assembly is low-level dc and is fed to a dc amplifier signal conditioning module.

Effectivity:            Model 220 201-202  
                              Model 225 203-204/501-503  
Specification No.      50M60259  
Figure 1 Location:    Panel 10 Callout 55

**RADIO FREQUENCY  
SYSTEM**

## **RADIO FREQUENCY SYSTEM**

The Radio Frequency (RF) System is available as required for various missions to provide tracking and command. The onboard equipment is connected through RF links with the corresponding ground equipment. The RF System provides a means of receiving digital data or commands from a ground station as well as tracking the vehicle. The principal functions of the RF System are:

- Tracking of the vehicle to supply range safety parameters.
- Tracking of the vehicle to supply orbital plotting information and orbital tracking.
- Providing a path for supplying data and commands from ground equipment to the onboard Guidance and Control System.



# RADIO FREQUENCY SYSTEM

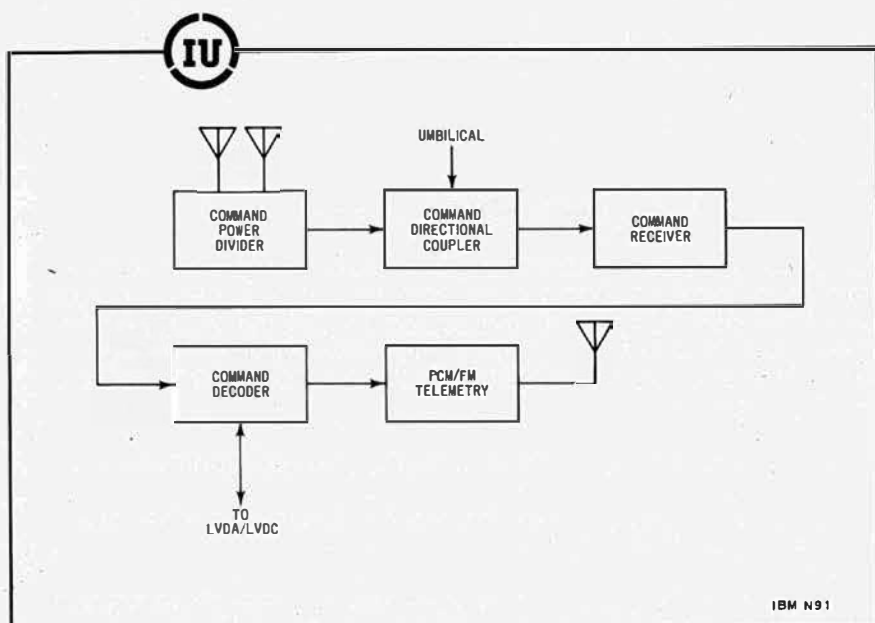

Saturn IB Instrument Unit Command System Block Diagram

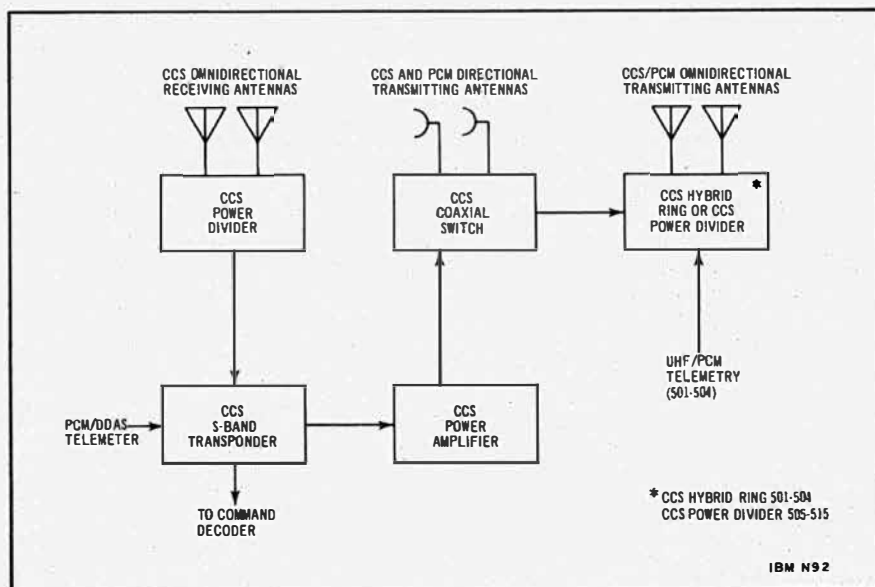

Saturn V Instrument Unit Command and Communications System (CCS) Block Diagram

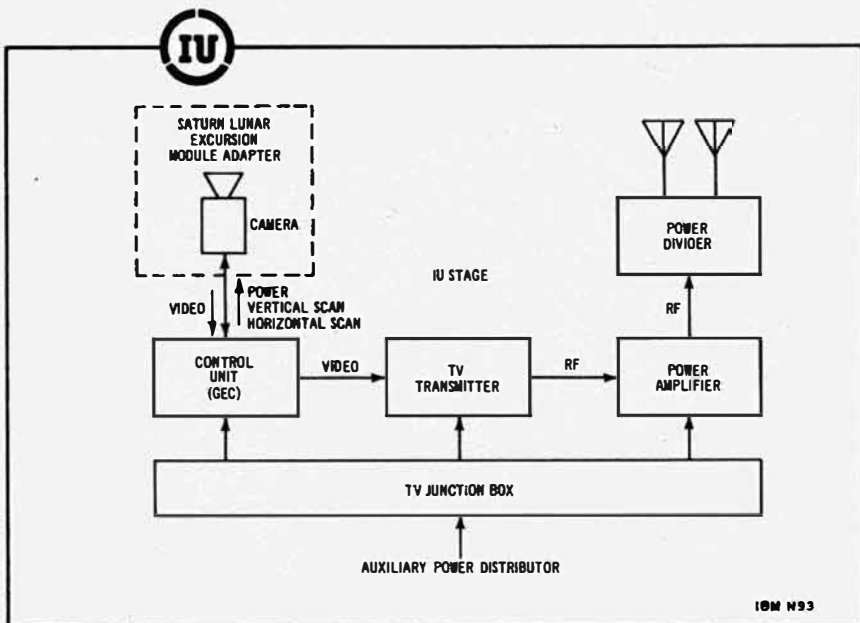

IBM N93

Television System Block Diagram for S-IU-202

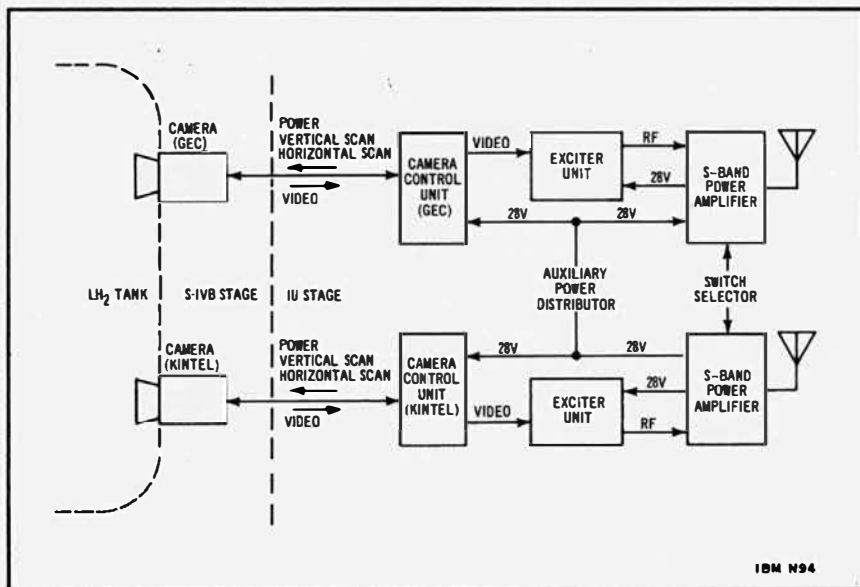

IBM N94

Television System Block Diagram for S-IU-203

# RADIO FREQUENCY SYSTEM

## Azusa RI Filter Assembly

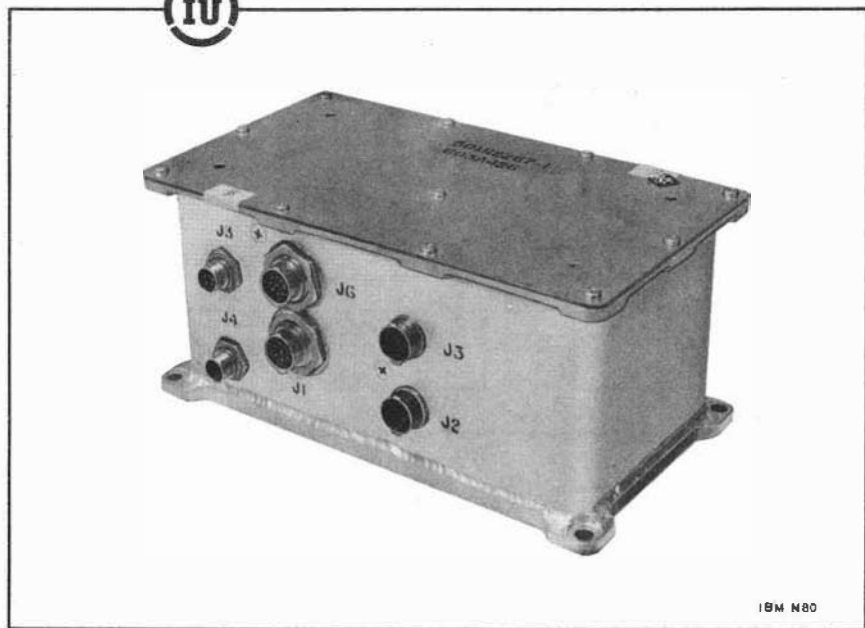

The Azusa RI Filter Assembly performs three functions in the Azusa system:

- Isolates the Azusa Transponder from 28-Vdc power line interference.
- Attenuates conducted interference from the transponder blower motor to the 28 Vdc power source during bench tests.
- Isolates the telemetry network.

**I** Effectivity: 201-204/501-502  
Specification No. Not available  
Figure 1 Location: Panel 23 Callout 109

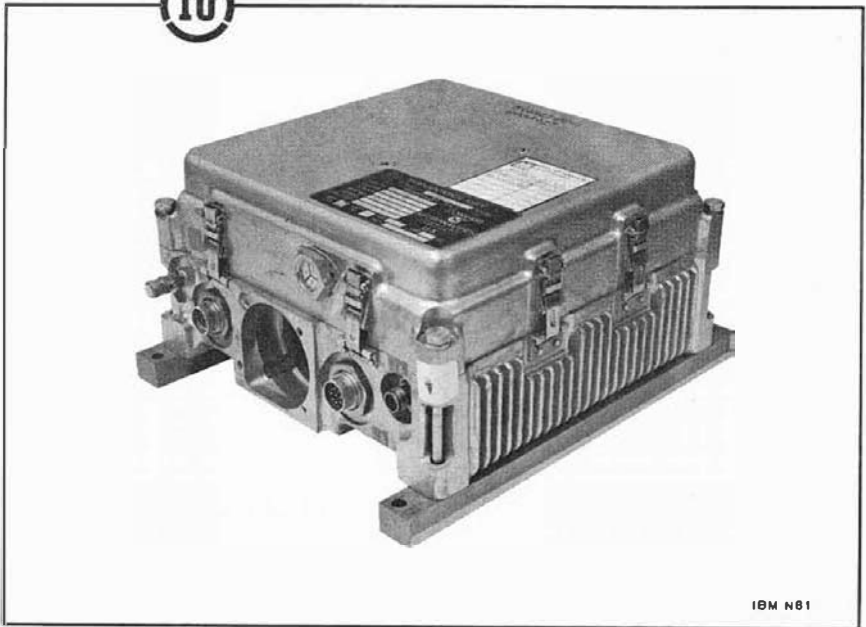

IBM N81

The Azusa Transponder receives a cw C-Band carrier, frequency modulated by range signals, from a ground-based Azusa tracking station. The transponder simultaneously retransmits an offset carrier frequency modulated by the range signals to the ground tracking station. Range measurement is accomplished by measuring the phase delay between the received and transmitted modulation frequencies at the ground station. The remaining measurements, to determine position, are obtained by measuring the phase delay between the received and transmitted carrier frequency.

■ Effectivity: 201-204/501-502  
Specification No. Not available  
Figure 1 Location: Panel 23 Callout 110

# RADIO FREQUENCY SYSTEM

## Camera Control Units

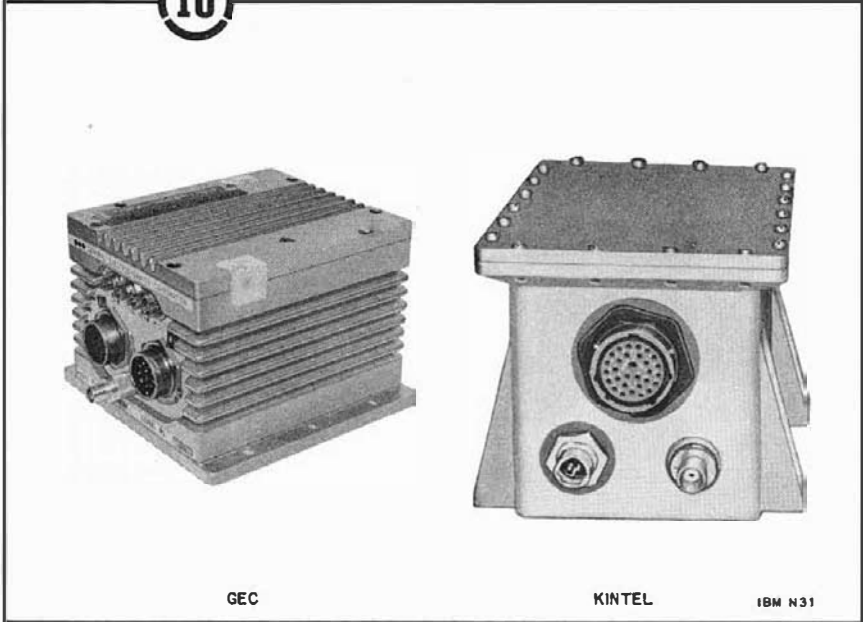

Two types of Camera Control Units are used in the Saturn IB TV system. Both control units are functionally the same but are manufactured by different companies. These control units provide the power, vertical and horizontal scan frequencies, and all the electronics required to operate the TV cameras, with the exception of the vidicon tubes and yoke assemblies and a preamplifier that are contained in the cameras. Each control unit is connected to its associated camera by a cable over which the operating voltages are transferred from the control unit to the camera, and also over which the video signal is transferred from the camera to the control unit. The video signal output of the control unit is applied to the input of its associated transmitter or exciter for subsequent modulation of an FM carrier.

Effectivity:	202-203
Specification No.	Not available
Figure 1 Location:	GEC, Panel 24 Callouts 10 and 19 Kintel, Panel 24 Callout 20

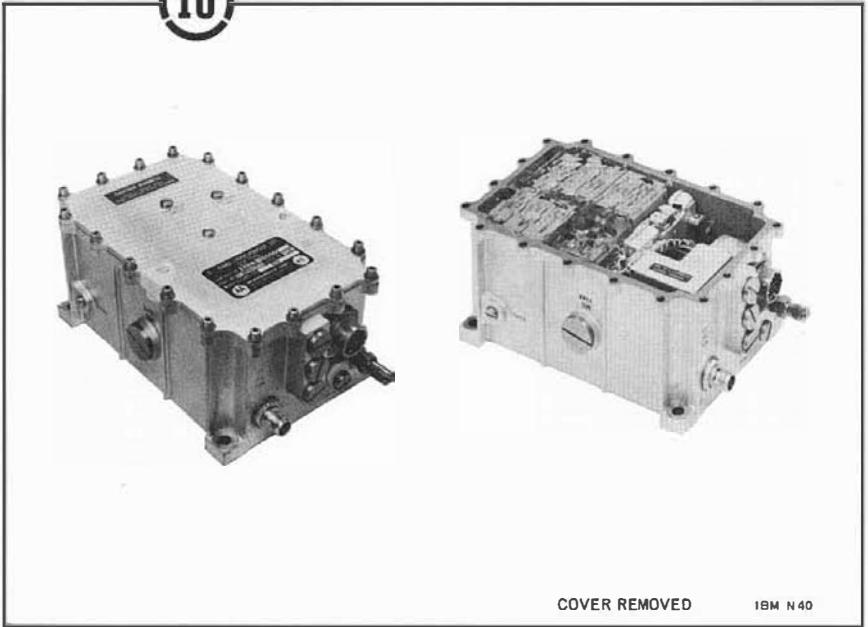

The C-Band Transponder(s) Model SST-135C extends the tracking range of the ground tracking instrumentation radar. The transponder(s) responds to a coded or uncoded pulse from a ground station by transmitting a single-pulse reply in the same frequency band. The ground station determines the position of the vehicle transponder(s) by measuring range, azimuth angle, and elevation angle.

IU 201 through IU 203 contain one C-Band Transponder and one antenna. Two transponders are onboard IU 204 and both respond to an interrogation signal and transmit simultaneously through separate antennas located 180 degrees apart. IU 205 and subsequent also contained two transponders with each transponder connected to a separate antenna. The outputs of the later transponders differ in that their outputs may be selected or inhibited. This output selection is accomplished by using a navigation method of selection; i.e., the LVDC selects one transponder and inhibits the other dependent on vehicle attitude.

Effectivity:	All (Refer to note in Introduction)	
Specification No.	201-202	50M60174
	203	6009038A
	204-205/501	6009132
	206-212/502-515	7907534

Figure 1 Location: Panels 12 and 23 Callouts 71 and 108

# RADIO FREQUENCY SYSTEM

## CCS Coaxial Switch



The CCS Coaxial Switch routes the output of the CCS Power Amplifier to either the CCS Hybrid Ring or the CCS Directional Transmitting Antenna. When in the normally closed position, the coaxial switch routes the signal to the hybrid ring which in turn applies the signal to the CCS/PCM omnidirectional transmitting antennas. The coaxial switch has two other positions; both positions route the signal to the CCS directional antenna. One of the positions applies the signal to a high-gain input, while the other applies the signal to a low-gain input of the CCS directional antenna. Inflight switching of the coaxial switch is controlled by the Switch Selector.

Effectivity:	501-515
Specification No.	Not available
Figure 1 Location:	Panel 24 Callout 25



IBM N83

The CCS Hybrid Ring couples two output signals to the omnidirectional transmitting antennas; the two signals are the outputs of the CCS Coaxial Switch and the UHF PCM coaxial switch. Although the hybrid ring couples both signals to the same antennas, it also isolates the signals from each other. The hybrid ring also provides impedance matching.

Effectivity: 501-504  
Specification No. Not available  
Figure 1 Location: Panel 17 Callout 93



RADIO FREQUENCY SYSTEM  
CCS Power Amplifier

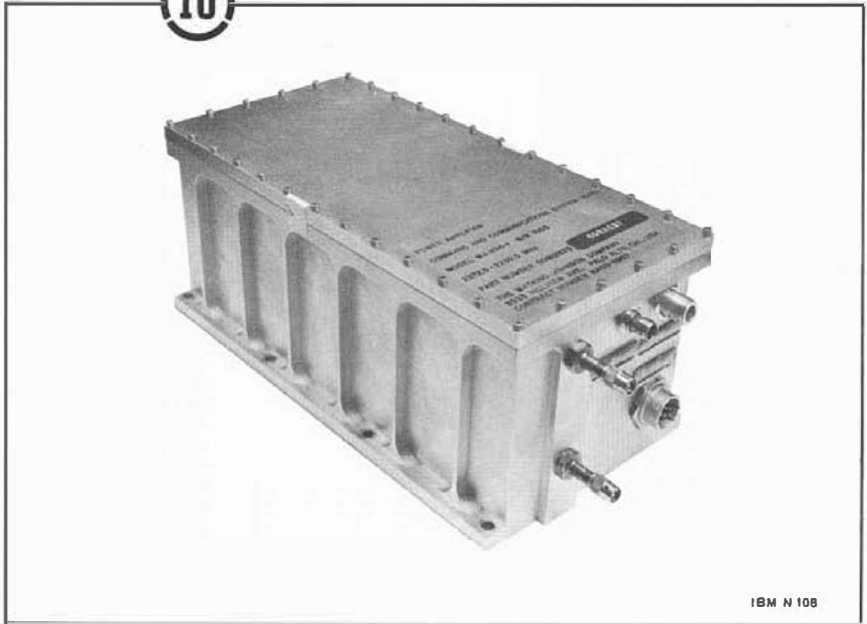

IBM N 108

The CCS Power Amplifier accepts an approximate 500-milliwatt output from the CCS Transponder and amplifies it to approximately a 20 watts output. The power amplifier output is applied to the CCS Coaxial Switch for transmission to the ground by way of one of two antenna arrangements.

Effectivity: 501-515  
Specification No. 501-503 50M60289  
504-515 50Z60289  
Figure 1 Location: Panel 24 Callout 22

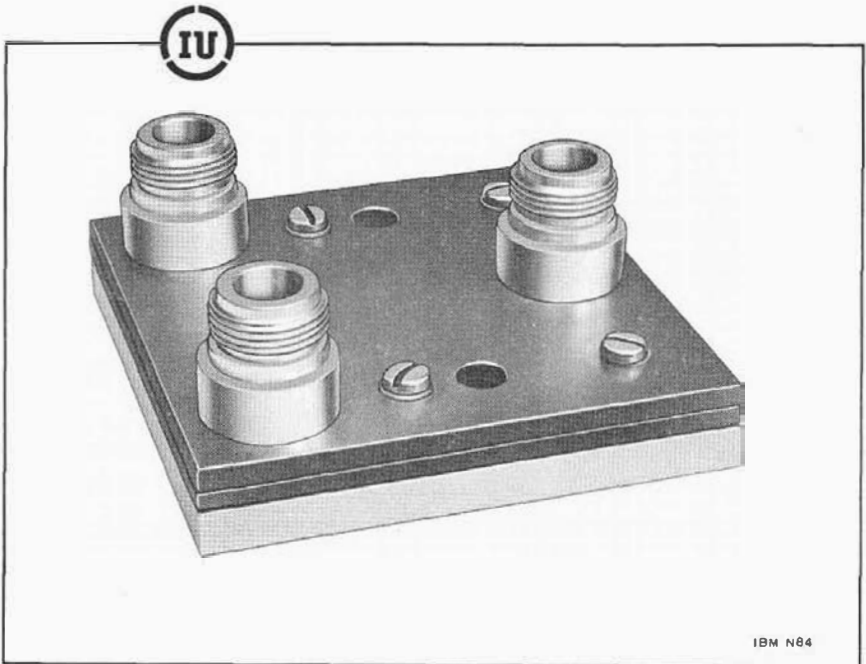

Two CCS Power Dividers are used in the IU. One of the power dividers is used on IU 501 through 515 and accepts inputs from the two CCS Omni-directional Receiving Antennas, couples the input signals, routes them to the CCS Transponder, and provides impedance matching. The second CCS Power Divider is used on IU 505 through 515 to provide impedance matching and couple the output signal from the CCS Coaxial Switch to the CCS Omni-directional Transmitting Antennas.

Effectivity:	501-515
	505-515
Specification No.	501-503 50M60289
	504-515 50Z60289
Figure 1 Location:	Panel 17 Callouts 90E and 94

RADIO FREQUENCY SYSTEM  
CCS Transponder

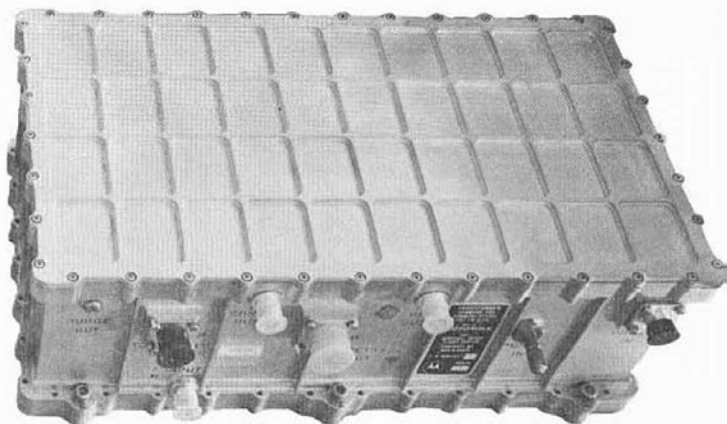

IBM N 109

The CCS Transponder receives a phase modulated carrier input from the CCS Power Divider. This input carrier is modulated by a Pseudo Random Noise (PRN) ranging code for use in tracking, and by a command subcarrier which is frequency modulated with up-link command data. The transponder consists of a double conversion, phase-coherent receiver, and a continuous wave (cw) transmitter that are integrally related in both frequency and phase. Demodulation of the input carrier produces two outputs; one output containing up-link data is applied to the Command Decoder, while the other output containing the PRN ranging code is connected to an amplifier for subsequent modulation of a down-link carrier.

Effectivity:	501-515
Specification No.	501-503 50M60227
	504-515 50Z60227
Figure 1 Location:	Panel 24 Callout 21

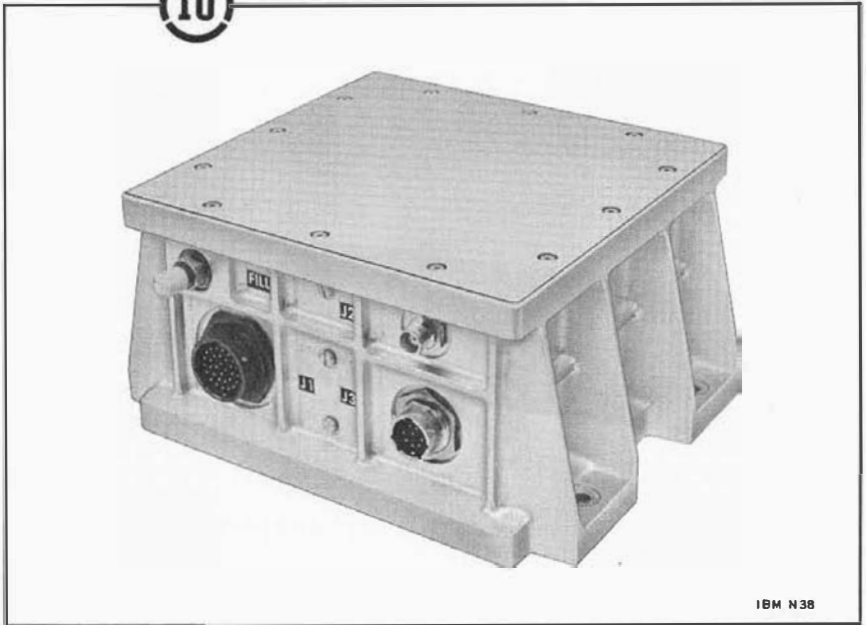

IBM N38

The Command Decoder is the interface unit between the Saturn IB Command Receiver or Saturn V CCS Transponder and the LVDA. Data transmission is made through a 35-bit word, each word bit being composed of 5 sub-bits, on which the Command Decoder performs error checking, decoding, and address verification. Also, the decoder routes two outputs to the PCM telemetry system indicating that the word has been accepted and verified by the LVDC.

Effectivity: 203-212/501-515  
Specification No. 203-205/501, 50M60151  
206-212/502-515, 50Z60151  
Figure 1 Location: Panel 18 Callouts 105 and 107

RADIO FREQUENCY SYSTEM  
Command Directional Coupler

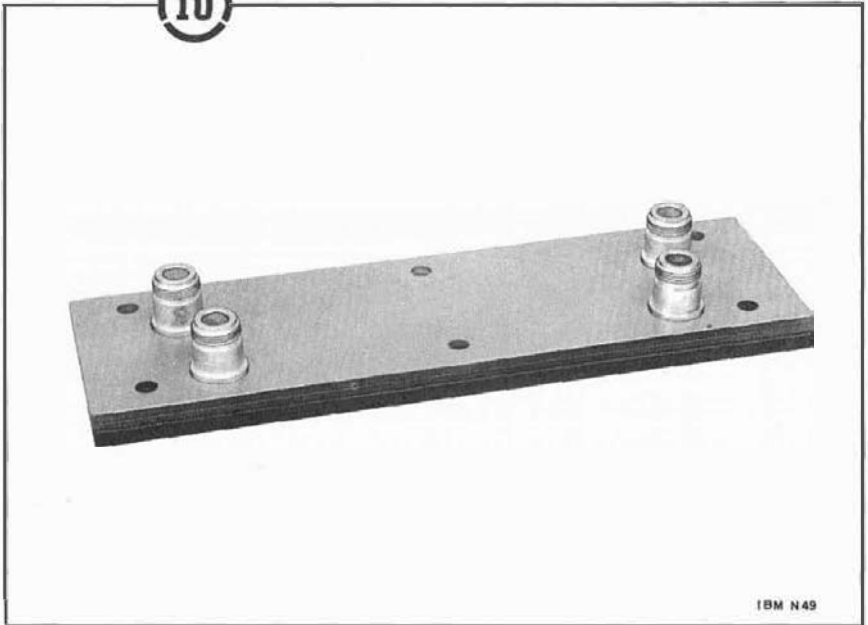

The Command Directional Coupler isolates antenna inputs to the Command Receiver from prelaunch ground equipment test inputs through the umbilical.

Effectivity: 201 & 203-212  
Specification No. 50M60282  
Figure 1 Location: Panel 17 Callout 89

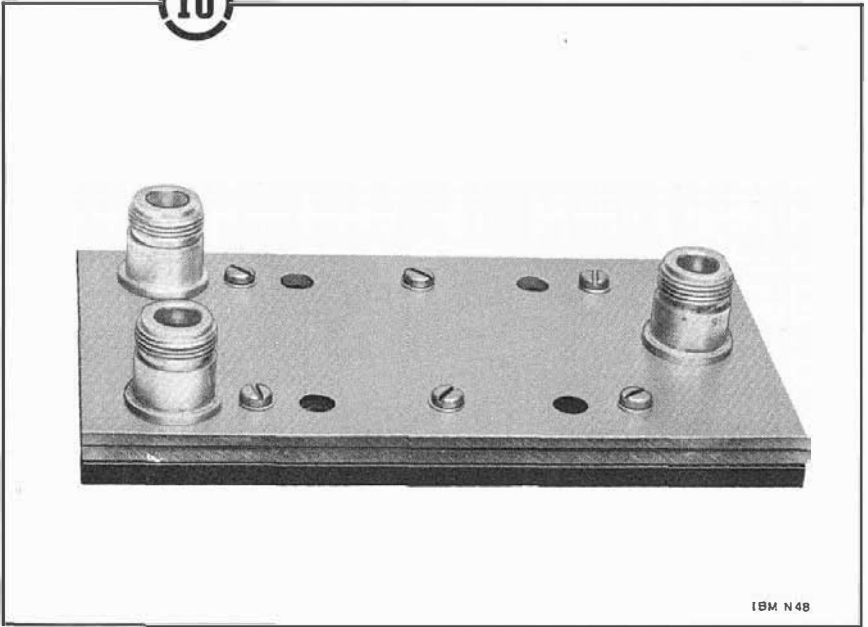

IBM N4B

The Command Power Divider isolates the two omnidirectional receiving antennas from one another and transfers the signal power to the Command Receiver through the directional coupler.

Effectivity: 201 & 203-212  
Specification No. Mod 310 50M60260, Mod 312 50M60285  
Figure 1 Location: Panel 17 Callout 90

# RADIO FREQUENCY SYSTEM

## Command Receiver

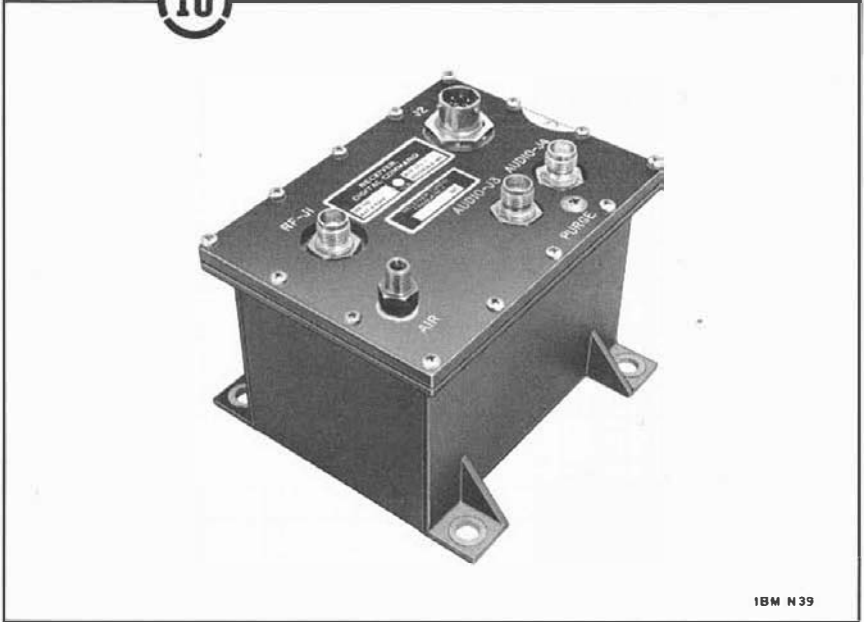

The Command Receiver receives Phase Shift Keyed Frequency Modulated (PSK/FM) signals transmitted from a digital command system ground station. The receiver demodulates the PSK/FM signals and supplies two audio outputs. One audio output is fed to the Command Decoder; the remaining audio output is a spare. The receiver also supplies engineering measurements to the telemetry system for transmission to the ground.

Effectivity: 201 & 203-212  
Specification No. 50M60165  
Figure 1 Location: Panel 18 Callout 98

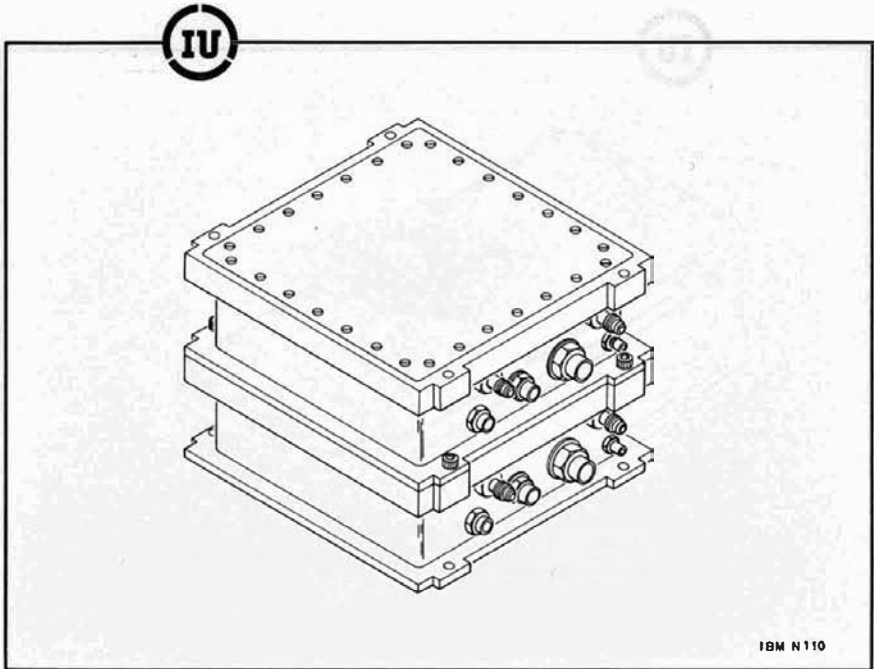

Both Exciter Units receive a video signal from their associated Camera Control Units for subsequent modulation of a carrier frequency developed by crystal-controlled oscillators in the exciters. A 20-milliwatt, frequency modulated output signal from each exciter is applied to individual power amplifiers for filtering and final amplification. Exciter operating power, 28 volts, is received from the power amplifiers. The Exciter Units are stacked as shown above when mounted in the IU.

Effectivity:	203
Specification No.	Not available
Figure 1 Location:	Panel 24 Callout 17



## RADIO FREQUENCY SYSTEM

### S-Band Power Amplifiers

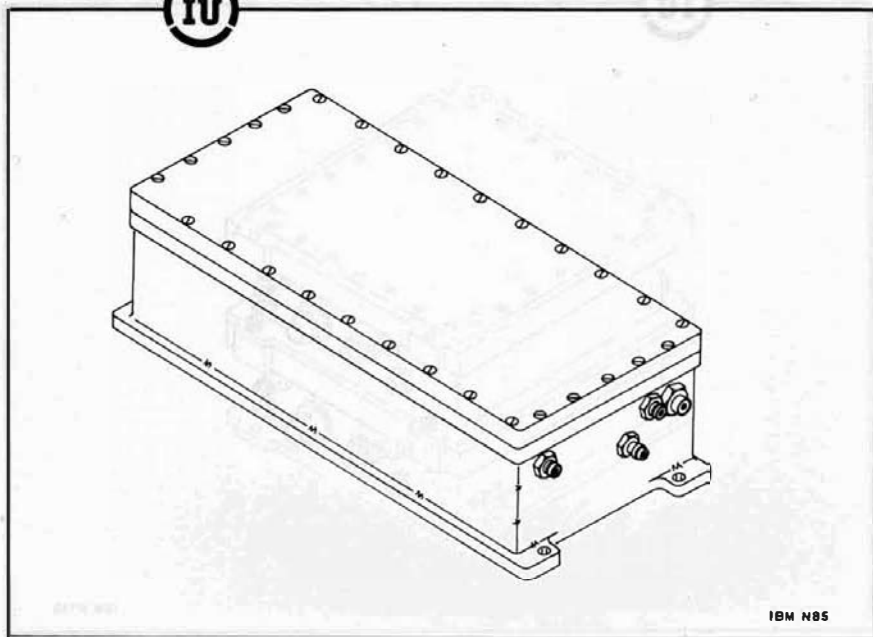

The two S-Band Power Amplifiers accept a 20-milliwatt RF output, frequency modulated with the video signal, from their associated Exciter Units. This composite RF signal is first applied to a bandpass filter within each amplifier and then amplified to attain 20 watts of output power. The output of each power amplifier is connected to a separate antenna. Both of the power amplifier outputs will not be radiated simultaneously; the Switch Selector will select one of the two outputs on command from the ground through the Command System. The resulting frames received at the ground station will be at the standard commercial vertical and horizontal scan rates.

Effectivity:	203
Specification No.	Not available
Figure 1 Location:	Panel 24 Callouts 16 and 18

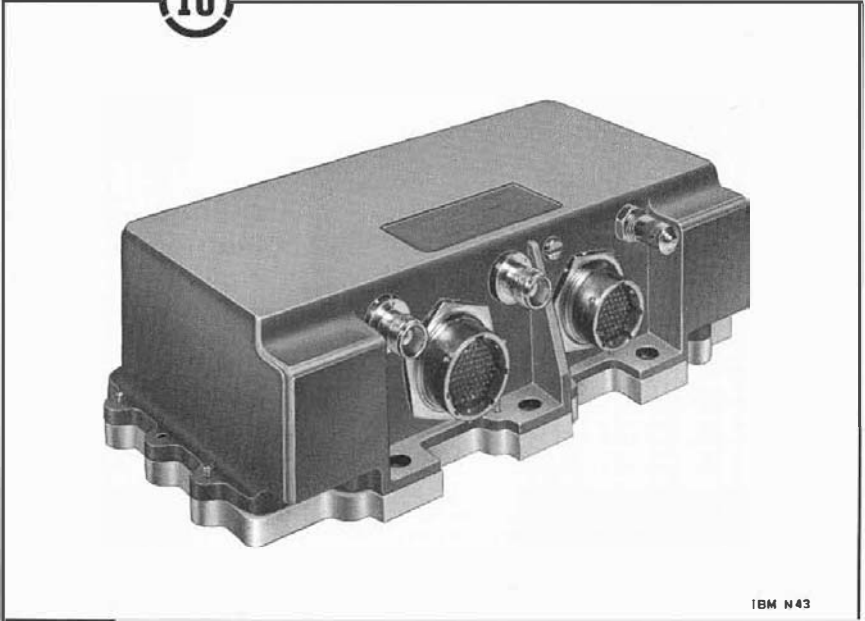

IBM N43

The Secure Range Safety Decoder and associated ground equipment provide a high degree of protection against intentional interrogation by unfriendly intruders and against unintentional interrogation (false alarms) by noise. To command destruction of the vehicle or switch OFF the Range Safety Command System, the decoder must receive the proper audio-frequency tones as well as contain a code plug identical to that which is contained in the associated ground equipment.

Effectivity:	201
Specification No.	Not available
Figure 1 Location:	Panel 18 Callout 99

# RADIO FREQUENCY SYSTEM

## TV Cameras

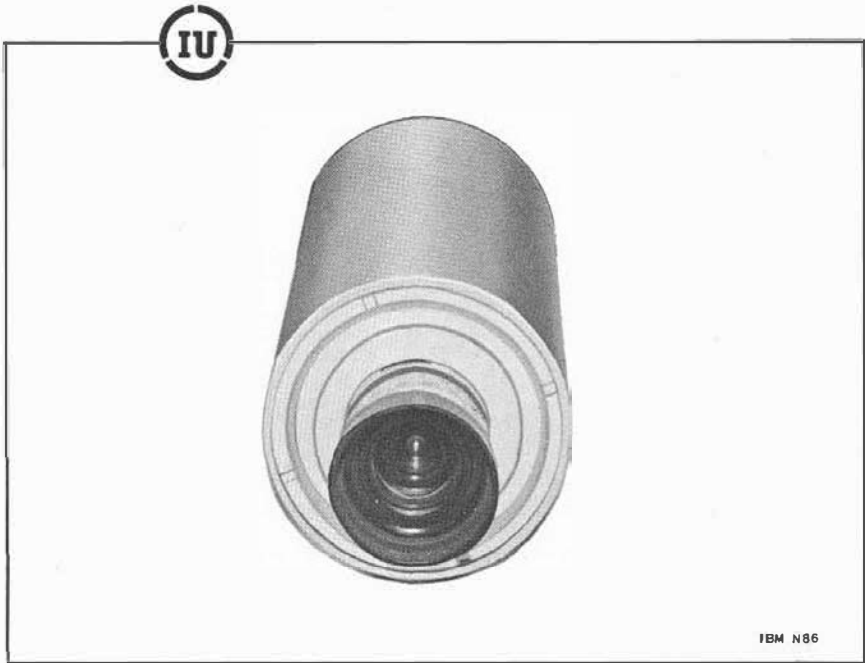

Two types of TV Camera are used to monitor events onboard the Saturn IB vehicle. Both cameras are functionally the same but are manufactured by different companies. The camera utilized onboard vehicle 202 views the Saturn Lunar Excursion Module Adapter so that the IU/Lunar Excursion Module separation can be monitored. Onboard vehicle 203 this camera and the remaining type of camera are used to monitor the status of the fuel in the S-IVB stage LH<sub>2</sub> tank. The cameras and lights, used to illuminate the inside of the tank, are mounted in viewing ports at the top of the tank. The camera units consist of their vidicon tubes, yoke assemblies, preamplifiers and heaters that operate at 40°F and below. All the remaining electronics required to operate the cameras are contained in the Camera Control Unit(s) located in the IU.

Effectivity:	202-203
Specification No.	Not available
Figure 1 Location:	Refer to above description.

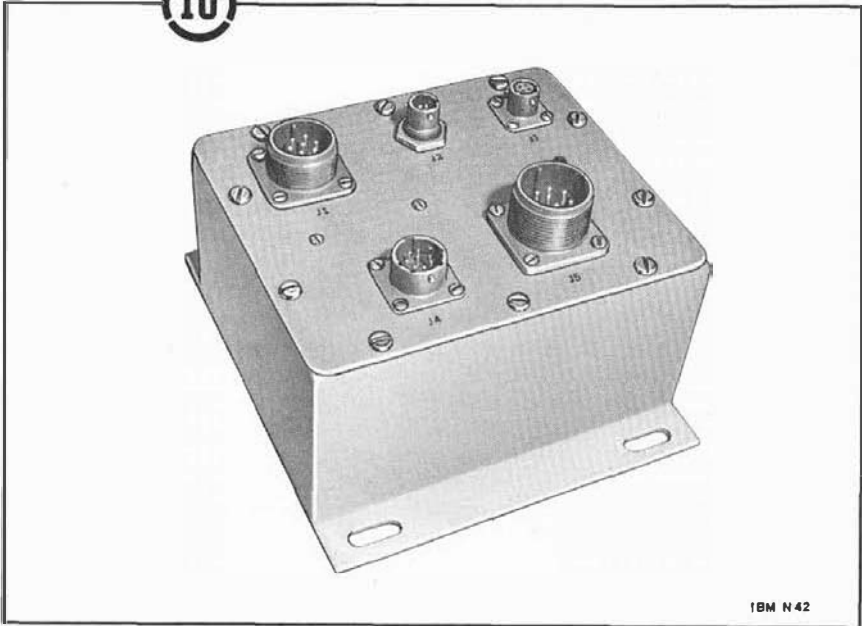

The TV Junction Box serves as a distribution box for all 28-volt power required by the Camera Control Unit, TV Transmitter, and TV Power Amplifier. The input power to the junction box is received from and controlled by normally open magnetic latching relay contacts in an Auxiliary Power Distributor. Power to the junction box, and therefore the TV components, may be applied or removed as desired by energizing or de-energizing the Auxiliary Power Distributor relay through the umbilical during prelaunch operations. Prior to umbilical separation the relay is energized and remains closed for the entire flight.

Effectivity: 202  
Specification No. Not available  
Figure 1 Location: Panel 24 Callout 6

## RADIO FREQUENCY SYSTEM

### TV Power Amplifier

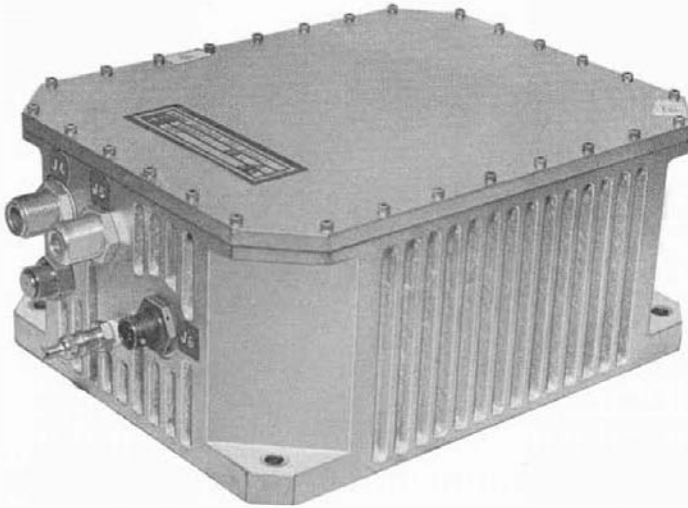

IBM N32

The TV Power Amplifier accepts an approximate 4-watt, frequency modulated RF signal from the TV Transmitter and amplifies it to approximately 20 watts. The output of the power amplifier is applied to the TV Power Divider.

Effectivity:	202
Specification No.	Not available
Figure 1 Location:	Panel 24 Callout 8

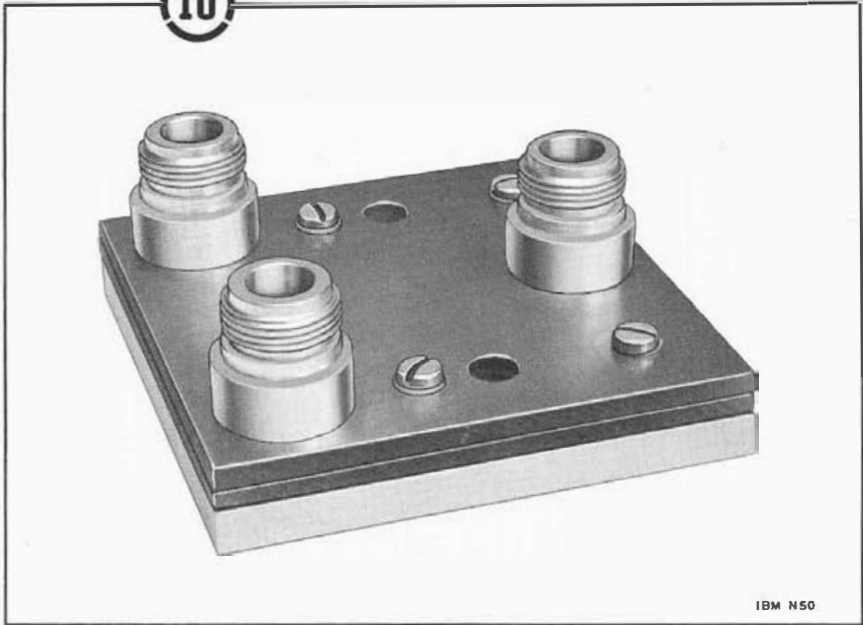

The TV Power Divider routes and equally divides the frequency modulated RF signal from the TV Power Amplifier to the two TV antennas. The power divider also provides impedance matching.

Effectivity: 202  
Specification No. Not available  
Figure 1 Location: Panel 24 Callout 7

# RADIO FREQUENCY SYSTEM

## TV Transmitter

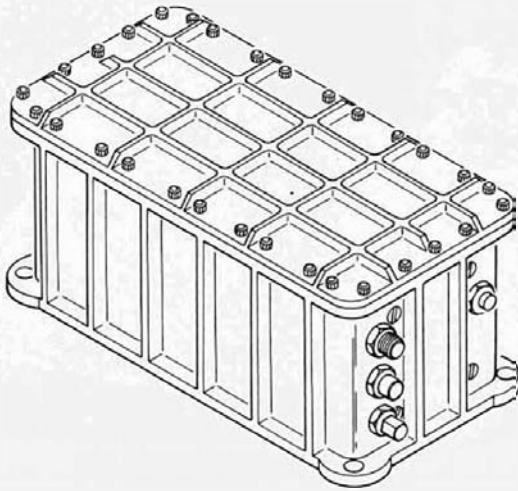

IBM N113

The TV Transmitter accepts a video signal from the Camera Control Unit for subsequent frequency modulation of a carrier developed by a crystal controlled oscillator in the transmitter. The frequency modulated RF output of the transmitter, consisting of the video signal at the standard commercial vertical and horizontal scan rates at approximately 4 watts of power, is applied to the TV Power Amplifier.

Effectivity: 202  
Specification No. Not available  
Figure 1 Location: Panel 24 Callout 9

PANELS 1 THRU 5  
REPLACEMENT DATA



## COMPONENT REMOVAL AND REPLACEMENT DATA

The following pages furnish pertinent information regarding removal and replacement of electronic components mounted on the mounting and thermal conditioning panels of the Instrument Unit. This information is not intended to be used as a procedure, but as a reference to find such things as mounting hardware, tools, Component Handling Equipment (CHE), etc, necessary to remove or replace a component. Also, only those common tools peculiar to the removal or replacement of a specific component are included. For example, it is assumed that a ratchet will also be required when a 7/16-inch socket is specified as tools required.

Description and procedures for use of the CHE can be found in the Component Handling Equipment Descriptions and Procedures manual (IBM 66-966-0005). Illustrations of the various pieces of CHE appear on the following pages.

Component weights are procurement specification maximum weights or, approximate weights and therefore should be used for information only. If the weights included affect your decisions, please check their validity. Mounting hardware listed for components may not be valid in all cases. To obtain up-to-date mounting hardware part numbers, refer to the applicable engineering documentation.

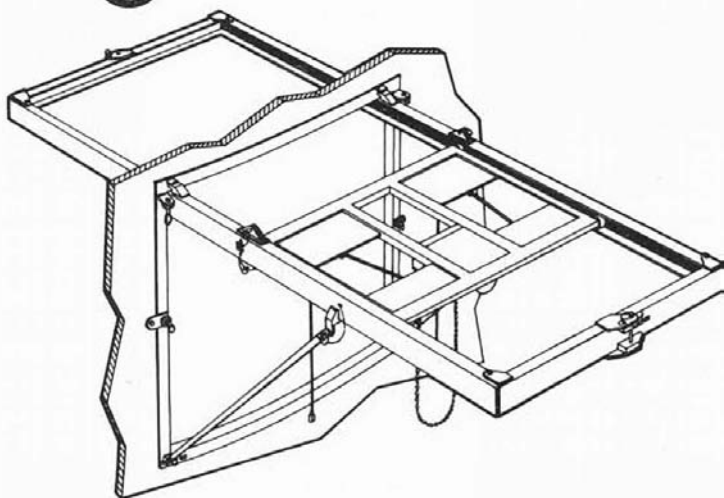

HOIST AND TRACK ASSEMBLY



TRANSPORTER AND ADAPTER ASSEMBLY

IBM N 124-1

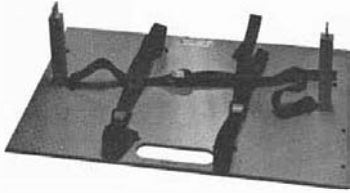

LEM BATTERY FIXTURE ASSEMBLY

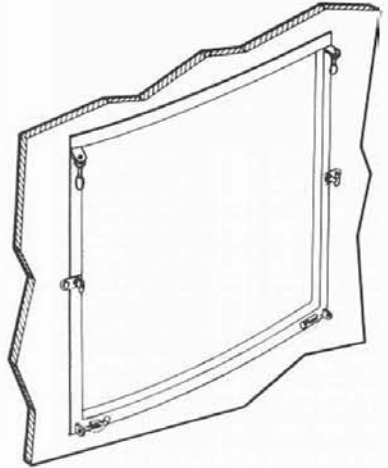

DOOR FRAME ASSEMBLY

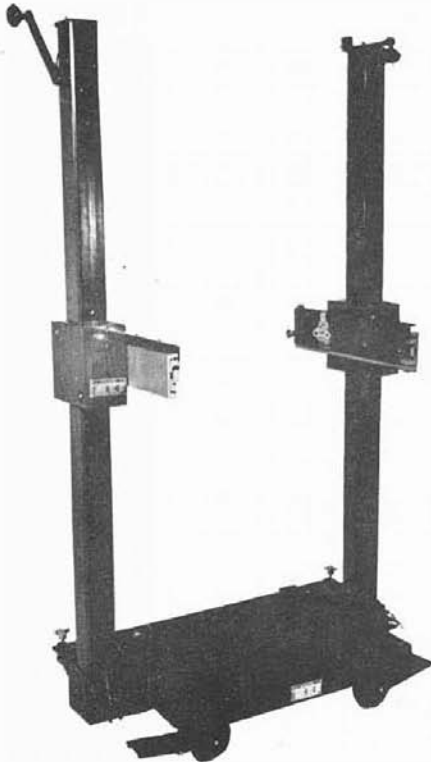

CART ASSEMBLY

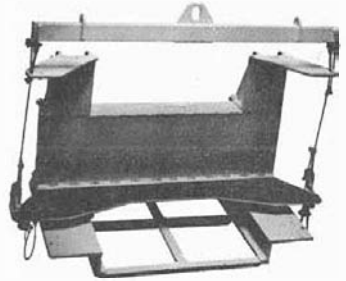

LVDC FIXTURE ASSEMBLY



ST-124M-3 PLATFORM ELECTRONIC  
FIXTURE ASSEMBLY

IBM N124-2

Component Handling Equipment (Sheet 2)



IU BATTERY FIXTURE ASSEMBLY



S-IVB BATTERY FIXTURE ASSEMBLY

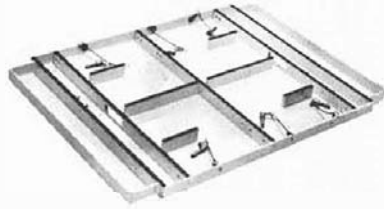

BATTERY TRANSPORTATION BED



FLIGHT CONTROL COMPUTER  
FIXTURE ASSEMBLY

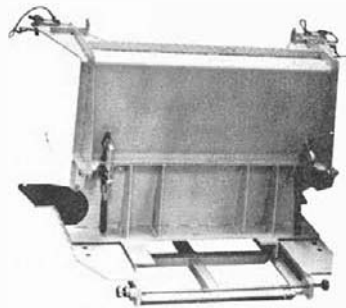

LVDA FIXTURE ASSEMBLY

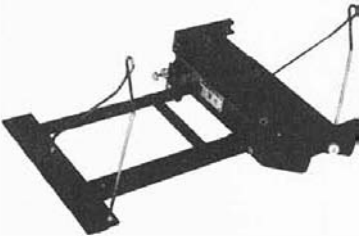

POWER DISTRIBUTOR  
FIXTURE ASSEMBLY



ST-124M-3 INERTIAL PLATFORM  
FIXTURE ASSEMBLY

IBM N124-3

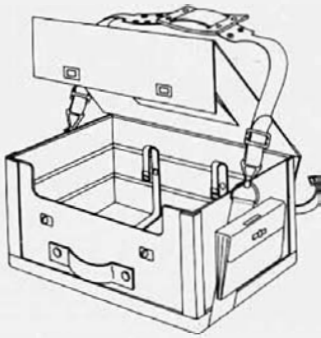

TRANSPORTER BAG

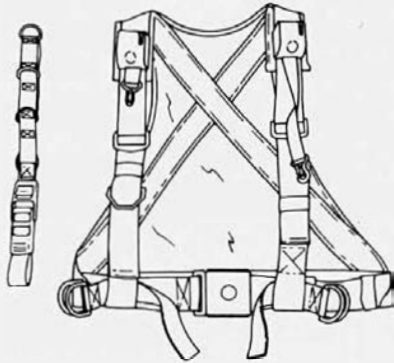

RESTRAINT HARNESS AND  
BELT ASSEMBLY

IBM N124-4

Component Handling Equipment (Sheet 4)

## AUXILIARY POWER DISTRIBUTOR

Figure 1 Location: Panel 1 Callout 4

Manpower: 2 Technicians

Mounting Hardware: Four 1/4-28 by 5-5/16 Screws, AN4-56A  
4 Washers, AN960-416L

Tools Required: 7/16-inch socket  
Guide pins

Torque value for mounting hardware: 85-90 inch pounds

Weight of component: (approximate) 12.5 pounds  
Weight of mounting hardware: 0.1268 pounds

CHE Required: Restraint Harness, P/N 7904049  
Belt Assembly, P/N 7904070-3

Pressurization Required: (Not applicable)

---

## MEASURING RACK A402

Figure 1 Location: Panel 1 Callout 5

Manpower: 2 Technicians

Mounting Hardware: Four 1/4-28 by 1-1/2 Screws, MS16998-47  
4 Washers, NAS620-416

Tools Required: 3/16-inch Allen wrench  
Guide pins

Torque value for mounting hardware: 85-90 inch pounds

Weight of component: (approximate) 21 pounds, with all module slots filled  
Weight of mounting hardware: 0.1128 pounds

CHE Required: Restraint Harness, P/N 7904049  
Belt Assembly, P/N 7904070-3

Pressurization Required: (Not applicable)

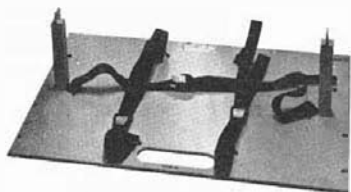

LEM BATTERY FIXTURE ASSEMBLY

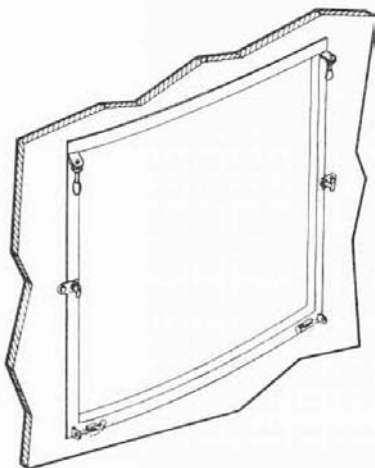

DOOR FRAME ASSEMBLY

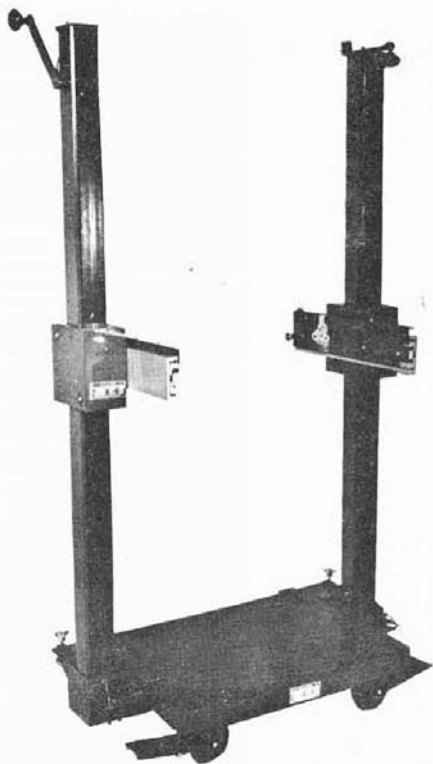

CART ASSEMBLY

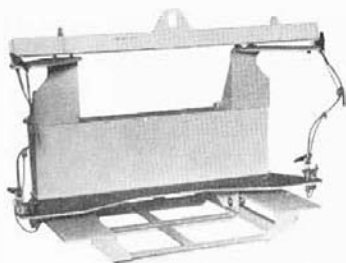

LVDC FIXTURE ASSEMBLY



ST-124M-3 PLATFORM ELECTRONIC  
FIXTURE ASSEMBLY

IBM N124-2



IU BATTERY FIXTURE ASSEMBLY



S-IVB BATTERY FIXTURE ASSEMBLY

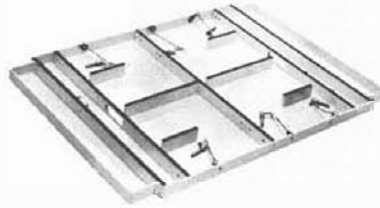

BATTERY TRANSPORTATION BED

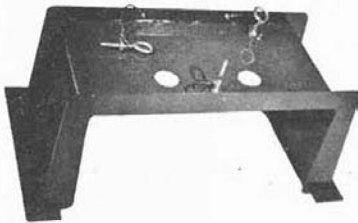

FLIGHT CONTROL COMPUTER  
FIXTURE ASSEMBLY

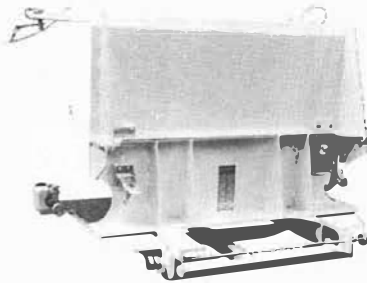

LVDA FIXTURE ASSEMBLY

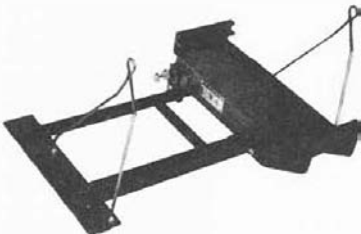

POWER DISTRIBUTOR  
FIXTURE ASSEMBLY



ST-124M-3 INERTIAL PLATFORM  
FIXTURE ASSEMBLY

IBM N 124-3



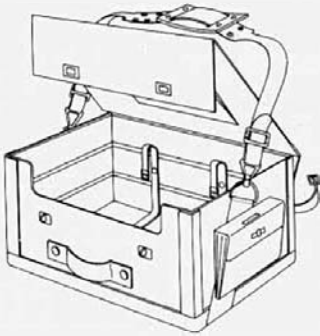

TRANSPORTER BAG

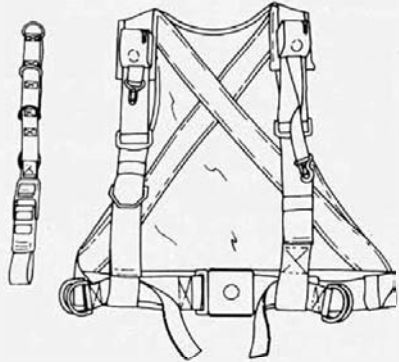

RESTRAINT HARNESS AND  
BELT ASSEMBLY

IBM N 124-4

Component Handling Equipment (Sheet 4)

## AUXILIARY POWER DISTRIBUTOR

Figure 1 Location: Panel 1 Callout 4

Manpower: 2 Technicians

Mounting Hardware: Four 1/4-28 by 5-5/16 Screws, AN4-56A  
4 Washers, AN960-416L

Tools Required: 7/16-inch socket  
Guide pins

Torque value for mounting hardware: 85-90 inch pounds

Weight of component: (approximate) 13.5 pounds  
Weight of mounting hardware: 0.1268 pounds

CHE Required: Restraint Harness, P/N 7904049-1  
Belt Assembly, P/N 7904070-3  
Transporter Bag, P/N 7904090-1

Pressurization Required: (Not applicable)

---

## MEASURING RACK A402

Figure 1 Location: Panel 1 Callout 5

Manpower: 2 Technicians

Mounting Hardware: Four 1/4-28 by 1-1/2 Screws, MS16998-47  
4 Washers, NAS620-416

Tools Required: 3/16-inch Allen wrench  
Guide pins

Torque value for mounting hardware: 85-90 inch pounds

Weight of component: (approximate) 21 pounds, with all module slots filled  
Weight of mounting hardware: 0.1128 pounds

CHE Required: Restraint Harness, P/N 7904049-1  
Belt Assembly, P/N 7904070-3  
Transporter Bag, P/N 7904090-1

Pressurization Required: (Not applicable)

## 56 VOLT POWER SUPPLY

Figure 1 Location: Panel 1 Callout 11

Manpower: 2 Technicians

Mounting Hardware: Four 1/4-28 by 1-1/2 Screws, MS16998-47  
4 Washers, NAS620-416L

Tools Required: 3/16-inch Allen wrench  
Guide pins

Torque value for mounting hardware: 85-90 inch pounds

Weight of component: (approximate) 11.0 pounds  
Weight of mounting hardware: 0.108 pounds

CHE Required: Restraint Harness, P/N 7904049-1  
Belt Assembly, P/N 7904070-3  
Transporter Bag, P/N 7904090-1

Pressurization Required: (Not applicable)

---

## MEASURING RACK SELECTOR

Figure 1 Location: Panel 1 Callout 12

Manpower: 2 Technicians

Mounting Hardware: Four 1/4-28 by 1-1/2 Screws, MS16998-47  
4 Washers, NAS620-416

Tools Required: 3/16-inch Allen wrench  
Guide pins

Torque value for mounting hardware: 85-90 inch pounds

Weight of component: (maximum) 3.0 pounds  
Weight of mounting hardware: 0.1128 pounds

CHE Required: Restraint Harness, P/N 7904049-1  
Belt Assembly, P/N 7915991-1  
Transporter Bag, P/N 7904090-1

Pressurization Required: (Not applicable)

## SOURCE FOLLOWER

Figure 1 Location: Panel 1 Callout 13

Manpower: 1 Technician

Mounting Hardware: Two 1/4-28 by 1-1/4 Screws, MS16998-46  
2 Washers, NAS620-416L

Tools Required: 3/16-inch Allen wrench  
Guide pins

Torque value for mounting hardware: 85-90 inch pounds

Weight of component: (maximum) 0.2 pounds  
Weight of mounting hardware: 0.0474 pounds

CHE Required: None

Pressurization Required: (Not applicable)

---

## MEASURING RACK A401

Figure 1 Location: Panel 2 Callout 1

Manpower: 2 Technicians

Mounting Hardware: Four 1/4-28 by 1-1/2 Screws, MS16998-47  
4 Washers, NAS620-416

Tools Required: 3/16-inch Allen wrench  
Guide pins

Torque value for mounting hardware: 85-90 inch pounds

Weight of component: (approximate) 21 pounds, with all module slots filled  
Weight of mounting hardware: 0.1128 pounds

CHE Required: Restraint Harness, P/N 7904049-1  
Belt Assembly, P/N 7904070-3  
Transporter Bag, P/N 7904090-1

Pressurization Required: (Not applicable)

## POWER DISTRIBUTOR

Figure 1 Location: Panel 2 Callout 2

Manpower: 4 Technicians

Mounting Hardware: Six 1/4-28 by 1-3/4 Screws, MS16998-48  
6 Washers, NAS620-416

Tools Required: 3/16-inch Allen wrench  
Guide pins

Torque value for mounting hardware: 85-90 inch pounds

Weight of component: (approximate) 41 pounds

Weight of mounting hardware: 0.1260 pounds

CHE Required: Door Frame Assembly, P/N 7902257  
Top Channel Assembly, P/N 7902255  
Cart Assembly, P/N 7902170  
Hoist and Track Assembly, P/N 7902259  
2 Tube Assemblies, P/N 7902256  
Transporter and Adapter Assembly, P/N 7904080  
Power Distributor Fixture Assembly, P/N 7904066

Pressurization Required: (Not applicable)

---

## ELECTRONIC CONTROLLER ASSEMBLY

Figure 1 Location: Panel 2 Callout 14

Manpower: 1 Technician

Mounting Hardware: Four 1/4-28 by 1-1/2 Screws, MS16998-47  
4 Washers, NAS620-416

Tools Required: 3/16-inch Allen wrench  
Guide pins

Torque value for mounting hardware: 85-90 inch pounds

Weight of component: (maximum) 2.0 pounds

Weight of mounting hardware: 0.1128 pounds

CHE Required: None

Pressurization Required: (Not applicable)

## CONTROL ACCELEROMETER (PITCH)

Figure 1 Location: Panel 2 Callout 15

Manpower: 1 Technician

Mounting Hardware: Four # 8-32 by 3/4 Screws, MS16997-34  
4 Washers, NAS620-8

Tools Required: 9/64-inch Allen wrench  
Guide pins

Torque value for mounting hardware: 85-90 inch pounds

Weight of component: (maximum) 5.0 pounds  
Weight of mounting hardware: (Not available)

CHE Required: Restraint Harness, P/N 7904049-1  
Belt Assembly, P/N 7915991-1  
Transporter Bag, P/N 7904090-1

Pressurization Required: (Not applicable)

---

## BATTERIES D30 AND D40

Figure 1 Location: Panel 4 Callouts 27 and 28

Manpower: 4 Technicians

Mounting Hardware: Two 1/4-28 by 5/8 Screw, MS16998-42  
Eight 1/4-28 by 1-3/4 Screw, MS16998-48  
Three 1/4-28 by 3/4 Screws, MS16998-43  
13 Washers, NAS620-416

Tools Required: 3/16-inch Allen wrench  
Guide pins

Torque value for mounting hardware: 85-90 inch pounds

Weight of component: (approximate) 170 pounds  
Weight of mounting hardware: 0.1031 pounds

CHE Required: Door Frame Assembly, P/N 7902257  
Top Channel Assembly, P/N 7902255  
Cart Assembly, P/N 7902170  
Hoist and Track Assembly, P/N 7902259  
2 Tube Assemblies, P/N 7902256  
Transporter and Adapter Assembly, P/N 7904080  
Battery Fixture, P/N 7904000

Pressurization Required: (Not applicable)

## TELEMETRY POWER DIVIDER

Figure 1 Location: Panel 4 Callout 29

Manpower: 1 Technician

Mounting Hardware: Six 1/4-28 by 1 Screws, MS16998-45  
6 Washers, NAS620-416  
12 Washers, NAS549F416

Tools Required: 3/16-inch Allen wrench  
Guide pins

Torque value for mounting hardware: 40-45 inch pounds

Weight of component: (maximum) 1.0 pounds  
Weight of mounting hardware: (Not available)

CHE Required: None

Pressurization Required: (Not applicable)

---

## COAXIAL TERMINATION

Figure 1 Location: Panel 4 Callout 30

Manpower: 1 Technician

Mounting Hardware: Four 1/4-28 by 1-1/2 Screws, MS16998-47  
4 Washers, NAS620-416

Tools Required: 3/16-inch Allen wrench  
Guide pins

Torque value for mounting hardware: 85-90 inch pounds

Weight of component: (maximum) 4.75 pounds  
Weight of mounting hardware: 0.1128 pounds

CHE Required: Restraint Harness, P/N 7904049-1  
Belt Assembly, P/N 7915991-1  
Transporter Bat, P/N 7904090-1

Pressurization Required: (Not applicable)

## COAXIAL SWITCH

Figure 1 Location: Panel 4 Callout 31

Manpower: 1 Technician

Mounting Hardware: Four #10-28 by 2 Screws, MS16998-35  
8 Washers, NAS549F10  
8 Washers, NAS620-10L  
4 Self-Locking Nuts, MS20364-1032

Tools Required: 5/32-inch Allen wrench  
3/8-inch socket

Torque value for mounting hardware: 85-90 inch pounds

Weight of component: (maximum) 1.0 pounds  
Weight of mounting hardware: 0.1912 pounds

CHE Required: None

Pressurization Required: (Not applicable)

---

## BATTERIES D10 AND D20

Figure 1 Location: Panel 5 Callouts 26 and 32

Manpower: 4 Technicians

Mounting Hardware: Two 1/4-28 by 5/8 Screw, MS16998-42  
Eight 1/4-28 by 1-3/4 Screw, MS16998-48  
Three 1/4-28 by 3/4 Screws, MS16998-43  
13 Washers, NAS620-416

Tools Required: 3/16-inch Allen wrench  
Guide pins

Torque value for mounting hardware: 85-90 inch pounds

Weight of component: (maximum) 165 pounds  
Weight of mounting hardware: 0.1031 pounds

CHE Required: Door Frame Assembly, P/N 7902257  
Top Channel Assembly, P/N 7902255  
Cart Assembly, P/N 7902170  
Hoist and Track Assembly, P/N 7902259  
2 Tube Assemblies, P/N 7902256  
Transporter and Adapter Assembly, P/N 7904080  
Battery Fixture, P/N 7904000

Pressurization Required: (Not applicable)



PANELS 9 THRU 13  
REPLACEMENT DATA

## MEASURING RACK A405

Figure 1 Location: Panel 9 Callout 50

Manpower: 2 Technicians

Mounting Hardware: Four 1/4-28 by 1-1/2 Screws, MS16998-47  
4 Washers, NAS620-416

Tools Required: 3/16-inch Allen wrench  
Guide pins

Torque value for mounting hardware: 85-90 inch pounds

Weight of component: (approximate) 21 pounds, with all module slots filled  
Weight of mounting hardware: 0.1128 pounds

CHE Required: Restraint Harness, P/N 7904049-1  
Belt Assembly, P/N 7904070-3  
Transporter Bag, P/N 7904090-1

Pressurization Required: (Not applicable)

---

## AUXILIARY POWER DISTRIBUTOR

Figure 1 Location: Panel 9 Callout 51

Manpower: 2 Technicians

Mounting Hardware: Four 1/4-28 by 5-5/16 Screws, AN4-56A  
4 Washers, AN960-416L

Tools Required: 7/16-inch socket  
Guide pins

Torque value for mounting hardware: 85-90 inch pounds

Weight of component: (approximate) 13.5 pounds  
Weight of mounting hardware: 0.1268 pounds

CHE Required: Restraint Harness, P/N 7904049-1  
Belt Assembly, P/N 7904070-3  
Transporter Bag, P/N 7904090-1

Pressurization Required: (Not applicable)

## CP1 MULTIPLEXER ASSEMBLY

Figure 1 Location: Panel 9 Callout 52

Manpower: 2 Technicians

Mounting Hardware: Four 1/4-28 by 1-3/4 Screws, MS16998-48  
4 Washers, NAS620-416

Tools Required: 3/16-inch Allen wrench  
Guide pins

Torque value for mounting hardware: 85-90 inch pounds

Weight of component: (maximum) 21 pounds  
Weight of mounting hardware: 0.1128 pounds

CHE Required: Restraint Harness, P/N 7904049-1  
Belt Assembly, P/N 7904070-3  
Transporter Bag, P/N 7904090-1

Pressurization Required: (Not applicable)

---

## DP1 MULTIPLEXER ASSEMBLY

Figure 1 Location: Panel 9 Callout 52

Manpower: 2 Technicians

Mounting Hardware: Four 1/4-28 by 1-3/4 Screws, MS16998-48  
4 Washers, NAS620-416

Tools Required: 3/16-inch Allen wrench  
Guide pins

Torque value for mounting hardware: 85-90 inch pounds

Weight of component: (maximum) 21 pounds  
Weight of mounting hardware: 0.1212 pounds

CHE Required: Restraint Harness, P/N 7904049-1  
Belt Assembly, P/N 7904070-3  
Transporter Bag, P/N 7904090-1

Pressurization Required: (Not applicable)

## TELEMETRY RF COUPLER

Figure 1 Location: Panel 9 Callout 53

Manpower: 1 Technician

Mounting Hardware: Four 1/4-28 by 1-1/2 Screw, MS16998-47  
4 Washers, NAS620-416L

Tools Required: 3/16-inch Allen wrench  
Guide pins

Torque value for mounting hardware: 85-90 inch pounds

Weight of component: (maximum) 3 pounds  
Weight of mounting hardware: 0.108 pounds

CHE Required: Restraint Harness, P/N 7904049-1  
Belt Assembly, P/N 7915991-1  
Transporter Bag, P/N 7904090-1

Pressurization Required: (Not applicable)

## F2 RF TRANSMITTER ASSEMBLY

Figure 1 Location: Panel 9 Callout 54

Manpower: 2 Technicians

Mounting Hardware: Four 1/4-28 by 1-3/4 Screws, MS16998-48  
4 Washers, NAS620-416

Tools Required: 3/16-inch Allen wrench  
Guide pins

Torque value for mounting hardware: 85-90 inch pounds

Weight of component: (maximum) 19.5 pounds  
Weight of mounting hardware: 0.1260 pounds

CHE Required: Restraint Harness, P/N 7904049-1  
Belt Assembly, P/N 7904070-3  
Transporter Bag, P/N 7094090-1

Pressurization Required: 5.3 psig

---

## TELEMETRY RF COUPLER

Figure 1 Location: Panel 9 Callout 60

Manpower: 1 Technician

Mounting Hardware: Four 1/4-28 by 1-1/2 Screws, MS16998-48  
4 Washers, NAS620-416

Tools Required: 3/16-inch Allen wrench  
Guide pins

Torque value for mounting hardware: 85-90 inch pounds

Weight of component: (Not available)  
Weight of mounting hardware: 0.1128 pounds

CHE Required: Restraint Harness, P/N 7904049-1  
Belt Assembly, P/N 7915991-1  
Transporter Bag, P/N 7904090-1

Pressurization Required: (Not applicable)

## MEASURING DISTRIBUTOR

Figure 1 Location: Panel 10 Callout 48

Manpower: 2 Technicians

Mounting Hardware: Four 1/4-28 by 3-5/16 Screws, AN4-36A  
4 Washers, AN960-416

Tools Required: 7/16-inch socket  
Guide pins

Torque value for mounting hardware: 85-90 inch pounds

Weight of component: (approximate) 21 pounds  
Weight of mounting hardware: 0.0932 pounds

CHE Required: Restraint Harness, P/N 7904049-1  
Belt Assembly, P/N 7904070-1  
Transporter Bag, P/N 7904090-1

Pressurization Required: (Not applicable)

---

## DP1 MULTIPLEXER ASSEMBLY

Figure 1 Location: Panel 10 Callout 49

Manpower: 2 Technicians

Mounting Hardware: Four 1/4-28 by 1-3/4 Screws, MS16998-48  
4 Washers, NAS620-416

Tools Required: 3/16-inch Allen wrench  
Guide pins

Torque value for mounting hardware: 85-90 inch pounds

Weight of component: (maximum) 21 pounds  
Weight of mounting hardware: 0.1212 pounds

CHE Required: Restraint Harness, P/N 7904049-1  
Belt Assembly, P/N 7904070-3  
Transporter Bag, P/N 7904090-1

Pressurization Required: (Not applicable)

## CP1 MULTIPLEXER ASSEMBLY

Figure 1 Location: Panel 10 Callout 49

Manpower: 2 Technicians

Mounting Hardware: Four 1/4-28 by 1-3/4 Screws, MS16998-48  
4 Washers, NAS620-416

Tools Required: 3/16-inch Allen wrench  
Guide pins

Torque value for mounting hardware: 85-90 inch pounds

Weight of component: (maximum) 21 pounds  
Weight of mounting hardware: 0.1212 pounds

CHE Required: Restraint Harness, P/N 7904049-1  
Belt Assembly, P/N 7904070-3  
Transporter Bag, P/N 7904090-1

Pressurization Required: (Not applicable)

---

## VSWR MEASURING ASSEMBLY

Figure 1 Location: Panel 10 Callout 61

Manpower: 1 Technician

Mounting Hardware: Six 1/4-28 by 1-1/2 Screws, MS16998-47  
6 Washers, NAS620-416L

Tools Required: 3/16-inch Allen wrench  
Guide pins

Torque value for mounting hardware: 40-45 inch pounds

Weight of component: (maximum) 6 pounds  
Weight of mounting hardware: 0.108 pounds

CHE Required: Restraint Harness, P/N 7904049-1  
Belt Assembly, P/N 7915991-1  
Transporter Bag, P/N 7904090-1

Pressurization Required: (Not applicable)

## TELEMETRY DIRECTIONAL COUPLER

Figure 1 Location: Panel 10 Callout 65

Manpower: 1 Technician

Mounting Hardware: Four 1/4-28 by 1-3/4 Screws, MS16998-48  
4 Washers, NAS620-416L

Tools Required: 3/16-inch Allen wrench  
Guide pins

Torque value for mounting hardware: 40-45 inch pounds

Weight of component: (maximum) 1 pound  
Weight of mounting hardware: 0.1764 pounds

CHE Required: None

Pressurization Required: (Not applicable)

---

## F2 TELEMETER ASSEMBLY

Figure 1 Location: Panel 10 Callout 56

Manpower: 2 Technicians

Mounting Hardware: Four 1/4-28 by 1-3/4 Screws, MS16998-48  
4 Washers, NAS620-416

Tools Required: 3/16-inch Allen wrench  
3-inch extension  
Guide pins

Torque value for mounting hardware: 85-90 inch pounds

Weight of component: (maximum) 14 pounds  
Weight of mounting hardware: 0.126 pounds

CHE Required: Restraint Harness, P/N 7904049-1  
Belt Assembly, P/N 7904070-3  
Transporter Bag, P/N 7904090-1

Pressurization Required: 5.3 psig



## SLOW SPEED MULTIPLEXER ASSEMBLY

Figure 1 Location: Panel 11 Callout 45

Manpower: 2 Technicians

Mounting Hardware: Four 1/4-28 by 1-3/4 Screws, MS16998-48  
4 Washers, NAS620-416

Tools Required: 3/16-inch Allen wrench  
Guide pins

Torque value for mounting hardware: 85-90 inch pounds

Weight of component: (maximum) 12.5 pounds  
Weight of mounting hardware: 0.1260 pounds

CHE Required: Restraint Harness, P/N 7904049-1  
Belt Assembly, P/N 7904070-3  
Transporter Bag, P/N 7904090-1

Pressurization Required: (Not applicable)

---

## TAPE RECORDER (AIRBORNE)

Figure 1 Location: Panel 11 Callout 46

Manpower: 2 Technicians

Mounting Hardware: Four 1/4-28 by 1-3/4 Screws, MS16998-48  
4 Washers, NAS602-416L

Tools Required: 3/16-inch Allen wrench  
Guide pins

Torque value for mounting hardware: 85-90 inch pounds

Weight of component: (maximum) 9 pounds  
Weight of mounting hardware: 0.108 pounds

CHE Required: Restraint Harness, P/N 7904049-1  
Belt Assembly, P/N 7904070-5  
Transporter Bag, P/N 7904090-1

Pressurization Required: 5.3 psig

## MEASURING RACK A403

Figure 1 Location: Panel 11 Callout 47

Manpower: 2 Technicians

Mounting Hardware: Four 1/4-28 by 1-1/2 Screws, MS16998-47  
4 Washers, NAS620-416

Tools Required: 3/16-inch Allen wrench  
Guide pins

Torque value for mounting hardware: 85-90 inch pounds

Weight of component: (approximate) 21 pounds, with all module slots filled  
Weight of mounting hardware: 0.1128 pounds

CHE Required: Restraint Harness, P/N 7904049-1  
Belt Assembly, P/N 7904070-3  
Transporter Bag, P/N 7904090-1

Pressurization Required: (Not applicable)

---

## S1 RF TRANSMITTER ASSEMBLY

Figure 1 Location: Panel 11 Callout 57

Manpower: 2 Technicians

Mounting Hardware: Four 1/4-28 by 1-3/4 Screws, MS16998-48  
4 Washers, NAS620-416

Tools Required: 3/16-inch Allen wrench  
Guide pins

Torque value for mounting hardware: 85-90 inch pounds

Weight of component: (maximum) 19.5 pounds  
Weight of mounting hardware: 0.1260 pounds

CHE Required: Restraint Harness, P/N 7904049-1  
Belt Assembly, P/N 7904070-3  
Transporter Bag, P/N 7904090-1

Pressurization Required: 5.3 psig

## S1 TELEMETER ASSEMBLY

Figure 1 Location: Panel 11 Callout 58

Manpower: 2 Technicians

Mounting Hardware: Four 1/4-28 by 1-1/2 Screws, MS16998-47  
4 Washers, NAS620-416L

Tools Required: 3/16-inch Allen wrench  
Guide pins

Torque value for mounting hardware: 85-90 inch pounds

Weight of components: (maximum) 18 pounds  
Weight of mounting hardware: 0.1080 pounds

CHE Required: Restraint Harness, P/N 7904049-1  
Belt Assembly, P/N 7904070-3  
Transporter Bag, P/N 7904090-1

Pressurization Required: (Not applicable)

---

## REMOTE DIGITAL MULTIPLEXER

Figure 1 Location: Panel 11 Callout 59

Manpower: 2 Technicians

Mounting Hardware: Four 1/4-28 by 1-3/4 Screws, MS16998-48  
4 Washers, NAS620-416

Tools Required: 3/16-inch Allen wrench  
Guide pins

Torque value for mounting hardware: 85-90 inch pounds

Weight of component: (maximum) 15 pounds  
Weight of mounting hardware: 0.1212 pounds

CHE Required: Restraint Harness, P/N 7904049-1  
Belt Assembly, P/N 7904070-3  
Transporter Bag, P/N 7904090-1

Pressurization Required: (Not applicable)

## TELEMETRY CALIBRATOR POWER AND CONTROL ASSEMBLY

Figure 1 Location: Panel 11 Callout 63

Manpower: 1 Technician

Mounting Hardware: Four 1/4-28 by 1-3/4 Screws, MS16998-48  
4 Washers, NAS620-416

Tools Required: 3/16-inch Allen wrench  
Guide pins

Torque value for mounting hardware: 85-90 inch pounds

Weight of component: (maximum) 5.3 pounds  
Weight of mounting hardware: 0.1260 pounds

CHE Required: Restraint Harness, P/N 7904049-1  
Belt Assembly, P/N 7915991-1  
Transporter Bag, P/N 7904090-1

Pressurization Required: (Not applicable)

---

## P1 PCM/RF TRANSMITTER ASSEMBLY

Figure 1 Location: Panel 11 Callout 62

Manpower: 2 Technicians

Mounting Hardware: Four 1/4-28 by 1-3/4 Screws, MS16998-48  
4 Washers, NAS620-416

Tools Required: 3/16-inch Allen wrench  
Guide pins

Torque value for mounting hardware: 85-90 inch pounds

Weight of component: (maximum) 19.5 pounds  
Weight of mounting hardware: 0.1260 pounds

CHE Required: Restraint Harness, P/N 7904049-1  
Belt Assembly, P/N 7904070-3  
Transporter Bag, P/N 7904090-1

Pressurization Required: 5.3 psig

## TELEMETRY CALIBRATOR

Figure 1 Location: Panel 11 Callout 64

Manpower: 1 Technician

Mounting Hardware: Four 1/4-28 by 1-3/4 Screws, MS16998-48  
4 Washers, NAS620-416

Tools Required: 3/16-inch Allen wrench  
Guide pins

Torque value for mounting hardware: 85-90 inch pounds

Weight of component: (maximum) 5.3 pounds  
Weight of mounting hardware: 0.1260 pounds

CHE Required: Restraint Harness, P/N 7904049-1  
Belt Assembly, P/N 7915991-1  
Transporter Bag, P/N 7904090 -1

Pressurization Required: (Not applicable)

---

## F1 RF TRANSMITTER ASSEMBLY

Figure 1 Location: Panel 12 Callout 69

Manpower: 2 Technicians

Mounting Hardware: Four 1/4-28 by 1-3/4 Screws, MS169998-48  
4 Washers, NAS620-416

Tools Required: 3/16-inch Allen wrench  
Guide pins

Torque value for mounting hardware: 85-90 inch pounds

Weight of component: (maximum) 19.5 pounds  
Weight of mounting hardware: 0.1260 pounds

CHE Required: Restraint Harness, P/N 7904049-1  
Belt Assembly, P/N 7904070-3  
Transporter Bag, P/N 7904090 -1

Pressurization Required: 5.3 psig

PCM/DDAS TELEMETER ASSEMBLY

Figure 1 Location: Panel 12 Callout 70

Manpower: 2 Technicians

Mounting Hardware: Four 1/4-28 by 1-3/4 Screws, MS16998-48  
4 Washers, NAS620-416

Tools Required: 3/16-inch Allen wrench  
Guide pins

Torque value for mounting hardware: 85-90 inch pounds

Weight of component: (maximum) 27 pounds  
Weight of mounting hardware: 0.1260 pounds

CHE Required: Restraint Harness, P/N 7904049-1  
Belt Assembly, P/N 7904070-3  
Transporter Bag, P/N 7904090-1

Pressurization Required: (Not applicable)

---

C-BAND TRANSPONDER

Figure 1 Location: Panel 12 Callout 71

Manpower: 1 Technician

Mounting Hardware: Four 1/4-28 by 1-3/4 Screws, MS16998-48 (501 Only)  
Four 1/4-28 by 1-1/2 Screws, MS16998-47 (201-212/502-515)  
4 Washers, NAS620-416

Tools Required: 3/16-inch Allen wrench  
Guide pins

Torque value for mounting hardware: 85-90 inch pounds

Weight of component: (maximum) 5.7 pounds  
Weight of mounting hardware: 0.1260 pounds

CHE Required: Restraint Harness, P/N 7904049-1  
Belt Assembly, P/N 7904070-5  
Transporter Bag, P/N 7904090-1

Pressurization Required: 5 psig

## 5 VOLT MEASURING VOLTAGE SUPPLY

Figure 1 Location: Panel 12 Callout 72

Manpower: 1 Technician

Mounting Hardware: Four 1/4-28 by 1-1/2 Screws, MS16998-47  
4 Washers, NAS620-416L

Tools Required: 3/16-inch Allen wrench  
Guide pins

Torque value for mounting hardware: 85-90 inch pounds

Weight of component: (approximate) 3.0 pounds  
Weight of mounting hardware: 0.108 pounds

CHE Required: Restraint Harness, P/N 7904049-1  
Belt Assembly, P/N 7904070-5  
Transporter Bag, P/N 7904090-1

Pressurization Required: (Not applicable)

---

## F1 TELEMETER ASSEMBLY

Figure 1 Location: Panel 12 Callout 73

Manpower: 2 Technicians

Mounting Hardware: Four 1/4-28 by 1-1/2 Screws, MS16998-47  
4 Washers, NAS620-416

Tools Required: 3/16-inch Allen wrench  
Guide pins

Torque value for mounting hardware: 85-90 inch pounds

Weight of component: (maximum) 17.5 pounds  
Weight of mounting hardware: 0.1128 pounds

CHE Required: Restraint Harness, P/N 7904049-1  
Belt Assembly, P/N 7904070-3  
Transporter Bag, P/N 7904090-1

Pressurization Required: (Not applicable)

## MEASURING DISTRIBUTOR

Figure 1 Location: Panel 13 Callout 67

Manpower: 2 Technicians

Mounting Hardware: Four 1/4-28 by 3-5/16 Screws, AN4-36A  
4 Washers, AN960-416

Tools Required: 7/16-inch socket  
Guide pins

Torque value for mounting hardware: 85-90 inch pounds

Weight of component: (approximate) 21 pounds  
Weight of mounting hardware: 0.0932 pounds

CHE Required: Restraint Harness, P/N 7904049-1  
Belt Assembly, P/N 7904070-1  
Transporter Bag, P/N 7904090-1

Pressurization Required: (Not applicable)

---

## MEASURING RACK A404

Figure 1 Location: Panel 13 Callout 68

Manpower: 2 Technicians

Mounting Hardware: Four 1/4-28 by 1-1/2 Screws, MS16998-47  
4 Washers, NAS620-416

Tools Required: 3/16-inch Allen wrench  
Guide pins

Torque value for mounting hardware: 85-90 inch pounds

Weight of component: (approximate) 21 pounds, with all module slots filled  
Weight of mounting hardware: 0.1128 pounds

CHE Required: Restraint Harness, P/N 7904049-1  
Belt Assembly, P/N 7904070-3  
Transporter Bag, P/N 7904090-1

Pressurization Required: (Not applicable)



## P1 PCM/RF TRANSMITTER ASSEMBLY

Figure 1 Location: Panel 13 Callout 74

Manpower: 2 Technicians

Mounting Hardware: Six 1/4-28 by 1-3/4 Screws, MS16998-48  
6 Washers, NAS620-416L

Tools Required: 3/16-inch Allen wrench  
Guide pins

Torque value for mounting hardware: 85-90 inch pounds

Weight of component: (maximum) 19.5 pounds  
Weight of mounting hardware: 0.1764 pounds

CHE Required: Restraint Harness, P/N 7904049-1  
Belt Assembly, P/N 7904070-3  
Transporter Bag, P/N 7904090-1

Pressurization Required: (Not applicable)

---

## TELEMETRY CALIBRATOR POWER AND CONTROL ASSEMBLY

Figure 1 Location: Panel 13 Callout 75

Manpower: 1 Technician

Mounting Hardware: Four 1/4-28 by 1-3/4 Screws, MS16998-48  
4 Washers, NAS620-416

Tools Required: 3/16-inch Allen wrench  
Guide pins

Torque value for mounting hardware: 85-90 inch pounds

Weight of component: (maximum) 5.3 pounds  
Weight of mounting hardware: 0.1260 pounds

CHE Required: Restraint Harness, P/N 7904049-1  
Belt Assembly, P/N 7915991-1  
Transporter Bag, P/N 7904090-1

Pressurization Required: (Not applicable)

PANELS 14 THRU 18  
REPLACEMENT DATA

## EDS DISTRIBUTOR

Figure 1 Location: Panel 14 Callout 66

Manpower: 2 Technicians

Mounting Hardware: Four 1/4-28 by 5-7/16 Screws, AN4-57A  
4 Washers, AN960-416L

Tools Required: 7/16-inch socket  
Guide pins

Torque value for mounting hardware: 85-90 inch pounds

Weight of component: (approximate) 34 pounds  
Weight of mounting hardware: 0.1316 pounds

CHE Required: Restraint Harness, P/N 7904049-1  
Belt Assembly, P/N 7904070-1  
Transporter Bag, P/N 7904090-1

Pressurization Required: (Not applicable)

---

## MEASURING RACK A408

Figure 1 Location: Panel 14 Callout 77

Manpower: 2 Technicians

Mounting Hardware: Four 1/4-28 by 1-1/2 Screws, MS16998-47  
4 Washers, NAS620-416

Tools Required: 3/16-inch Allen wrench  
Guide pins

Torque value of mounting hardware: 85-90 inch pounds

Weight of component: (approximate) 21 pounds, with all module slots filled  
Weight of mounting hardware: 0.1128 pounds

CHE Required: Restraint Harness, P/N 7904049-1  
Belt Assembly, P/N 7904070-3  
Transporter Bag, P/N 7904090-1

Pressurization Required: (Not applicable)

## TELEMETRY CALIBRATOR

Figure 1 Location: Panel 13 Callout 76

Manpower: 1 Technician

Mounting Hardware: Four 1/4-28 by 1-3/4 Screws, MS16998-48  
4 Washers, NAS620-416

Tools Required: 3/16-inch Allen wrench  
Guide pins

Torque value for mounting hardware: 85-90 inch pounds

Weight of component: (maximum) 5.3 pounds  
Weight of mounting hardware: 0.1260 pounds

CHE Required: Restraint Harness, P/N 7904049-1  
Belt Assembly, P/N 7915991-1  
Transporter Bag, P/N 7904090-1

Pressurization Required: (Not applicable)

---

## P1 PCM/RF TRANSMITTER ASSEMBLY

Figure 1 Location: Panel 13.Callout 79

Manpower: 2 Technicians

Mounting Hardware: Four 1/4-28 by 1-3/4 Screws, MS16998-48  
4 Washers, NAS620-416

Tools Required: 3/16-inch Allen wrench  
Guide pins

Torque value for mounting hardware: 85-90 inch pounds

Weight of component: (maximum) 15 pounds  
Weight of mounting hardware: 0.1260 pounds

CHE Required: Restraint Harness, P/N 7904049-1  
Belt Assembly, P/N 7904070-3  
Transporter Bag, P/N 7904090-1

Pressurization Required: 5.3 psig

## MEASURING RACK A407

Figure 1 Location: Panel 14 Callout 78

Manpower: 2 Technicians

Mounting Hardware: Four 1/4-28 by 1-1/2 Screws, MS16998-47  
4 Washers, NAS620-416

Tools Required: 3/16-inch Allen wrench  
Guide pins

Torque value of mounting hardware: 85-90 inch pounds

Weight of component: (approximate) 21 pounds, with all module slots filled  
Weight of mounting hardware: 0.1128 pounds

CHE Required: Restraint Harness, P/N 7904049-1  
Belt Assembly, P/N 7904070-3  
Transporter Bag, P/N 7904090-1

Pressurization Required: (Not applicable)

---

## CONTROL-EDS RATE GYROS

Figure 1 Location: Panel 15 Callout 82

Manpower: 2 Technicians

Mounting Hardware: Two 1/4-28 by 1-3/4 Screws, MS16998-48  
Two 1/4-28 by 2 Screws, MS16998-49  
4 Washers, NAS620-416L

Tools Required: 3/16-inch Allen wrench  
Guide pins

Torque value for mounting hardware: 85-90 inch pounds

Weight of component: (approximate) 10.5 pounds  
Weight of mounting hardware: 0.1278 pounds

CHE Required: Restraint Harness, P/N 7904049-1  
Belt Assembly, P/N 7904079-5  
Transporter Bag, P/N 7904090-1

Pressurization Required: 5.3 psig

## CONTROL SIGNAL PROCESSOR

Figure 1 Location: Panel 15 Callout 83

Manpower: 2 Technicians

Mounting Hardware: Six 1/4-28 by 1-1/4 Screws, MS16998-46 (204 Only)  
Six 1/4-28 by 1-1/2 Screws, MS16998-47 (205-212/501-515)  
6 Washers, NAS620-416L

Tools Required: 3/16-inch Allen wrench  
Guide pins

Torque value for mounting hardware: 85-90 inch pounds

Weight of component: (approximate) 38.5 pounds  
Weight of mounting hardware: 0.1422 pounds

CHE Required: Restraint Harness, P/N 7904049-1  
Belt Assembly, P/N 7904070-1  
Transporter Bag, P/N 7904090-1

Pressurization Required: 5.3 psig

---

## MEASURING RACK A409

Figure 1 Location: Panel 15 Callout 84

Manpower: 2 Technicians

Mounting Hardware: Four 1/4-28 by 1-1/2 Screws, MS16998-47  
4 Washers, NAS620-416

Tools Required: 3/16-inch Allen wrench  
Guide pins

Torque value for mounting hardware: 85-90 inch pounds

Weight of component: (approximate) 21 pounds, with all module slots filled  
Weight of mounting hardware: 0.1128 pounds

CHE Required: Restraint Harness, P/N 7904049-1  
Belt Assembly, P/N 7904070-3  
Transporter Bag, P/N 7904090-1

Pressurization Required: (Not applicable)

## MEASURING RACK A406

Figure 1 Location: Panel 15 Callout 85

Manpower: 2 Technicians

Mounting Hardware: Four 1/4-28 by 1-1/2 Screws, MS16998-47  
4 Washers, NAS620-416

Tools Required: 3/16-inch Allen wrench  
Guide pins

Torque value for mounting hardware: 85-90 inch pounds

Weight of component: (approximate) 21 pounds, with all module slots filled  
Weight of mounting hardware: 0.1128 pounds

CHE Required: Restraint Harness, P/N 7904049-1  
Belt Assembly, P/N 7904070-3  
Transporter Bag, P/N 7904090-1

Pressurization Required: (Not applicable)

---

## FLIGHT CONTROL COMPUTER

Figure 1 Location: Panel 16 Callout 86

Manpower: 4 Technicians

Mounting Hardware: Six 1/4-28 by 3/4 Screws, MS20004-4  
6 Washers, MS20002C4

Tools Required: 3/16-inch Allen wrench  
Guide pins

Torque value for mounting hardware: 85-90 inch pounds

Weight of component: (approximate) 140 pounds  
Weight of mounting hardware: 0.1260 pounds

CHE Required: Door Frame Assembly, P/N 7902257  
Top Channel Assembly, P/N 7902255  
Cart Assembly, P/N 7902170  
Hoist and Track Assembly, P/N 7902259  
2 Tube Assemblies, P/N 7902256  
Transporter and Adapter Assembly, P/N 7904080  
Flight Control Computer Fixture Assembly, P/N 7904046

Pressurization Required: 5.3 psig

Drain and Fill Procedure: Refer to Critical Components Drain and Fill  
Procedure 6-ILIU1B-260 or equivalent.

## SWITCH SELECTOR

Figure 1 Location: Panel 17 Callout 80

Manpower: 2 Technicians

Mounting Hardware: Four 1/4-28 by 1-1/2 Screws, MS16998-47  
4 Washers, NAS620-416L

Tools Required: 3/16-inch Allen head  
6-inch extension  
Guide pins

Torque value for mounting hardware: 85-90 inch pounds

Weight of component: (approximate) 19.8 pounds  
Weight of mounting hardware: 0.108 pounds

CHE Required: Restraint Harness, P/N 7904049-1  
Belt Assembly, P/N 7904070-3  
Transporter Bag, P/N 7904090-1

Pressurization Required: (Not applicable)

---

## REMOTE DIGITAL SUBMULTIPLEXER

Figure 1 Location: Panel 17 Callout 81

Manpower: 2 Technicians

Mounting Hardware: Four 1/4-28 by 1-3/4 Screws, MS16998-48  
4 Washers, NAS620-416

Tools Required: 3/16-inch Allen wrench  
Guide pins

Torque value for mounting hardware: 85-90 inch pounds

Weight of component: (maximum) 13.5 pounds  
Weight of mounting hardware: 0.1212 pounds

CHE Required: Restraint Harness, P/N 7904049-1  
Belt Assembly, P/N 7904070-3  
Transporter Bag, P/N 7904090-1

Pressurization Required: (Not applicable)



EDS TIMERS NO. 1, 2, AND 3 (40, 20, AND 60 SECONDS)

Figure 1 Location: No. 1 Panel 17 Callout 88  
No. 2 Panel 17 Callout 87  
No. 3 Panel 17 Callout 88

Manpower: 1 Technician

Mounting Hardware: Four 1/4-28 by 1-1/2 Screw, MS16998-47  
4 Washers, NAS620-416

Tools Required: 3/16-inch Allen wrench  
Guide pins

Torque value for mounting hardware: 85-90 inch pounds

Weight of component: (approximate) 0.6 pounds  
Weight of mounting hardware: 0.1128 pounds

CHE Required: None

Pressurization Required: (Not applicable)

---

COMMAND DIRECTIONAL COUPLER

Figure 1 Location: Panel 17 Callout 89

Manpower: 1 Technician

Mounting Hardware: Six 1/4-28 by 1-3/4 Screws, MS16998-48  
6 Washers, NAS620-416

Tools Required: 3/16-inch Allen wrench  
Guide pins

Torque value for mounting hardware: 40-45 inch pounds

Weight of component: (approximate) 0.7 pounds  
Weight of mounting hardware: 0.189 pounds

CHE Required: None

Pressurization Required: (Not applicable)

## COMMAND POWER DIVIDER

Figure 1 Location: Panel 17 Callout 90

Manpower: 1 Technician

Mounting Hardware: Four 1/4-28 by 1-3/4 Screws, MS16998-48  
4 Washers, NAS620-416

Tools Required: 3/16-inch Allen wrench  
Guide pins

Torque value for mounting hardware: 40-45 inch pounds

Weight of component: (maximum) 1 pound  
Weight of mounting hardware: 0.1212 pounds

CHE Required: None

Pressurization Required: (Not applicable)

---

## DDAS/COMPUTER INTERFACE UNIT

Figure 1 Location: Panel 17 Callout 92

Manpower: 2 Technicians

Mounting Hardware: Four 1/4-28 by 1-3/4 Screws, MS16998-48  
4 Washers, NAS620-416

Tools Required: 3/16-inch Allen wrench  
Guide pins

Torque value for mounting hardware: 85-90 inch pounds

Weight of component: (maximum) 15 pounds  
Weight of mounting hardware: 0.1212 pounds

CHE Required: Restraint Harness, P/N 7904049-1  
Belt Assembly, P/N 7904070-3  
Transporter Bag, P/N 7904090-1

Pressurization Required: (Not applicable)

## REMOTE DIGITAL MULTIPLEXER (J)

Figure 1 Location: Panel 17 Callout 91

Manpower: 2 Technicians

Mounting Hardware: Four 1/4-28 by 1-3/4 Screws, MS16998-48  
4 Washers, NAS620-416

Tools Required: 3/16-inch Allen wrench  
Guide pins

Torque value for mounting hardware: 85-90 inch pounds

Weight of component: (approximate) 13 pounds  
Weight of mounting hardware: 0.1212 pounds

CHE Required: Restraint Harness, P/N 7904049-1  
Belt Assembly, P/N 7904070-3  
Transporter Bag, P/N 7904090-1

Pressurization Required: (Not applicable)

---

## CCS HYBRID RING

Figure 1 Location: Panel 17 Callout 93

Manpower: 1 Technician

Mounting Hardware: Four 1/4-28 by 1-3/4 Screws, MS16998-48  
4 Washers, NAS620-416

Tools Required: 3/16-inch Allen wrench  
Guide pins

Torque value for mounting hardware: 40-45 inch pounds

Weight of component: (approximate) 1 pound  
Weight of mounting hardware: 0.1212 pounds

CHE Required: None

Pressurization Required: (Not applicable)

## CCS POWER DIVIDER

Figure 1 Location: Panel 17 Callout 94

Manpower: 1 Technician

Mounting Hardware: Two 1/4-28 by 1-3/4 Screws, MS16998-48  
2 Washers, NAS620-416

Tools Required: 3/16-inch Allen wrench  
Guide pins

Torque value for mounting hardware: 40-45 inch pounds

Weight of component: (approximate) 0.5 pounds  
Weight of mounting hardware: 0.0606 pounds

CHE Required: None

Pressurization Required: (Not applicable)

---

## CONTROL DISTRIBUTOR

Figure 1 Location: Panel 18. Callout 97

Manpower: 2 Technicians

Mounting Hardware: Four 1/4-28 by 5-7/16 Screws, AN4-57A  
4 Washers, AN960-416L

Tools Required: 7/16-inch socket  
Guide pins

Torque value for mounting hardware: 85-90 inch pounds

Weight of component: (approximate) 35 pounds  
Weight of mounting hardware: 0.1316 pounds

CHE Required: Restraint Harness, P/N 7904049-1  
Belt Assembly, P/N 7904070-1  
Transporter Bag, P/N 7904090-1

Pressurization Required: (Not applicable)

## COMMAND RECEIVER

Figure 1 Location: Panel 18 Callout 98

Manpower: 1 Technician

Mounting Hardware: Four 1/4-28 by 1-3/4 Screws, MS16998-48  
4 Washers, NAS620-416L

Tools Required: 3/16-inch Allen wrench  
Guide pins

Torque value for mounting hardware: 85-90 inch pounds

Weight of component: (maximum) 4 pounds  
Weight of mounting hardware: 0.1212 pounds

CHE Required: Restraint Harness, P/N 7904049-1  
Belt Assembly, P/N 7915991-1  
Transporter Bag, P/N 7904090-1

Pressurization Required: 14.3 psig

---

## SECURE RANGE SAFETY DECODER

Figure 1 Location: Panel 18 Callout 99

Manpower: 1 Technician

Mounting Hardware: Four 1/4-28 by 1-1/2 Screws, MS16998-47  
4 Washers, NAS620-416

Tools Required: 3/16-inch Allen wrench  
Guide pins

Torque value for mounting hardware: 85-90 inch pounds

Weight of component: (approximate) 4.7 pounds  
Weight of mounting hardware: 0.1128 pounds

CHE Required: Restraint Harness, P/N 7904049-1  
Belt Assembly, P/N 7904070-3  
Transporter Bag, P/N 7904090-1

Pressurization Required: 14.3 psig

## COMMAND DECODER

Figure 1 Location: Panel 18 Callouts 105 and 107

Manpower: 1 Technician

Mounting Hardware: Ten 1/4-28 by 1-3/4 Screws, MS16998-48  
10 Washers, NAS620-416L

Tools Required: 3/16-inch Allen wrench  
Guide pins

Torque value for mounting hardware: 85-90 inch pounds

Weight of component: (maximum) 7.5 pounds  
Weight of mounting hardware: 0.303 pounds

CHE Required: Restraint Harness, P/N 7904049-1  
Belt Assembly, P/N 7904070-5  
Transporter Bag, P/N 7904090-1

Pressurization Required: 14.3 psig

---

## REMOTE DIGITAL MULTIPLEXER (K)

Figure 1 Location: Panel 18 Callouts 100 and 106

Manpower: 2 Technicians

Mounting Hardware: Four 1/4-28 by 1-3/4 Screws, MS16998-48  
4 Washers, NAS620-416

Tools Required: 3/16-inch Allen wrench  
Guide pins

Torque value of mounting hardware: 85-90 inch pounds

Weight of component: (maximum) 15 pounds  
Weight of mounting hardware: 0.1212 pounds

CHE Required: Restraint Harness, P/N 7904049-1  
Belt Assembly, P/N 7904070-3  
Transporter Bag, P/N 7904090-1

Pressurization Required: (Not applicable)

PANELS 19 THRU 24  
REPLACEMENT DATA

## LAUNCH VEHICLE DATA ADAPTER

Figure 1 Location: Panel 19 Callout 96

Manpower: 4 Technicians

Mounting Hardware: Four 3/8-24 by 1-3/16 Screws, MS20006-8  
4 Washers, MS20002C6

Tools Required: 5/16-inch Allen wrench  
Guide pins, P/N IBM-SDD-22-26

Torque value for mounting hardware: 270 inch pounds maximum

Weight of component: (approximate) 190 pounds  
Weight of mounting hardware: 0.3292 pounds

CHE Required: Door Frame Assembly, P/N 7902257  
Top Channel Assembly, P/N 7902255  
Cart Assembly, P/N 7902170  
Hoist and Track Assembly, P/N 7902259  
2 Tube Assemblies, P/N 7902256  
Transporter and Adapter Assembly, P/N 7904080  
Launch Vehicle Data Adapter Fixture Assembly, P/N 7904033

Pressurization Required: 1.25 psig

Drain and Fill Procedure: Refer to Critical Components Drain and Fill  
Procedure 6-ILIU1B-260 or equivalent.



## LAUNCH VEHICLE DIGITAL COMPUTER

Figure 1 Location: Panel 19 Callout 101

Manpower: 4 Technicians

Mounting Hardware: Four 3/8-24 by 1-3/16 Screws, MS20006-8  
4 Washers, MS20002C6

Tools Required: 5/16-inch Allen wrench  
Guide pins, P/N IBM-SDD-22-40

Torque value for mounting hardware: 270 inch pounds maximum

Weight of component: (approximate) 80 pounds  
Weight of mounting hardware: 0.3292 pounds

CHE Required: Door Frame Assembly, P/N 7902257  
Top Channel Assembly, P/N 7902255  
Cart Assembly, P/N 7902170  
Hoist and Track Assembly, P/N 7902259  
2 Tube Assemblies, P/N 7902256  
Transporter and Adapter Assembly, P/N 7904080  
Launch Vehicle Digital Computer Fixture Assembly,  
P/N 7904050

Pressurization Required: 1.25 psig

Drain and Fill Procedure: Refer to Critical Components Drain and Fill  
Procedure 6-ILIU1B-260 or equivalent.

## ST-124M-3 PLATFORM ELECTRONIC ASSEMBLY

Figure 1 Location: Panel 20 Callout 95

Manpower: 4 Technicians

Mounting Hardware: Four 1/4-28 by 1-1/2 Screws, MS16998-47 (201-212/502-515)  
Four 1/4-28 by 1-3/4 Screws, MS16998-48 (501 Only)  
Ten 1/4-28 by 1-3/4 Screws, MS16998-48  
10 Washers, NAS620-416

Tools Required: 3/16-inch Allen wrench  
Guide pins

Torque value for mounting hardware: 85-90 inch pounds

Weight of component: (approximate) 50 pounds

Weight of mounting hardware: 0.4278 pounds

CHE Required: Door Frame Assembly, P/N 7902257  
Top Channel Assembly, P/N 7902255  
Cart Assembly, P/N 7902170  
Hoist and Track Assembly, P/N 7902259  
2 Tube Assemblies, P/N 7902256  
Transporter and Adapter Assembly, P/N 7904080  
ST-124M-3 Platform Electronic Assembly Fixture Assembly,  
P/N 7904056

Pressurization Required: 2 psig

---

## PLUG TYPE J-BOX ASSEMBLY

Figure 1 Location: Panel 20 Callout 102

Manpower: 1 Technician

Mounting Hardware: One 1/4-28 by 1-1/2 Screw, MS16998-47  
1 Washer, NAS620-416

Tools Required: 3/16-inch Allen wrench

Torque value for mounting hardware: 85-90 inch pounds

Weight of component: (approximate) 0.105 pounds

Weight of mounting hardware: 0.0282 pounds

CHE Required: None

Pressurization Required: (Not applicable)

## ST-124M-3 PLATFORM AC POWER SUPPLY

Figure 1 Location: Panel 20 Callout 103

Manpower: 2 Technicians

Mounting Hardware: Six 1/4-28 by 1-3/4 Screws, MS16998-48  
6 Washers, NAS620-416

Tools Required: 3/16-inch Allen wrench  
Guide pins

Torque value for mounting hardware: 85-90 inch pounds

Weight of component: (approximate) 30 pounds  
Weight of mounting hardware: 0.1890 pounds

CHE Required: Restraint Harness, P/N 7904049-1  
Belt Assembly, P/N 7904070-3  
Transporter Bag, P/N 7904090-1

Pressurization Required: 2 psig

---

## ACCELEROMETER SIGNAL CONDITIONER

Figure 1 Location: Panel 20 Callout 104

Manpower: 2 Technicians

Mounting Hardware: Four 1/4-28 by 1-3/4 Screws, MS16998-48 (201-212/502-515)  
Four 1/4-28 by 2 Screws, MS16998-49 (501 Only)  
4 Washers, NAS620-416

Tools Required: 3/16-inch Allen wrench  
Guide pins

Torque value for mounting hardware: 85-90 inch pounds

Weight of component: (approximate) 12 pounds  
Weight of mounting hardware: 0.1260 pounds

CHE Required: Restraint Harness, P/N 7904049-1  
Belt Assembly, P/N 7904070-5  
Transporter Bag, P/N 7904090-1

Pressurization Required: 2 psig

## CONTROL ACCELEROMETER (YAW)

Figure 1 Location: Panel 21 Callout 112

Manpower: 1 Technician

Mounting Hardware: Four #8-32 by 3/4 Screws, MS16997-34  
4 Washers, NAS620-8

Tools Required: 9/64-inch Allen wrench  
Guide pins

Torque value for mounting hardware: 85-90 inch pounds

Weight of component: (maximum) 5 pounds  
Weight of mounting hardware: (Not available)

CHE Required: Restraint Harness, P/N 7904049-1  
Belt Assembly, P/N 7915991-1  
Transporter Bag, P/N 7904090-1

Pressurization Required: (Not applicable)

---

## FORCE BALANCE ACCELEROMETERS

Figure 1 Location: Panel 21 Callout 113

Manpower: 2 Technicians

Mounting Hardware: Eight #10-32 by 5/8 Screws, MS16998-28  
8 Washers, NAS620-10L

Tools Required: 5/32-inch Allen wrench  
Guide pins

Torque value for mounting hardware: (Not available)

Weight of component: (Not available)  
Weight of mounting hardware: (Not available)

CHE Required: None

Pressurization Required: (Not applicable)

## ST-124M-3 INERTIAL PLATFORM ASSEMBLY

Figure 1 Location: Panel 21 Callout 114

Manpower: 4 Technicians

Mounting Hardware: To mount brackets

Five 1/4-28 by 3/4 Bolts, MS20004-4

5 Washers, 7915407-1

To mount platform to brackets

Two 1/2-20 by 15/16 Bolts, NAS1308-3H

Three 1/2-20 by 2-27/64 Bolts, NAS1308-27H

5 Washers, MS20002C8

5 Washers, 7914509-001

Tools Required: 3/16-inch Allen wrench

3/4-inch socket

Guide pins

Torque value for mounting hardware: 5 Bolts (MS20004-4), 85-90 inch pounds

2 Bolts (NAS1308), 100-150 inch pounds

3 Bolts (NAS1308-27H), 650-700 inch  
pounds

Weight of component: (approximate) 107 pounds

Weight of mounting hardware: (Not available)

CHE Required: Door Frame Assembly, P/N 7902257

Top Channel Assembly, P/N 7902255

Cart Assembly, P/N 7902170

Hoist and Track Assembly, P/N 7902259

2 Tube Assemblies, P/N 7902256

Transporter and Adapter Assembly, P/N 7904080

ST-124M-3 Inertial Platform Assembly Fixture Assembly,  
P/N 7904022

Pressurization Required: (Not applicable)

Drain and Fill Procedure: Refer to Critical Components Drain and Fill  
Procedure 6-ILIU1B-260 or equivalent.

## LOW PRESSURE SWITCH

Figure 1 Location: Panel 22 Callout 116

Manpower: 1 Technician

Mounting Hardware: Four 10-32 by 1-1/2 Screws, MS16998-33  
4 Washers, NAS620A10

Tools Required: 5/32-inch Allen wrench  
Guide pins

Torque value for mounting hardware: 85-90 inch pounds

Weight of component: (maximum) 0.48 pounds  
Weight of mounting hardware: 0.0753 pounds

CHE Required: None

Pressurization Required: (Not applicable)

---

## C-BAND TRANSPONDER

Figure 1 Location: Panel 23 Callout 108

Manpower: 1 Technician

Mounting Hardware: Four 1/4-28 by 1-3/4 Screws, MS16998-48 (501 Only)  
Four 1/4-28 by 1-1/2 Screws, MS16998-47 (201-212/502-515)  
4 Washers, NAS620-416

Tools Required: 3/16-inch Allen wrench  
Guide pins

Torque value for mounting hardware: 85-90 inch pounds

Weight of component: (maximum) 5.7 pounds  
Weight of Mounting hardware: 0.1260 pounds

CHE Required: Restraint Harness, P/N 7904049-1  
Belt Assembly, P/N 7904070-5  
Transporter Bag, P/N 7904090-1

Pressurization Required: 5 psig

## AZUSA RI FILTER ASSEMBLY

Figure 1 Location: Panel 23 Callout 109

Manpower: 2 Technicians

Mounting Hardware: Two 1/4-28 by 7/8 Screws, MS16998-44  
Two 1/4-28 by 1-3/4 Screws, MS16998-48  
4 Washers, NAS620-416

Tools Required: 3/16-inch Allen wrench  
Guide pins

Torque value for mounting hardware: 85-90 inch pounds

Weight of component: (approximate) 10 pounds  
Weight of mounting hardware: 0.1030 pounds

CHE Required: Restraint Harness, P/N 7904049-1  
Belt Assembly, P/N 7904070-5  
Transporter Bag, P/N 7904090-1

Pressurization Required: (Not applicable)

---

## AZUSA TRANSPONDER

Figure 1 Location: Panel 23 Callout 110

Manpower: 2 Technicians

Mounting Hardware: Four 1/4-28 by 2 Screws, MS16998-49  
4 Washers, NAS620-416

Tools Required: 3/16-inch Allen wrench  
Guide pins

Torque value for mounting hardware: 85-90 inch pounds

Weight of component: (approximate) 19 pounds  
Weight of mounting hardware: 0.1392 pounds

CHE Required: Restraint Harness, P/N 7904049-1  
Belt Assembly, P/N 7904070-3  
Transporter Bag, P/N 7904090-1

Pressurization Required: 1.3 psig

MEASURING RACK A669

Figure 1 Location: Panel 23 Callout 122

Manpower: 2 Technicians

Mounting Hardware: Four 1/4-28 by 1-1/2 Screws, MS16998-47  
4 Washers, NAS620-416

Tools Required: 3/16-inch Allen wrench  
Guide pins

Torque value for mounting hardware: 85-90 inch pounds

Weight of component: (approximate) 21 pounds, with all module slots filled  
Weight of mounting hardware: 0.1128 pounds

CHE Required: Restraint Harness, P/N 7904049-1  
Belt Assembly, P/N 7904070-3  
Transporter Bag, P/N 7904090-1

Pressurization Required: (Not applicable)

---

LATERAL ACCELEROMETER SLOSH, PITCH, AND YAW

Figure 1 Location: Panel 23 Callout 119

Manpower: 2 Technicians

Mounting Hardware: Four 1/4-28 by 1-3/4 Screws, MS16998-48  
4 Washers, NAS620-416

Tools Required: 3/16-inch Allen wrench  
Guide pins

Torque value for mounting hardware: 70-90 inch pounds

Weight of component: (approximate) 16.4 pounds  
Weight of mounting hardware: 0.1260 pounds

CHE Required: (Not available)

Pressurization Required: (Not available)



## LONGITUDINAL ACCELEROMETER ORBITAL LH<sub>2</sub> VENTING

Figure 1 Location: Panel 23 Callout 120

Manpower: 2 Technicians

Mounting Hardware: Six 1/4-28 by 1-3/4 Screws, MS16998-48  
6 Washers, NAS620-416

Tools Required: 3/16-inch Allen wrench  
Guide pins

Torque value for mounting hardware: 70-90 inch pounds

Weight of component: (approximate) 17.5 pounds  
Weight of mounting hardware: 0.189 pounds

CHE Required: (Not available)

Pressurization Required: (Not available)

---

## UHF/RF FILTER

Figure 1 Location: Panel 23 Callout 123

Manpower: 1 Technician

Mounting Hardware: Four 1/4-28 by 1-1/2 Screws, MS16998-48  
4 Washers, NAS620-416

Tools Required: 3/16-inch Allen wrench  
Guide pins

Torque value for mounting hardware: 85-90 inch pounds

Weight of component: (approximate) 8.0 pounds  
Weight of mounting hardware: 0.1212 pounds

CHE Required: Restraint Harness, P/N 7904049-1  
Belt Assembly, P/N 7904070-1  
Transporter Bag, P/N 7904090-1

Pressurization Required: (Not available)

## TV JUNCTION BOX

Figure 1 Location: Panel 24 Callout 6

Manpower: 1 Technician

Mounting Hardware: Four 1/4-28 by 1-1/2 Screws, MS16998-47  
4 Washers, AN960-416

Tools Required: 3/16-inch Allen wrench  
Guide pins

Torque value for mounting hardware: 85-90 inch pounds

Weight of component: (approximate) 1.5 pounds  
Weight of mounting hardware: 0.114 pounds

CHE Required: None

Pressurization Required: (Not applicable)

---

## TV POWER DIVIDER

Figure 1 Location: Panel 24 Callout 7

Manpower: 1 Technician

Mounting Hardware: Two 1/4-28 by 1-3/4 Screws, MS16998-48  
2 Washers, AN960-416

Tools Required: 3/16-inch Allen wrench  
Guide pins

Torque value for mounting hardware: 40-45 inch pounds

Weight of component: (approximate) 0.56 pounds  
Weight of mounting hardware: 0.0636 pounds

CHE Required: None

Pressurization Required: (Not applicable)

## TV POWER AMPLIFIER

Figure 1 Location: Panel 24 Callout 8

Manpower: 1 Technician

Mounting Hardware: Four 1/4-28 by 1-3/4 Screws, MS16998-48  
4 Washers, AN960-416

Tools Required: 3/16-inch Allen wrench  
Guide pins

Torque value for mounting hardware: 85-90 inch pounds

Weight of component: (approximate) 8.5 pounds  
Weight of mounting hardware: 0.114 pounds

CHE Required: Restraint Harness, P/N 7904049-1  
Belt Assembly, P/N 7904070-3  
Transporter Bag, P/N 7904090-1

Pressurization Required: 5 psig

## TV TRANSMITTER ASSEMBLY

Figure 1 Location: Panel 24 Callout 9

Manpower: 2 Technicians

Mounting Hardware: Four 1/4-28 by 1-1/2 Screws, MS16998-47  
Two 1/4-28 by 1-3/4 Screws, MS16998-48  
6 Washers, AN960-416

Tools Required: 3/16-inch Allen wrench  
Guide pins

Torque value for mounting hardware: 70-90 inch pounds

Weight of component: (approximate) 28 pounds  
Weight of mounting hardware: 0.1926 pounds

CHE Required: Restraint Harness, P/N 7904049-1  
Belt Assembly, P/N 7904070-1  
Transporter Bag, P/N 7904090-1

Pressurization Required: 5 psig

## CAMERA CONTROL UNIT (GEC)

Figure 1 Location: Panel 24 Callouts 10 and 19

Manpower: 1 Technician

Mounting Hardware: Six 1/4-28 by 1-3/4 Screws, MS16998-48  
6 Washers, AN960-416

Tools Required: 3/16-inch Allen wrench

Torque value for mounting hardware: 85-90 inch pounds

Weight of component: (approximate) 8.25 pounds  
Weight of mounting hardware: 0.1908 pounds

CHE Required: Restraint Harness, P/N 7904049-1  
Belt Assembly, P/N 7904070-3  
Transporter Bag, P/N 7904090-1

Pressurization Required: (Not applicable)

---

## CCS TRANSPONDER

Figure 1 Location: Panel 24 Callout 21

Manpower: 1 Technician

Mounting Hardware: Six 1/4-28 by 2 Screws, MS16998-49  
6 Washers, NAS620-416

Tools Required: 3/16-inch Allen wrench  
Guide pins

Torque value for mounting hardware: 85-90 inch pounds

Weight of component: (maximum) 21.5 pounds  
Weight of mounting hardware: 0.2088 pounds

CHE Required: Restraint Harness, P/N 7904049-1  
Belt Assembly, P/N 7904070-1  
Transporter Bag, P/N 7904090-1

Pressurization Required: 5 psig

## CCS POWER AMPLIFIER

Figure 1 Location: Panel 24 Callout 22

Manpower: 2 Technicians

Mounting Hardware: Eight 1/4-28 by 1-1/2 Screws, MS16998-47  
8 Washers, NAS610-416

Tools Required: 3/16-inch Allen wrench  
Guide pins

Torque value for mounting hardware: 85-90 inch pounds

Weight of component: (maximum) 20 pounds  
Weight of mounting hardware: 0.2256 pounds

CHE Required: Restraint Harness, P/N 7904049-1  
Belt Assembly, P/N 7904070-3  
Transporter Bag, P/N 7904090-1

Pressurization Required: 5 psig

---

## UHF/RF TRANSMITTER ASSEMBLY

Figure 1 Location: Panel 24 Callout 23

Manpower: 2 Technicians

Mounting Hardware: Four 1/4-28 by 1-3/4 Screws, MS16998-48  
4 Washers, 7915826-001

Tools Required: 3/16-inch Allen wrench  
Guide pins

Torque value for mounting hardware: 85-90 inch pounds

Weight of component: (approximate) 11 pounds  
Weight of mounting hardware: 0.1212 pounds

CHE Required: Restraint Harness, P/N 7904049-1  
Belt Assembly, P/N 7904070-3  
Transporter Bag, P/N 7904090-1

Pressurization Required: 5.3 psig

## PCM COAXIAL SWITCH

Figure 1 Location: Panel 24 Callout 24

Manpower: 1 Technician

Mounting Hardware: Six 1/4-28 by 1-1/2 Screws, MS16998-47  
6 Washers, NAS620-416

Tools Required: 3/16-inch Allen wrench  
Guide pins

Torque value for mounting hardware: 85-90 inch pounds.

Weight of component: (approximate) 0.5 pounds  
Weight of mounting hardware: 0.1692 pounds

CHE Required: None

Pressurization Required: (Not applicable)

---

## CCS COAXIAL SWITCH

Figure 1 Location: Panel 24 Callout 25

Manpower: 1 Technician

Mounting Hardware: Six 1/4-28 by 1-1/2 Screws, MS16998-47  
6 Washers, NAS620-416

Tools Required: 3/16-inch Allen wrench  
Guide pins

Torque value for mounting hardware: 85-90 inch pounds

Weight of component: (approximate) 0.5 pounds  
Weight of mounting hardware: 0.1692 pounds

CHE Required: None

Pressurization Required: (Not applicable)

## S-BAND POWER AMPLIFIER

Figure 1 Location: Panel 24 Callouts 16 and 18

Manpower: 2 Technicians

Mounting Hardware: Four 1/4-28 by 1-3/4 Screws, MS16998-48  
4 Washers, NAS620-416

Tools Required: 3/16-inch Allen wrench  
Guide pins

Torque value for mounting hardware: 85-90 inch pounds

Weight of component: (approximate) 12 pounds  
Weight of mounting hardware: 0.1212 pounds

CHE Required: Restraint Harness, P/N 7904049-1  
Belt Assembly, P/N 7904070-3  
Transporter Bag, P/N 7904090-1

Pressurization Required: (Not applicable)

---

## EXCITER UNITS

Figure 1 Location: Panel 24 Callout 17

Manpower: 1 Technician

Mounting Hardware: Bottom Unit, Four 1/4-28 by 1-1/2 Screws, MS16998-47  
4 Washers, NAS620-416  
Top Unit, Four 1/4-28 by 1 Screws, MS16998-45  
4 Washers, NAS620-416

Tools Required: 3/16-inch Allen wrench  
Guide pins

Torque value for mounting hardware: 85-90 inch pounds

Weight of component: (Not available)  
Weight of mounting hardware: 0.1992 pounds

Pressurization Required: (Not available)

CAMERA CONTROL UNIT (KINTEL)

Figure 1 Location: Panel 24 Callout 20

Manpower: 1 Technician

Mounting Hardware: Four 1/4-28 by 1-1/2 Screws, MS16998-47  
4 Washers, NAS620-416

Tools Required: 3/16-inch Allen wrench  
Guide pins

Torque value for mounting hardware: 85-90 inch pounds

Weight of component: (approximate) 8.0 pounds  
Weight of mounting hardware: 0.1128 pounds

CHE Required: Restraint Harness, P/N 7904049-1  
Belt Assembly, P/N 7904070-3  
Transporter Bag, P/N 7904090-1

Pressurization Required: (Not applicable)



## IU TECHNICAL MANUAL AND RELATED DOCUMENTS LIST

TITLE	NUMBER	SOURCE *
INSTRUMENT UNIT		
COMPONENT HANDLING EQUIPMENT DESCRIPTION AND OPERATING INSTRUCTIONS	66-966-0005	1
OPERATION AND MAINTENANCE INSTRUCTIONS, HEAT SUBSTITUTE CART PART NO. 85Z06676	67-966-0001	1
Instrument Unit General Test Plan	67-257-0001	5
System Equipment Functional Block Diagrams, Saturn IB/V	66-256-0003	5
Instrument Unit Apollo Saturn AS-200 and AS-500 Series		
System Functional Interconnection Diagram		
AS-201	65-208-0002H	5
AS-202	65-256-0001H	5
AS-203	65-256-0003H	5
AS-204	65-256-0006H	5
AS-205	66-256-0004	5
AS-206	66-256-0005	5
AS-207	66-256-0006	5
AS-208	66-256-0010	5
AS-501	66-256-0002H	5
AS-502	66-256-0008	5
AS-503	66-256-0007	5
AS-504	66-256-0009	5

TITLE	NUMBER	SOURCE*
APOLLO-SATURN VEHICLES		
ASTRONICS SYSTEM HANDBOOK, SATURN LAUNCH VEHICLES	-----	1
EMERGENCY DETECTION SYSTEM DESCRIPTION (200 SERIES)	66-966-0010	1
EMERGENCY DETECTION SYSTEM DESCRIPTION (500 SERIES)	66-966-0022	1
EDS Q-BALL SENSOR ASSEMBLY (50Z12580)	66-966-0027	1
STRUCTURAL SYSTEM		
STRUCTURE REPAIR MANUAL	66-966-0011	1
UMBILICAL SATURN IB	67-966-0004	1
UMBILICAL SATURN V	67-966-0005	1
ELECTRICAL SYSTEM		
AUXILIARY POWER DISTRIBUTORS**	66-966-0013H	1
Auxiliary Power Distributor Qualification Test Report	66-226-0019	5
BATTERY (S-IU-201 THRU 212/501 THRU 515)	66-966-0024	1
CONTROL DISTRIBUTOR**	65-966-0016H	1
Control Distributor Qualification Test Report	66-226-0017	5
EMERGENCY DETECTION SYSTEM DISTRIBUTOR**	65-966-0015H	1
EDS Distributor Qualification Test Report	66-226-0018	5
J-Box Assembly Qualification Test Report	66-226-0011	5
MEASURING DISTRIBUTORS**	65-966-0017H	1
Measuring Distributor Qualification Test Report	66-226-0020	5
POWER DISTRIBUTOR**	65-966-0014H	1
Power Distributor Qualification Test Report	66-226-0016	5
Network Cables Qualification Test Report	66-226-0013	5
S-IU-501 Batteries Qualification Test Report	67-F01-0001	5
Switch Selector Mod I	50M04008	3
SWITCH SELECTOR MOD II	66-966-0001	1
Switch Selector Mod II, Worst Case Analysis	65-294-0001H	5
5 VOLT MEASURING VOLTAGE SUPPLY	65-966-0019H	1
5-Volt Measuring Voltage Supply Qualification Test Report	66-226-0014	5
40-Second Timer Qualification Test Report	66-226-0012	5
56 VOLT POWER SUPPLY	65-966-0018H	1
56-Volt Power Supply Qualification Test Report	66-226-0015	5
**These manuals are at the S-IU-201 level. No plans exist to update their contents to later vehicle configurations.		

TITLE	NUMBER	SOURCE*
ENVIRONMENTAL CONTROL SYSTEM		
Contact Chatter Vibration Test of Pressure Switches	67-242-0008	5
Differential Pressure Transducer Qualification Test Report	67-245-0008	5
ENVIRONMENTAL CONTROL SYSTEM DESCRIPTION	66-966-0009	1
Flexible Hose Assemblies Qualification Test Report	67-966-0006	5
Gas Bearing Heat Exchanger Qualification Test Report	67-K83-0002	5
IU Heaters Qualification Test Report	67-F02-0001	5
Machined Methanol/Water Accumulator Qualification Test Report	67-K83-0003	5
Quick Disconnect Coupling Qualification Test Report	66-226-0024	5
Water/Methanol Accumulator Qualification Test Report	66-K83-0001	5
20-Micron Filter Qualification Test Report	67-K83-0001	5
165-Cubic-Inch Sphere Qualification Test Report	66-226-0032	5
GUIDANCE CONTROL SYSTEM		
CONTROL ACCELEROMETER	66-966-0012	1
Control Active Filter Synthesis and Worst Case Analysis, Saturn V	66-280-0002	5
Control Computer 12MA Servo Magnetic Amplifier, Noise Investigation	66-280-0001	5
CONTROL-EDS RATE GYRO PACKAGE	66-966-0013	1
CONTROL SIGNAL PROCESSOR	66-966-0014	1
FLIGHT CONTROL COMPUTER (AS-203)	66-966-0015	1
FLIGHT CONTROL COMPUTER (200 SERIES)	66-966-0021	1
FLIGHT CONTROL COMPUTER (500 SERIES)	66-966-0025	1
Final Flight Simulation Report for AS-205 Flight Control Computer No. 0101	Not Avail.	
Launch Vehicle Data Adapter, Volumes I and II	NASA No. 50M35011 IBM No. 66112050, 6112070, 6139200, 6139800, 6139400	1
Launch Vehicle Digital Computer, Volumes I and II	NASA No. 50M35010 IBM No. 6112050, 6112070, 6139200, 6139800	1

TITLE	NUMBER	SOURCE*
LVDA, LVDC Vibration Isolation Qualification Test Report	67-K80-0001	5
NAVIGATION, GUIDANCE, AND CONTROL SYSTEM DESCRIPTION	66-966-0003	1
Passive Filter Network Analyses Worst Case, Saturn 501	66-280-0003	5
Retroreflector Assembly Qualification Test Report	66-210-0002	5
ST-124M Inertial Platform System, NASA Technical Note	NASA TND-2983	2
ST-124M/LVDA Resolver System, Error Analysis of	65-208-0074	5
ST-124M Mounting Frame Qualification Test Report	66-K80-0009	5
TEST REFERENCE MANUAL, SATURN IB/V REFERENCE MANUAL	66-966-0004	1
Volume I - Control System		
Volume II - Guidance System		
Volume III - ST-124M-3 Inertial Stabilizer System		
Worst Case Analysis of 45-Volt DC Amplifier	66-280-0006	5
50 Ma Servo Amplifier Interface Study & Worst Case Analysis	67-280-0001	5

#### MEASURING AND TELEMETRY SYSTEM

Computer Interface Unit Mod 501 Maintenance and Instruction Manual	50M66520	3
Instrumentation Program and Components Lists		
S-IU-201	50M12020	3
S-IU-202	50M12030	3
S-IU-203	50M12393	3
S-IU-204	50M12394	3
S-IU-205	6009039	3
S-IU-206	6009040	3
S-IU-207	6009041	3
S-IU-208	6009042	3
S-IU-209	6009043	3
S-IU-210	6009044	3
S-IU-211	6009045	3
S-IU-212	6009046	3
S-IU-501	50M10670	3
S-IU-502	6009047	3
S-IU-503	6009048	3
S-IU-504	6009049	3
S-IU-505	6009050	3
S-IU-506	6009051	3

TITLE	NUMBER	SOURCE *
Instrumentation Program and Components Lists (Cont)		
S-IU-507	6009052	3
S-IU-508	6009053	3
S-IU-509	6009054	3
S-IU-510	6009055	3
S-IU-511	6009056	3
S-IU-512	6009057	3
S-IU-513	6009058	3
S-IU-514	6009059	3
S-IU-515	6009060	3
Instrumentation Systems Description, Saturn IB	60C0975	3
SA-201 thru 205		
Inter-Range Instrumentation Group (IRIG) Telemetry Standards	106-65	4
MEASURING AND TELEMETRY SYSTEM DESCRIPTION	67-966-0008	1
MEASURING RACK AND MEASURING RACK SELECTOR	66-966-0017	1
Multiplexer Mod 245, Maintenance Instructions	50M66509	3
PCM/RF Assembly Mod CT-19B, Maintenance Instructions	50M66514	3
PCM/DDAS Model 301, Subsystem Assembly Maintenance Instructions	50M66512	3
Remote Digital Multiplexer Mod 410 Maintenance and Instruction Manual	50M66519	3
Remote Digital Submultiplexer, Maintenance Instructions	50M66513	3
Radio Frequency Assembly Mod I, Maintenance and Instruction Manual	50M66505	3
RF Assembly (Analog) Mod II Maintenance and Instruction Manual	50M66515	3
RF Assembly (Digital) Mod II Maintenance and Instruction Manual	50M66516	3
Saturn Telemetry Post-Flight Analysis Report	Not Avail.	
SS/FM Telemetry Assembly, Maintenance and Instruction Manual	50M66510	3
SS/FM Top Deck Assembly Maintenance Instructions	50M66511	3
Tape Recorder Mod 101	50M66517	3
Tape Recorder Mod 101 Maintenance and Instruction Manual	50M66504	3
Telemetry Calibrator Mod II, Maintenance and Instruction Manual	50M66508	3
Telemetry Calibrator Power and Control Assembly	50M66521	3
Telemetry Directional Coupler Assembly Qualification Test Report	67-223-0003	5
Telemetry Oscillator Assembly Models A1, A2, and A3, Maintenance and Instruction Manual	50M66501	3
Telemetry Oscillator Assembly Mod B1 Maintenance and Instruction Manual	50M66503	3
Telemetry Power Divider Qualification Test Report	67-235-0007	5
Time Division Multiplexer Mod 270 Maintenance Instructions	50M66506	3
TM Antenna Qualification Test Report	67-235-0006	5
VSWR Measuring Assembly Qualification Test Report	67-235-0008	5

TITLE	NUMBER	SOURCE *
RADIO FREQUENCY SYSTEM		
Antenna Systems (SA-202)	60C0958	3
Azusa Antenna Qualification Test Report	67-235-0004	5
Azusa Type C Transponder Assembly Model 26-52 Maintenance and Instruction Manual	-----	3
C-Band Antenna Qualification Test Report	67-235-0005	5
C-BAND RADAR TRANSPONDER SET SST-135C	66-966-0008	1
C-BAND RADAR TRANSPONDER SET SST-135C (S-IU-204) THRU 212/501 THRU 515)	66-966-0020	1
C-Band Transponder Qualification Test Report	67-235-0010	5
CCS Omnidirectional Receiving Antenna Qualification Test Report	67-223-0002	5
CCS Omnidirectional Transmitting Antenna Qualification Test Report	67-223-0004	5
CCS POWER AMPLIFIER	67-966-0002	1
CCS Power Divider Qualification Test Report	67-223-0001	5
CCS TRANSPONDER	67-966-0003	1
Command Antenna Qualification Test Report	67-235-0003	5
COMMAND DECODER (S-IU-204 THRU 212/501 THRU 515)	66-966-0019	1
Command Decoder Qualification Test Report	67-235-0009	5
Command Directional Coupler Qualification Test Report	67-235-0002	5
Command Power Divider Qualification Test Report	67-235-0001	5
COMMAND RECEIVER	67-966-0014	1
Command Receiver Checkout Manual	50M60161	3
COMMAND SYSTEM DESCRIPTION	67-966-0007	1
Math Model Program for Predicting Interference Frequencies and their Amplitude	Not Avail.	5
Radio Frequency System Manual	60C09036A	3
Range Safety Decoder Checkout Manual	50M60157-A	3
Unified S-Band Telecommunications Techniques for Apollo, Volume 1 - Functional Descriptions, NASA Technical Note	NASA TND-2208	2
Unified S-Band Technical Conference, Proceedings of	NASA SP-87	2

\* Details on the availability of these documents may be obtained from the following sources:

1. See Note 1  
Technical Manual Distribution  
Department 966  
IBM Corporation  
Federal Systems Division  
P.O. Box 1250  
Huntsville, Alabama, 35807
2. See Note 2  
Scientific and Technical Information Division  
National Aeronautics and Space Administration  
Washington, D.C., 20546
3. Marshall Space Flight Center  
Technical Documentation Repository Branch  
MS-D Building 4746  
Huntsville, Alabama
4. See Note 2  
Armed Services Technical Information Agency  
Arlington Hall Station  
Arlington 12, Virginia
5. Library  
IBM Corporation  
Federal Systems Division  
P.O. Box 1250  
Huntsville, Alabama, 35807

- Notes:
1. All requests for documents coded 1 should be made using Form 955-0924 if the requester is located at IBM Huntsville.
  2. All requests for documents coded 2 and 4 shall be made to source 5 if the requester is located at IBM Huntsville.
  3. All titles typed in upper-case letters represent technical manuals prepared by Department 966 at IBM Huntsville.