



NATIONAL AERONAUTICS & SPACE ADMINISTRATION
GEORGE C. MARSHALL SPACE FLIGHT CENTER



SATURN I SUMMARY

SATURN HISTORY DOCUMENT
University of Alabama Research Institute
History of Science & Technology Group

Date ----- Doc. No. -----



The fifth Saturn I vehicle rises from its launch pad.

44p. N66-23597 TM 57401

A PROLOGUE TO SATURN...



A medieval notion of the structure of the cosmos led to this concept of space exploration.

Nobody knows precisely when the dream of space travel first started. By A.D. 160, at least one fictional account concerning a voyage to the Moon had been written, demonstrating that the concept of traveling from one heavenly body to another is over 1800 years old. For centuries thereafter, the only recorded ideas of journeys into space were fanciful tales, wherein voyagers traversed the skies on muscle-powered, flapping wings attached to their bodies, drove flying chariots with unspecified or supernatural means of lift and propulsion, or inveigled rides with angels, demons, or birds.

Except for a lucky guess by Cyrano de Bergerac, a Seventeenth Century poet and writer, who suggested the use of a box with large numbers of black-powder rockets attached as a vehicle for reaching the Moon, no authors came close to guessing how one could truly travel in space. Not until the end of the Nineteenth Century did technology advance far enough for serious thought to be directed toward space travel. Even then, the work of pioneer rocketeers in the United States, Russia, and Germany on space flight was generally considered to be crackpot or harebrained by the average man, to whom the space rocket remained a science-fiction or comic-book concept until the advent of the V-2 rocket in the closing phases of World War II.



Under the impression that the sun "draws up" dewdrops, Cyrano de Bergerac suggested fancifully that one might fly by trapping dew in bottles, strapping the bottles to oneself, and standing in the sunlight.

would lead to the Saturn program. Months before the launching of Sputnik I, it was already clear to many leading space scientists that the space program of the United States had to have large vehicles designed purely for space applications. In December of 1957, before the first American satellite was launched successfully, a proposal for a program for the creation of a rocket booster having a thrust of 1,500,000 pounds was forwarded to the Department of Defense. The Department of Defense approved the project on August 15, 1958, and named it Juno V. The rocket later was renamed Saturn, in February of 1959. It was named Saturn because Saturn is the next planet farther from the sun than Jupiter, and the name was in keeping with the tradition of naming rockets after Greek and Roman gods.

After the war, there was accelerated rocket research in several countries, much of it built upon the firings of captured V-2s. This led to more talk about space flight. During this stage, rocket research for space flight was no longer considered so much hare-brained as possible, but impractical.

Although more and more engineers and scientists were computing and planning various possible space projects, it was not until July 29, 1955, that the United States had an official space program--the launching of an artificial earth satellite within and as a part of the International Geophysical Year (IGY).

By April of 1957, the Development Operations Division of the Army Ballistic Missile Agency (ABMA), headed by Dr. Wernher von Braun, began studies that



During the early introduction of rockets to Europe, they were used only as weapons.

火箭

The origin of the rocket is told simply in these Chinese characters. They stand for both "rocket" and "fire arrow."

2/15/66



At the beginning of the 20th Century, the Russian rocket pioneer Konstantin E. Tsiolkovski published scientific papers on rocketry and space travel. His earliest dealt with liquid-fuel rockets. Curiously, the Russian scientists of this time neither ridiculed nor praised him. They greeted his papers with total indifference.

There were two schools of thought on the development of rocket programs at that time. One school suggested that a completely new design be made for each space vehicle type. The other school suggested the more evolutionary approach of modifying existing design to produce new vehicles that would be based upon proven engineering principles.

In the Saturn program, it was decided to use components modified from already-available equipment. This off-the-shelf hardware concept had paid dividends in our early Explorer and Pioneer launches, and its application to the Saturn program was natural. For example, the engines for what became the Saturn booster were to be improved and uprated versions of an engine that was used in the Jupiter and Thor missiles, and the propellant containers would be modified from existing types of tankage used in the Redstone and Jupiter boosters.

What was to become the Saturn I rocket evolved from earlier rockets. Its phenomenal success rate can be attributed in large part to this design concept.

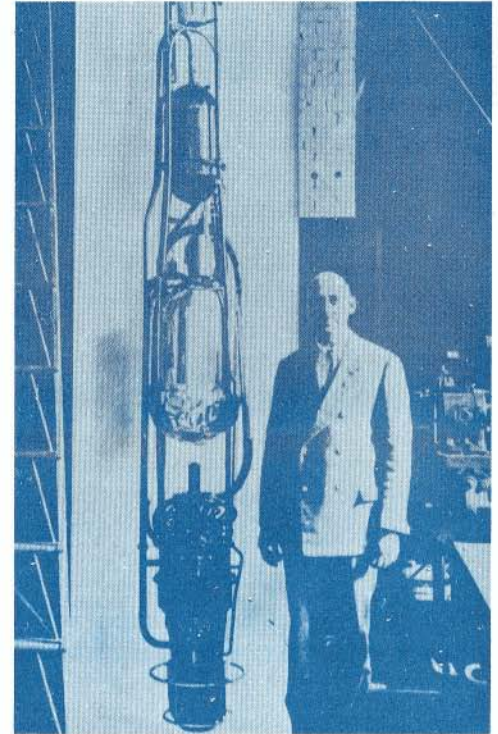

Dr. Robert H. Goddard, the father of modern rocketry. Dr. Goddard invented the first liquid-propellant rocket to fly; he launched it in 1926 at Auburn, Massachusetts. Pictured here is one of his later rockets, developed in his laboratory at Roswell, New Mexico.

THE SATURN PROGRAM...

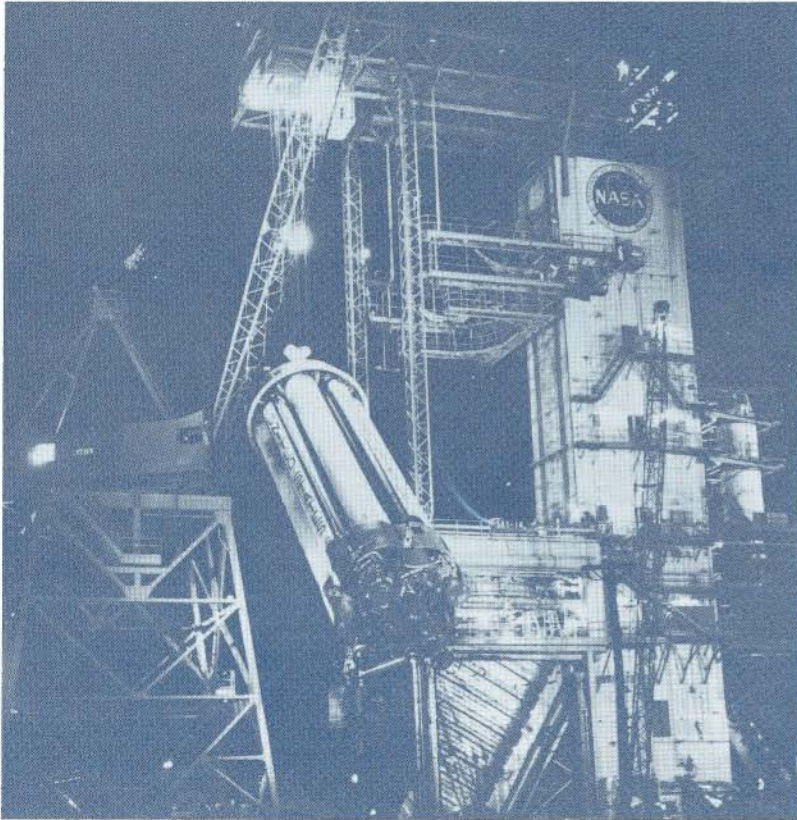

The first Saturn S-I stage being installed in the static test tower at MSFC. Here the rocket underwent captive firing tests to insure reliable performance.

Finished ideas grow from simple concepts. Originally, the Saturn booster program was initiated just to develop the technology of large-thrust vehicles. It was reasoned that by utilizing hardware from existing systems, and modifying it as necessary, a new rocket of the desired thrust could be developed that would be both reliable and relatively inexpensive.

However, it was realized even then that building a booster stage alone to prove a principle would not be enough. The personnel on the program were therefore requested by the Advanced Research Projects Agency (ARPA) to study a complete vehicle system, so that upper stages could be selected and developed for use with the booster stage. At the same time, studies on launching facilities for such vehicles were initiated.

The results of the initial studies indicated that existing rockets, such as the Atlas or the Titan, would be adaptable for use on the booster; however, these studies, while complete in themselves, were still but a beginning.

By 1959, the space goals of the United States were becoming firmer. And as design and development of the Saturn booster progressed, it was becoming more evident that a large-thrust stage of this sort would be

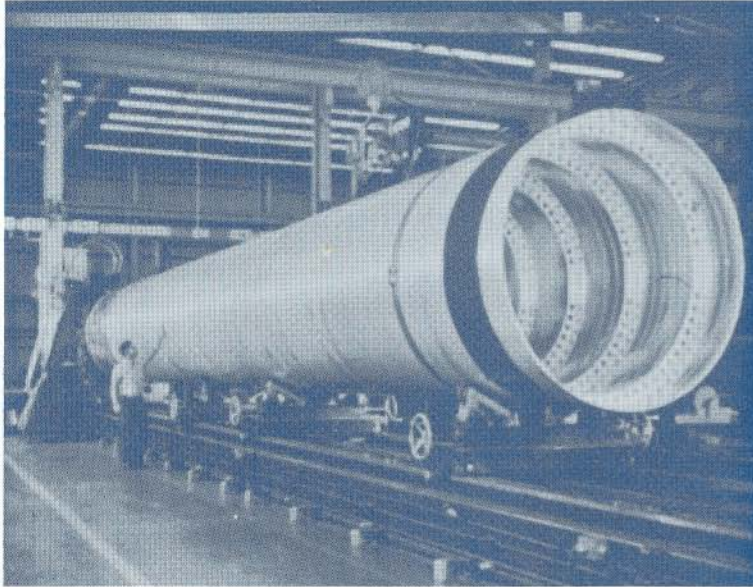

An engineer inspects a modified Redstone tank, used in the S-1 stage. The completed stage had eight such tanks clustered around a larger central tank.

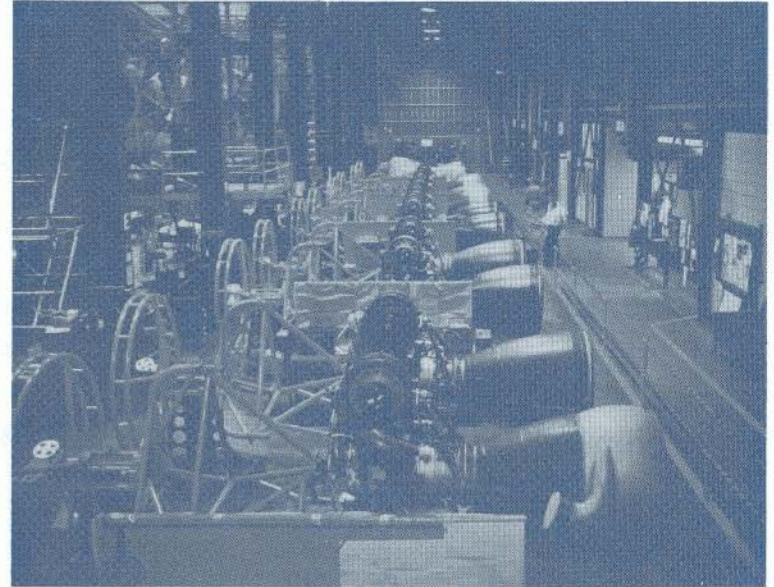

The H-1 engines, manufactured by Rocketdyne for the first stage of the Saturn I rocket, dwarf the engineers at the assembly area in MSFC.

most useful as part of a vehicle for the National Aeronautics and Space Administration (NASA). Dr. Abe Silverstein of NASA, with both NASA and Department of Defense approval, recommended a long-range development plan for Saturn. It was agreed that all upper stages of the early family of Saturn vehicles should use liquid hydrogen and liquid oxygen as propellants because of the high energy available with this combination.

Working under direction from ARPA, ABMA completed by the end of the year a study design for the overall Saturn vehicle configurations. This design, based on the concept of using flight-proven hardware to the maximum, also included the capability of carrying NASA payloads.



The static test of an early S-I stage as seen from an observation plane. The flame of the exhaust is deflected by a water-cooled scoop at the base of the tower.

Also by the end of 1959, a ten-vehicle research and development program was established as a part of the overall program, with the tenth vehicle scheduled to be the prototype for the operational vehicle. Anticipating a formal transfer announced by President Eisenhower, NASA assumed technical direction of the Saturn program in November. It was now clear that Saturn was to play an extensive part in our civilian space program.

The original concept of the Saturn vehicle, called C-1, was a three-stage rocket. The first stage was to be the 1,500,000-pound-thrust stage already under development. This stage, designated as the S-I, would use the already-proven combination of kerosene and liquid oxygen for fuel. The second stage, named the S-IV, was planned to use a

propellant combination of liquid hydrogen and liquid oxygen, one of the most powerful combinations of propellants possible in liquid-fuel rocket technology. The initial plans called for this stage to have four engines producing a total combined thrust of 80,000 pounds. The third stage, designated the S-V, was also to use liquid hydrogen and liquid oxygen as propellants, and was to have two engines of the same kind as used in the S-IV stage. The S-V stage was planned to have a thrust of 40,000 pounds.

While the booster design was being tested, a contract had been awarded to Douglas Aircraft Company for the design and development of a second stage for the rocket, the S-IV stage.

The official dedication of the George C. Marshall Space Flight Center (MSFC), the NASA facility at Huntsville, Alabama, took place on September 8, 1960. In an executive order, President Eisenhower named the facility after General Marshall, noting that the Center was expected to play a major part in the space programs of the United States.

Studies had been initiated for the proposed third stage, the S-V, and also for the possible use of the rocket as a part of the project to land astronauts on the Moon. As a result of these studies and other considerations, NASA approved use of the Saturn C-1 vehicle, in a two-stage configuration, for launching multi-ton earth-orbital Apollo payloads.

The Saturn concept was evolving. A requirement to demonstrate large-thrust capability had grown into a program for a vehicle with a specific mission, as a part of a great overall program of United States space exploration. But, though the mission and the vehicle type were now defined, much work remained to be done.

Studies therefore continued. Research work on the proposed liquid hydrogen engine determined that an engine already being developed for another rocket program (Centaur) would meet Saturn requirements. NASA headquarters approved



A completed early Saturn, "horizontally mated," seen next to a Redstone and a Jupiter vehicle.

the use of six RL-10 first-generation Centaur engines, built by Pratt & Whitney, in a cluster instead of the four engines originally scheduled for development for the S-IV stage.

In April of 1961, the first static firing test for flight qualification of an S-I stage took place. The results of this test were successful. And even as the first of the stages was being tested, the second one was being constructed.

GROWTH AND DEVELOPMENT

In May of 1961, NASA Headquarters approved the design changes of the S-I stage of the C-1 vehicle to include a greater propellant capacity and the addition of fins. Special emphasis was placed upon the safety requirements for manned missions: in performance, the rocket had to be absolutely reliable. And, while the new changes still allowed the possible use of a third (S-V) stage for special missions, the immediate need for a third stage was eliminated.

The test sequence for the vehicles was also evolving. The design philosophy of an evolutionary development of the Saturn rockets carried over into the test flights. Each flight was designed to gain new knowledge for the overall design problems of the rocket.

The first four vehicles scheduled for flight were designed specifically to develop the first stage only. The upper stages



President Eisenhower talks with Dr. von Braun at the dedication of the George C. Marshall Space Flight Center.

of these vehicles were inert or dummy stages. Such stages duplicated the overall external characteristics of the later live stages, and each had the same approximate center of gravity and weight as its live counterpart.

Some of the upper stages to be used with these first four vehicles were already in the process of being manufactured before it was decided to use the C-1 vehicle in the Apollo program; therefore, the dummy stages duplicated the three-stage C-1 configuration--the S-IV and S-V stages atop the S-I stage.

The first four vehicles were designated as the Block I phase. In addition to the three-stage configuration,

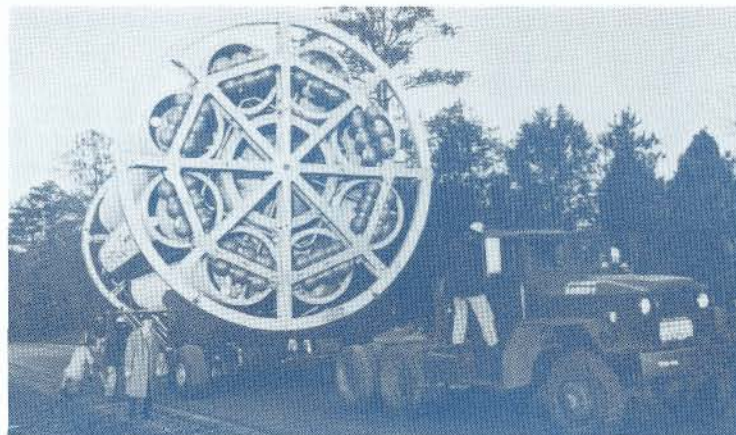

The completed and tested S-I stage is transported to the river and its barge for shipment to the Cape.

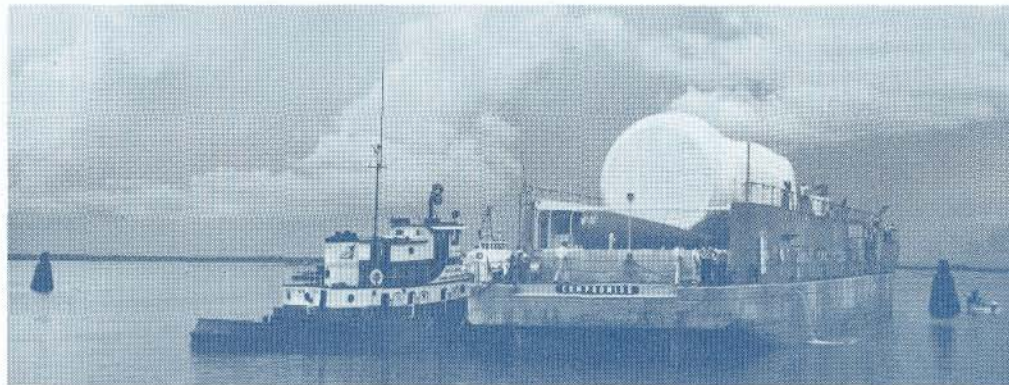

The Saturn SA-1 vehicle components aboard the barge Compromise during the trip to the Cape.

Block I vehicles were easy to distinguish from the later vehicles in that they had no fins. There were other differences between the earlier and later vehicles, but these two basic ones were instantly evident to the casual observer.

The remaining six vehicles in the ten-vehicle developmental series of the C-1 vehicle were designated as the Block II phase. All Block II vehicles would have live second stages, and all but one had payloads in Apollo configurations. These payloads, called boilerplate configurations, would duplicate the mass, center of gravity, and external characteristics of the operational Apollo spacecraft.

Pictured here are NASA management officials for Apollo/Saturn. From top left: James E. Webb, NASA Administrator; Dr. Robert C. Seamans, Jr., Associate Administrator; Dr. George E. Mueller, Associate Administrator for Manned Space Flight; Dr. Wernher von Braun, Director, Marshall Space Flight Center; Dr. Kurt H. Debus, Director, Kennedy Space Center; Dr. Robert R. Gilruth, Director, Manned Spacecraft Center.

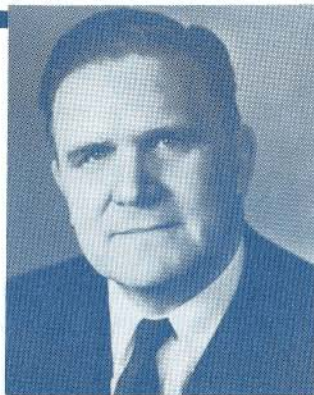

The Saturn program was not to be limited to what was then known as the C-1 vehicle. As the rocket was being developed for the Apollo program, the need was seen for additional, more powerful Saturn vehicles. However, the results of the studies that led to later vehicles are not properly a part of this summary of the Saturn I vehicle, and will be mentioned only in those matters relating to the mission of the Saturn I rocket. It is interesting to note, however, that the expanded Saturn program adheres rigidly to the evolutionary concept that was an intrinsic element of the Saturn I program.

By the time the first S-I stage began its long journey from MSFC to what was then known as Cape Canaveral (Cape Kennedy), a second S-I stage had already undergone a successful static firing test, lasting for 124 seconds, and construction had already begun on a third S-I stage. The stages for the first Saturn had to be transported to the Cape by barge, as they were too large for the normal highway transportation used for earlier rockets.

While the first Saturn was being readied for launch, a conference was held at New Orleans to secure bids for the industrial production of S-I stages. Design had reached the point at which industrial production of the vehicle could be considered.

Then, on October 27, 1961, slightly over four years from the beginning of the Space Age, the first Saturn rocket was launched. The vehicle, weighing 460 tons at liftoff, rose to a height of 85 miles during its journey. It impacted 214 miles downrange, and close to its predicted impact point. The launch was considered to be almost flawless, the only delays being two weather holds during the countdown.

When launched, the first Saturn rocket was the most powerful rocket known in the world. It proved the principle of building new systems with off-the-shelf hardware, and demonstrated the validity of the clustered-engine concept. For the space program, these accomplishments were secondary to the fact that it performed as predicted in an actual shot: the Saturn rocket was in business as a flight vehicle.

The Saturn I program was due for changes as it continued to evolve. Much of the initial planning had already changed, but the program had established itself as workable. In November 1961, NASA selected Chrysler Corporation as the prime contractor for the first stage, joining Douglas Aircraft Company as the prime contractor for the second stage.

THE SATURN I VEHICLE...

The Saturn I rockets can be divided into two major types or blocks, and the second block can be further subdivided. Primarily, each rocket reflects the evolution of the program, but certain features are basic to all rockets in each block. Before discussing the results of the Saturn program, therefore, an outline of the main features of each block is presented.

Saturn I, Block I - This rocket had only one live stage, the S-I stage. It consisted of eight tanks, each 70 inches in diameter, clustered around a central tank 105 inches in diameter. Four of the external tanks were fuel tanks, for the RP-1 (kerosene) fuel; the other four, which were spaced alternately with the fuel tanks, were liquid oxygen tanks, as was the larger center tank. The fuel tanks were interconnected, as were the liquid oxygen tanks; thus, any engine could obtain propellant from any tank. All fuel tanks and all liquid oxygen tanks drained at the same rates respectively.

The thrust for the stage came from eight H-1 engines, each producing a thrust of 165,000 pounds, for a total thrust of over 1,300,000 pounds. The engines were arranged in a double pattern: four engines, located inboard, were fixed in a square pattern around the stage axis, canted outward slightly, while the remaining four engines were located outboard in a larger square pattern offset 45° from the inner pattern. Unlike the inner engines, each outer engine was gimbaled. That is, each could be swung through an arc, in this case an arc of 14°, in two directions. The capability was termed a "±7° square gimbal pattern." The outboard engines were gimbaled as a means of steering the rocket, by letting the instrumentation of the rocket correct any deviations of the rocket's powered trajectory. Since the Block I rocket had no fins, engine gimbaling was also the only method of guiding and stabilizing the rocket through the lower atmosphere.

The upper stages of the Block I rocket reflected the three-stage configuration of the Saturn I vehicle. The ballast of the dummy upper stages was primarily water. It was determined that water could not survive reentry, thus giving an added safety factor to the tests. Typical height of a Block I vehicle was approximately 163 feet.

Saturn I, Block II - This vehicle had two live stages, and was basically in the two-stage configuration of the Saturn I vehicle (that is, it did not loft any dummy third stages). The first stage was an improved version of the Block I S-I stage. While the tank arrangement and the engine patterns were the same, there were marked changes between the Block I and II versions. The Block II S-I stage had eight fins added for greater aerodynamic stability in the lower atmosphere. Four of these fins were larger than the other four, and the two sets were arranged alternately; they were known as the large fins and the stub fins respectively. The engines were still arranged in the two-square pattern with both squares centered on

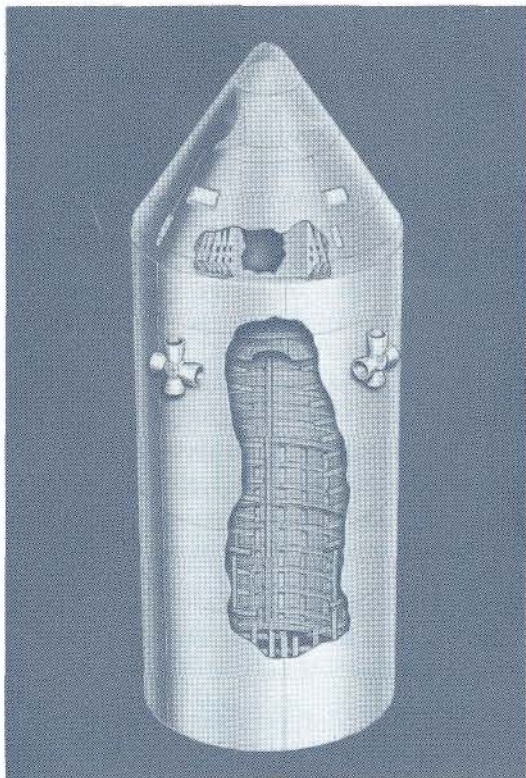

The inert, or Boilerplate, configuration used on the later Saturn I vehicles. This dummy construction faithfully duplicated the mass and the external characteristics of the Apollo spacecraft.

the vehicle axis, but the outboard engines of the Block II phase had a $\pm 8^\circ$ gimbal pattern. All Block II H-1 engines had a thrust of 188,000 pounds each, for a combined thrust of over 1,500,000 pounds.

The Block II second stage (S-IV) used liquid hydrogen and liquid oxygen as its propellants. Unlike other propellant tank systems, the liquid hydrogen and liquid oxygen tanks shared a common bulkhead made of two sheets of aluminum bonded to a fiberglass honeycomb core. The stage had six RL-10 hydrogen-oxygen engines arranged in a circle. Each of these engines produced a thrust of 15,000 pounds for a total combined thrust of 90,000 pounds. Each engine was gimbaled for a $\pm 4^\circ$ square.

As a two-stage vehicle, the Saturn I had full orbital capability for a variety of payloads. A Jupiter nose cone, a boilerplate (dummy) Apollo spacecraft, and meteoroid detection satellites were orbited as payloads by this two-stage configuration.

The later Block II vehicles differed from the earlier vehicles by having an improved Instrument Unit. The Instrument Unit, a joint project of MSFC, the Bendix Corp., and IBM, was the device that acted as the brain of the rocket. Since the later Instrument Units were lighter and physically smaller than the earlier version, the later Block II vehicles were a few feet shorter and somewhat lighter than the earlier Block II vehicles, with improvement in the characteristics of the vehicles.

The height of the vehicle varied with the mission; a typical height for a later Block II vehicle was approximately 188 feet.

THE FLIGHTS AND THE MISSIONS...



Each Saturn I vehicle had a mission that helped in the evolution of future space rockets. Even in the final launch of the series, on what was an operational vehicle, improvements and performance evaluations of the instrumentation and guidance systems were being undertaken. The evolutionary trend of the rocket design is reflected in the achievements of the individual flights.

Saturn SA-1 in the process of being launched. It was the most powerful rocket known at the time of its flight.

SA-1

With SA-1, the Saturn clustered-engine concept was demonstrated to be valid. The eight engines of this rocket produced a thrust of 1,300,000 pounds; this was true of all Block I vehicles. The dummy upper stages of this rocket were not intended to be separated after cutoff of the live stage.

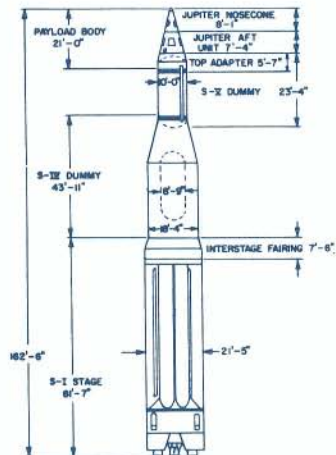

SA-1 being readied before launch.

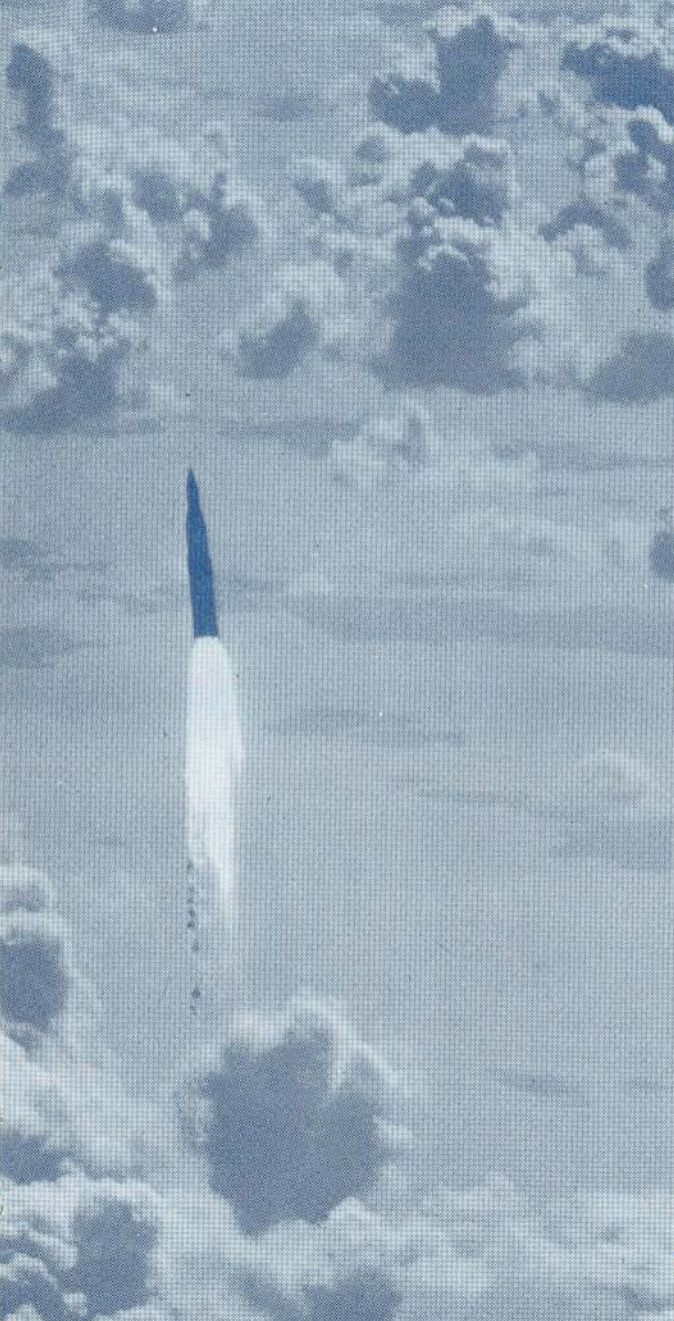

MISSION HIGHLIGHTS

- ✓ ● LAUNCHED WITH NO TECHNICAL HOLDS
- MAXIMUM ALTITUDE -- 85 NAUTICAL MILES
- MAXIMUM RANGE -- 214 NAUTICAL MILES
- AIRFRAME STRUCTURAL RIGIDITY DEMONSTRATED
- ✓ ● CONTROL PERFORMANCE AND RELIABILITY DEMONSTRATED
- ✓ ● COMPATIBILITY TO GROUND SUPPORT EQUIPMENT DEMONSTRATED

OCTOBER 27,1961

PROJECT HIGHWATER

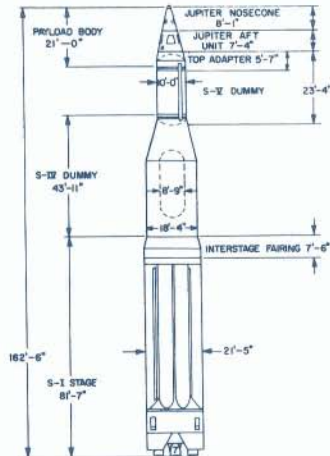

The SA-2 continued the experiments of the SA-1 flight. In addition, a special experiment with widespread scientific interest, "Project Highwater," authorized by the NASA Office of Space Sciences, was conducted. The experiment released nearly 30,000 gallons of ballast water in the upper atmosphere. Release of this vast quantity of water in a near-space environment marked the first purely scientific large-scale experiment concerned with space environments that was ever conducted. The water was released at an altitude of 65 miles, where, within only 5 seconds, it expanded into a massive ice cloud 4.6 miles in diameter. This cloud continued to climb to a height of 90 miles.

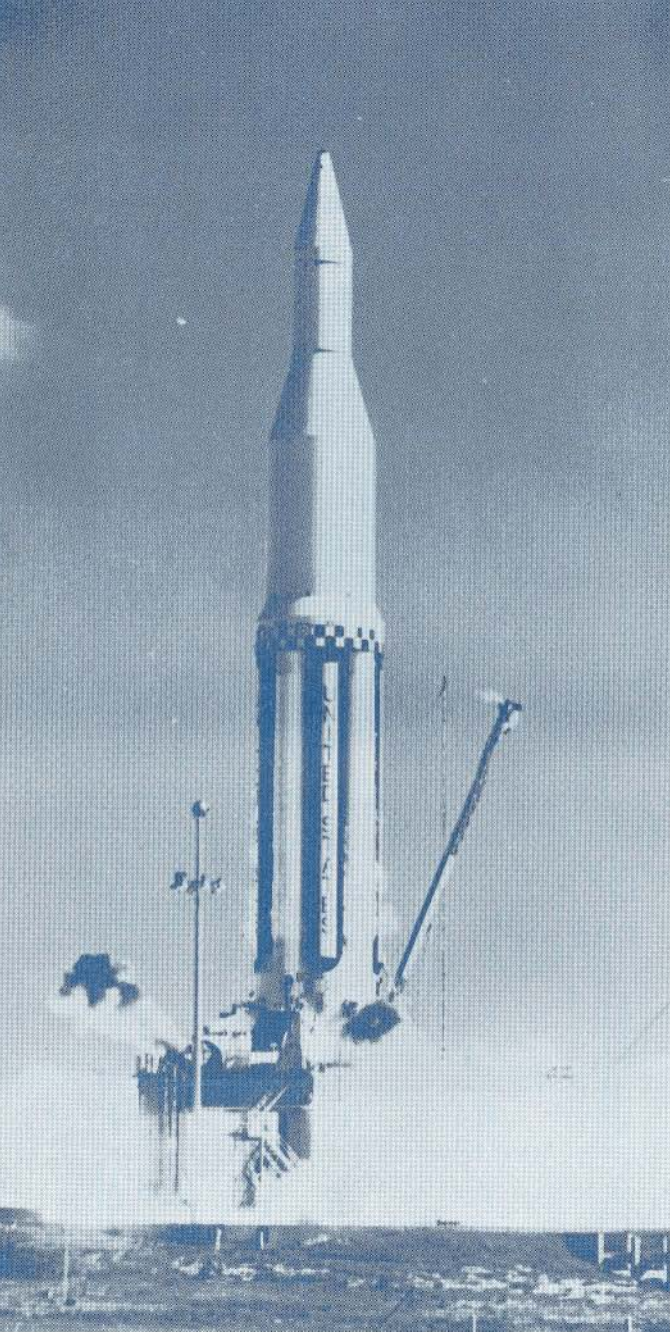

MISSION HIGHLIGHTS

- LAUNCHED WITH NO VEHICLE TECHNICAL HOLDS
- MAXIMUM ALTITUDE -- 65 NAUTICAL MILES
- MAXIMUM RANGE -- 50 NAUTICAL MILES
- AIRFRAME STRUCTURAL INTEGRITY VERIFIED
- CONTROL PERFORMANCE AND RELIABILITY VERIFIED
- COMPATABILITY TO GROUND SUPPORT EQUIPMENT VERIFIED
- PROJECT HIGHWATER EXPERIMENT COMPLETED SUCCESSFULLY

APRIL 25, 1962

The SA-3 carried on the experiments of the SA-2 flight, including the Highwater project. In addition, one of the first experiments necessary for the development of the Block II vehicle phase was conducted: the firing of four solid-fuel retro-rockets identical to those to be used in the Block II phase stage separation sequence, although the upper stages were not intended to separate in the Block I rockets. Other experiments related to the Block II vehicles were performed successfully, as was an experiment related to the Centaur program.

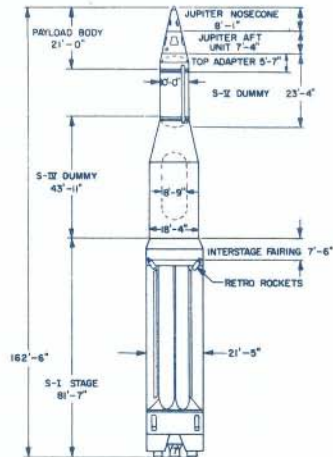

Typical scene at the Launch Control Center of Launch Complex 34 during a Saturn launch.

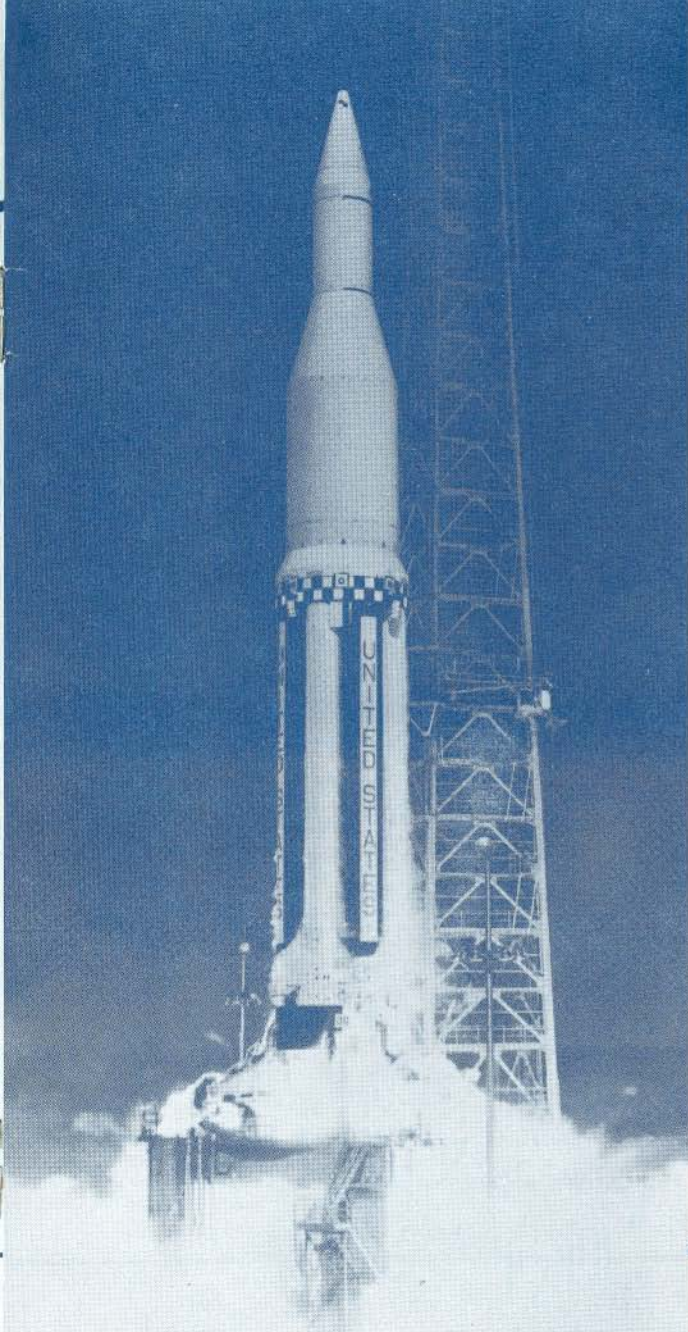

MISSION HIGHLIGHTS

- MAXIMUM ALTITUDE -- 104 NAUTICAL MILES
- MAXIMUM RANGE -- 131 NAUTICAL MILES
- AIRFRAME STRUCTURAL INTEGRITY VERIFIED
- CONTROL PERFORMANCE AND RELIABILITY VERIFIED
- COMPATIBILITY TO GROUND SUPPORT EQUIPMENT VERIFIED
- TEST OF BLOCK II SWING ARMS
- TEST OF PROTOTYPE HORIZON SENSOR
- FLIGHT TEST OF PASSENGER STABILIZED PLATFORM
- TEST OF PULSE CODE MODULATION (PCM) AND UHF TELEMETRY
- TEST OF BLOCK II HEAT SHIELD PANEL
- TEST FIRING OF RETROROCKETS (NO SEPARATION)
- SIMULATION OF BLOCK II ULLAGE VOLUMES
- ACHIEVEMENT OF SIGNIFICANT INCREASE IN PROPELLANT UTILIZATION THROUGH NEW CUTOFF METHOD
- CENTAUR ROCKET PRESSURE DISTRIBUTION STUDY
- PROJECT HIGHWATER EXPERIMENT SUCCESSFULLY COMPLETED

NOVEMBER 16, 1962

The SA-4 was the final vehicle of the Block I phase. Besides carrying on the experiments of the first three Saturns, the SA-4 carried considerable amounts of equipment to be used in the Block II phase. The external characteristics of the SA-4 vehicle reflected more closely the Block II design than any previous vehicle. In addition to the retro-rockets added to the design on SA-3, dummy camera pods were attached to the S-I stage to simulate the actual camera pods that would be used on some of the Block II vehicles. Also, and far more obvious, dummy aerodynamic protuberances were added to the inert S-IV stage to simulate the ullage rockets that would be used on the live rocket stage.

A special feature of the clustered engine concept is that, if an engine fails past a critical point on a flight path, it may be possible to carry out the mission by utilizing the remaining operating engines. If a vehicle is specifically designed to do this, as was the Saturn I, the vehicle is said to have an "engine-out capability."

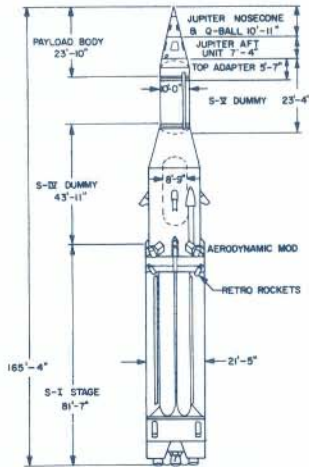

Since the Saturn engine-out capability had not been demonstrated, it was decided to program a premature cutoff of one engine as an experiment on the SA-4 flight to demonstrate the validity of the design calculations. One of the engines was cut off deliberately after 100 seconds of flight time, and the remaining portion of the flight was made using only seven engines. The flight performed as calculated, and the engine-out principle was proven to be a valid engineering approach.

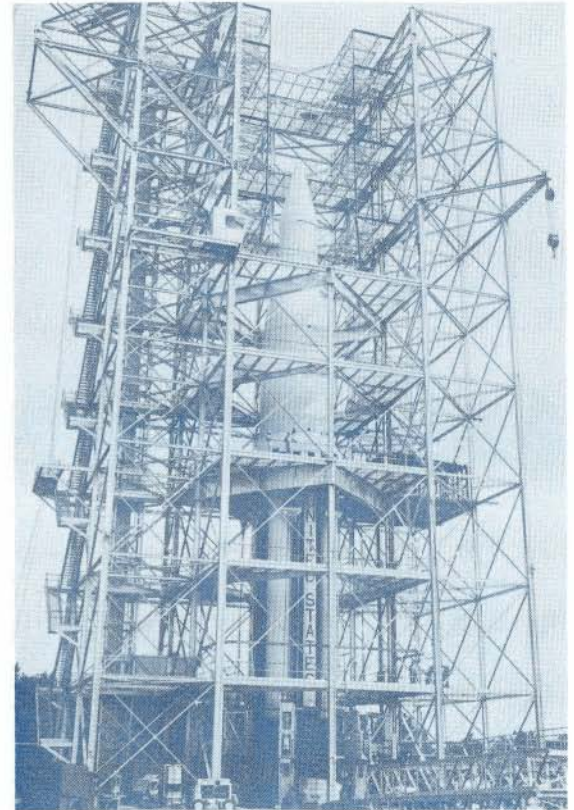

Full-scale model mockup of Block I vehicle undergoes vibration analysis in this dynamic test tower at MSFC to insure perfect engineering in the flight models.

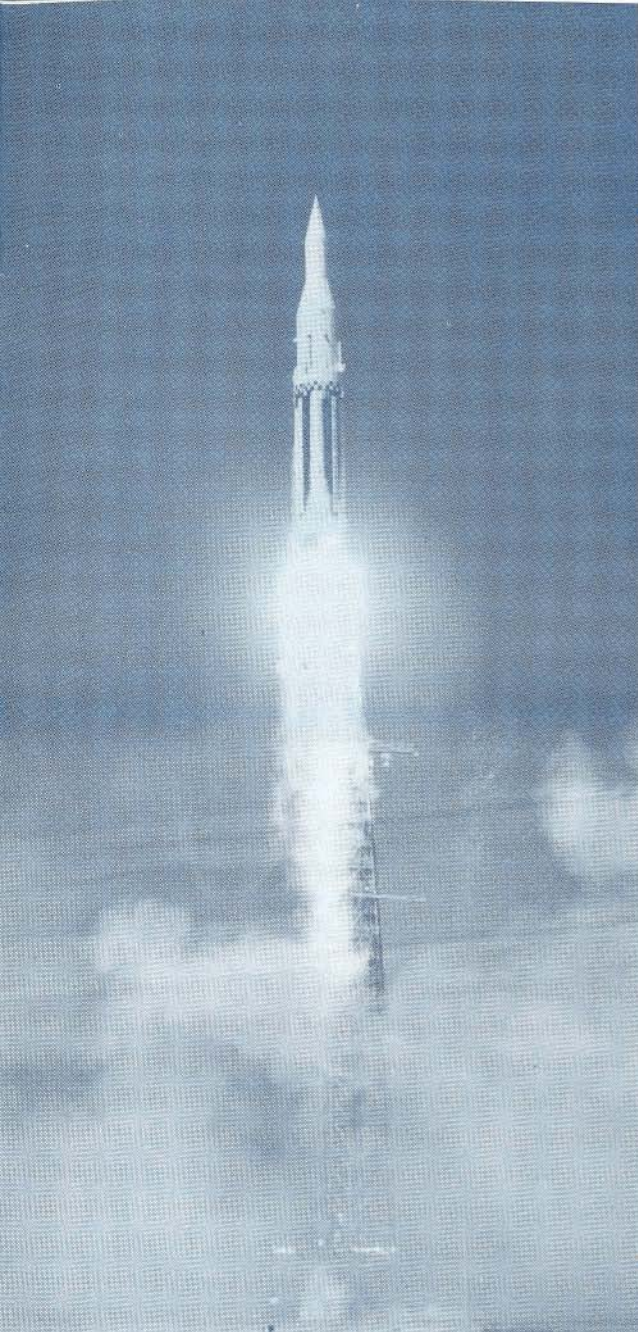

MISSION HIGHLIGHTS

- MAXIMUM ALTITUDE -- 81 NAUTICAL MILES
- MAXIMUM RANGE -- 219 NAUTICAL MILES
- AIRFRAME STRUCTURAL INTEGRITY WAS VERIFIED FOR USE OF SOME BLOCK II AERODYNAMIC PROTRUSIONS
- CONTROL PERFORMANCE AND RELIABILITY VERIFIED
- TEST OF PROTOTYPE HORIZON SENSOR
- THERMAL FLIGHT TEST OF SELECTED SENSING DEVICES
- TEST OF BLOCK II ANTENNA PANELS
- USE OF ONBOARD PLAYBACK RECORDER FOR DATA GATHERING
- PASSENGER TEST OF Q-BALL ANGLE-OF-ATTACK DEVICE
- PASSENGER TEST OF RADAR ALTIMETER
- PASSENGER TEST OF MISTRAM DEVICE
- SUCCESSFUL ENGINE-OUT TEST
- VERIFICATION OF PROPELLANT UTILIZATION IMPROVEMENT BY CUTOFF METHOD
- TEST OF PCM AND UHF TELEMETRY
- TEST OF BLOCK II HEAT SHIELD PANELS CONTINUED
- RETROROCKET FIRING (NO SEPARATION)
- FLIGHT TEST OF PASSENGER STABILIZED PLATFORM

MARCH 28, 1963

SA-5

The SA-5 was the first of the Block II vehicles. While a part of the orderly evolution of the Saturn I design, it was a definite milestone. Although it still retained a Jupiter nose cone and had a payload compartment only slightly different from the dummy S-V stages of the Block I vehicles, it had a live second stage that gave the Saturn I orbital capabilities for the first time.

The S-IV stage itself was a major developmental milestone, being powered by a propellant combination of liquid hydrogen and liquid oxygen. Liquid hydrogen in combination with an oxidizer produces considerably more thrust than the more conventional fuels, but until recently the technology of liquid hydrogen rocketry was new. And in performance, the clustered engine concept again proved valid.

Cameras recovered from the SA-5 flight recorded the S-IV stage separation and the ignition of the second stage engines.

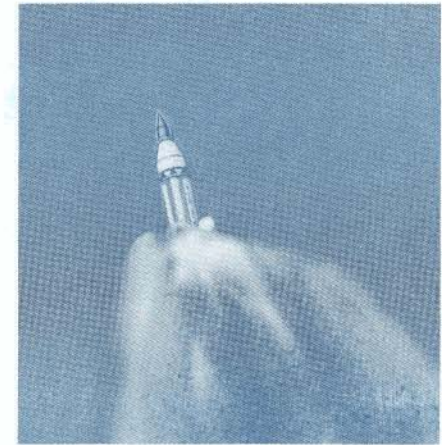

SA-5 in flight, shortly before first stage cutoff.

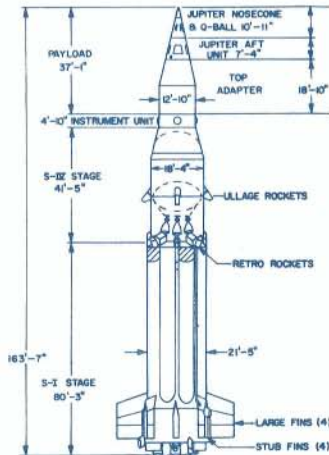

There were many firsts on the SA-5 flight. A new Instrument Unit, prototype of the Instrument Units to be flown on later vehicles, was used. The Instrument Unit, located immediately above the S-IV stage, acted as the overall brain of the vehicle. The path of the powered portion of the flight was directed from the Instrument Unit, and many sensing and evaluating instruments were controlled through this central point.

Beginning with the SA-5, the S-I stage used the uprated H-1 engines, each of which had a thrust of 188,000 pounds. Thus, with SA-5, the first rocket with a first-stage thrust of 1,500,000 pounds was launched.

The flight was an unqualified success, injecting the largest payload then recorded into an earth orbit.

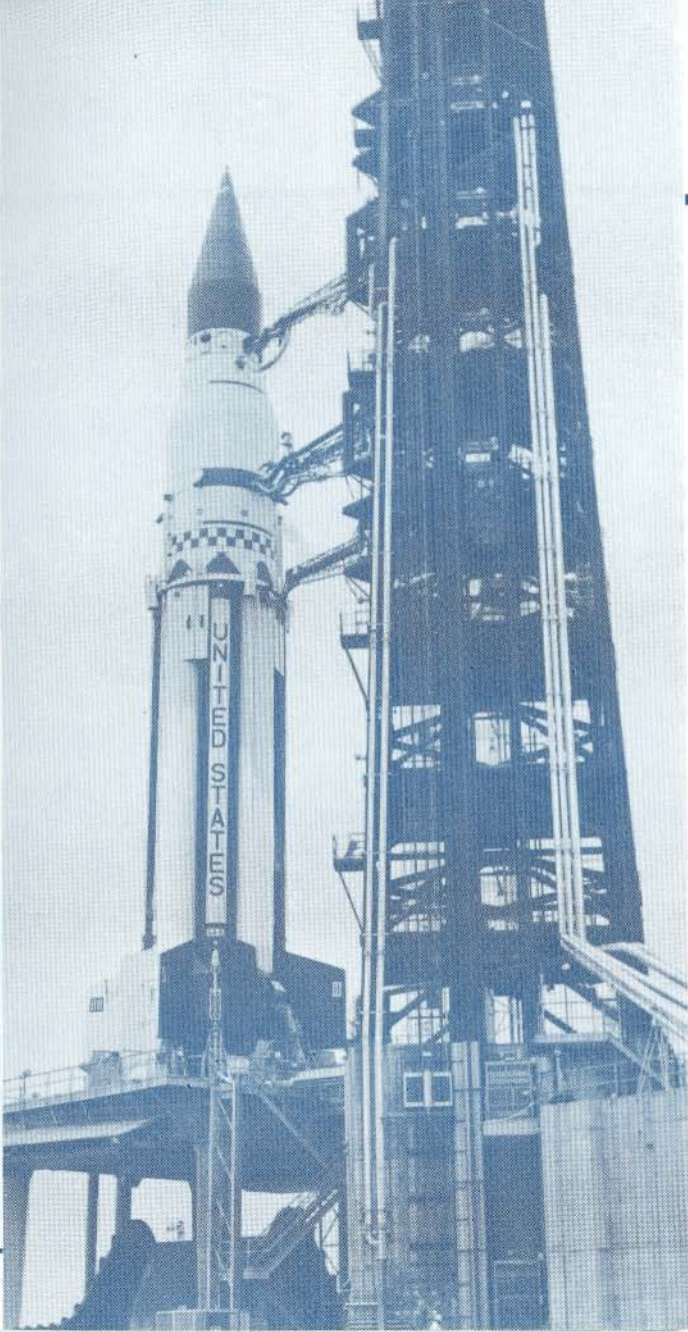

MISSION HIGHLIGHTS

- FIRST LAUNCH OF BLOCK II VEHICLE
- FIRST FLIGHT TEST OF S-IV STAGE
- FIRST FLIGHT TEST OF INSTRUMENT UNIT
- FLIGHT CONTROL UTILIZATION OF S-I STAGE FINS DEMONSTRATED
- SUCCESSFUL PASSENGER FLIGHT OF ST-124 GUIDANCE SYSTEM
- ✓ ● SUCCESSFUL STAGE SEPARATION
- ✓ ● FIRST ORBITAL SATURN VEHICLE
- FIRST SATURN VEHICLE USING UPDATED H-1 ENGINES
- SUCCESSFUL RECOVERY OF MOTION PICTURE CAMERA CAPSULES FROM S-I STAGE
- INJECTION OF 38,000-POUND SATELLITE INTO ORBIT

JANUARY 29, 1964

SA-6

SA-6 was the second of the developmental Block II vehicles, and the first to loft a dummy Apollo capsule. While continuing the developmental experimentation of the previous missions, SA-6 was the next step in the development of the rocket for its basic purpose--the development of a two-stage launch vehicle that would be used in support of the Apollo manned program.

The mission objectives were extensions of those of the SA-5 vehicle. In addition to the basic mission objectives of SA-5, the sixth Saturn vehicle was to demonstrate capabilities, such as the in-flight environmental parameters of the spacecraft and the normal jettisoning of the Launch Escape System tower, that would assist in designing the manned Apollo vehicles.

Like the SA-5 vehicle, the SA-6 had motion picture cameras on board that recorded the propellant consumption of the S-I stage and the separation of the S-I and S-IV stages. These cameras were attached to the vehicle in special recoverable camera pods. After the separation of the stages, the camera pods were ejected from the S-I stage and, with it, continued in a ballistic trajectory. Unlike the stage, however, the camera pods were equipped with special recovery parachute devices that enabled the camera pods to land relatively intact in the ocean downrange where they were recovered by ship.

The SA-6 vehicle demonstrated the validity of the clustered engine concept and the value of the engineering planning of an "engine-out" capability. One of the engines aboard the vehicle cut off prematurely. Although this was not part of the programmed flight, the performance of the remaining seven engines ensured the successful completion of the mission.

The SA-6 injected the spent S-IV stage, the Instrument Unit, and the Apollo Spacecraft assembly into orbit, having a total weight substantially in excess of 18 tons.

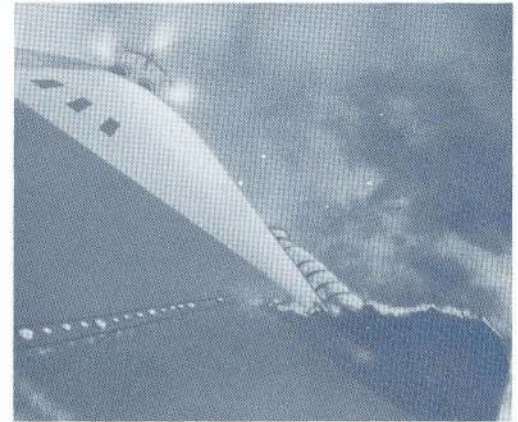
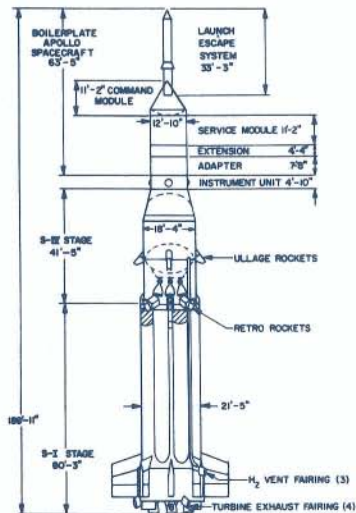

The S-IV stage blasts away from the S-I stage as separation is completed.

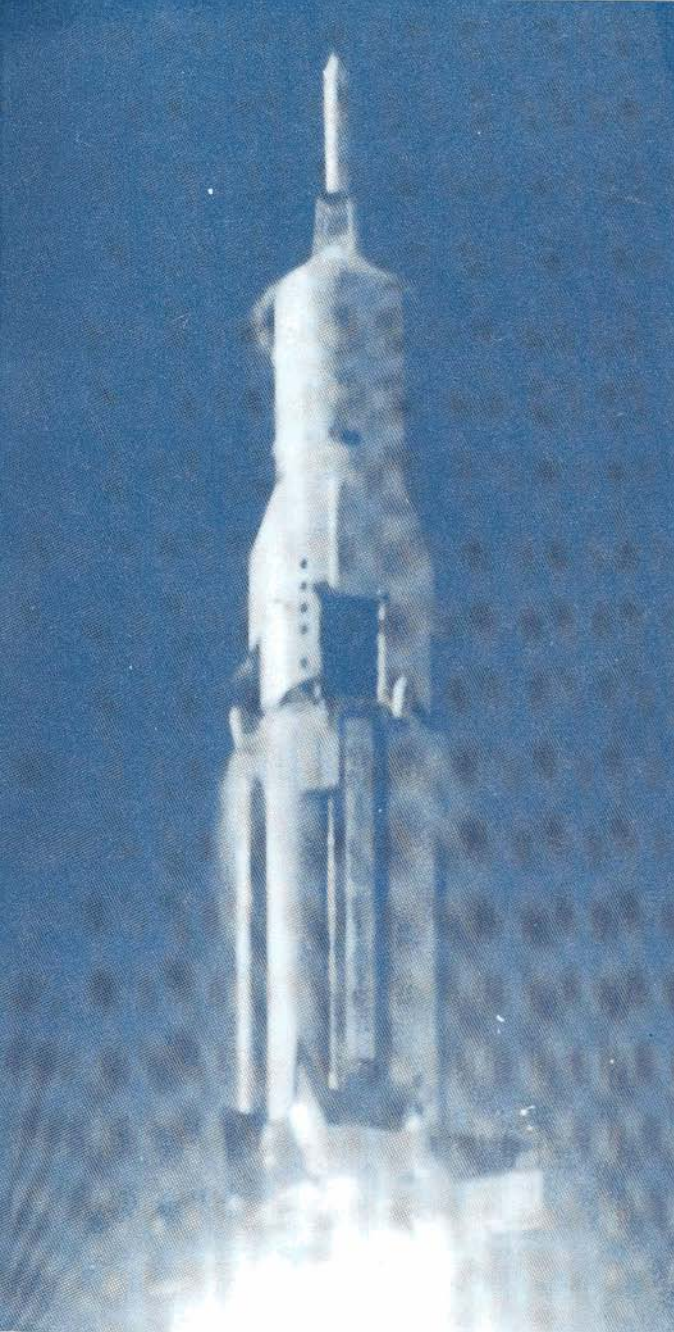

MISSION HIGHLIGHTS

- DEMONSTRATION OF PHYSICAL COMPATIBILITY OF THE LAUNCH VEHICLE AND THE FIRST APOLLO BOILERPLATE
- PARTIAL ACTIVE TEST OF THE ST-124 SYSTEM
- FIRST TEST OF GUIDANCE VELOCITY AT CUTOFF
- SUCCESSFUL MISSION WITH PLANNED LARGE ANGLE OF ATTACK
- RECOVERY OF MOTION PICTURE CAPSULES FROM S-I STAGE
- DEMONSTRATION OF LAUNCH ESCAPE SYSTEM UNDER FLIGHT CONDITIONS
- ENGINE-OUT CAPABILITY SHOWN IN ACTUAL ENGINE CASUALTY
- INJECTION OF 37,000-POUND SATELLITE INTO ORBIT

MAY 28, 1964

The SA-7 was the first of the Block II vehicles that was considered operational. The unparalleled success of the Saturn I program allowed the research and development phase of the Saturn I program to be completed earlier than had been expected.

An important mission of SA-7 was to demonstrate a different method of jettisoning the Launch Escape System tower from the one used aboard SA-6. It is necessary to jettison these towers once the rocket reaches a point where they would no longer be useful, and the successful demonstration of two different methods of this operation shows flexibility that can prove useful for eventual design situations.

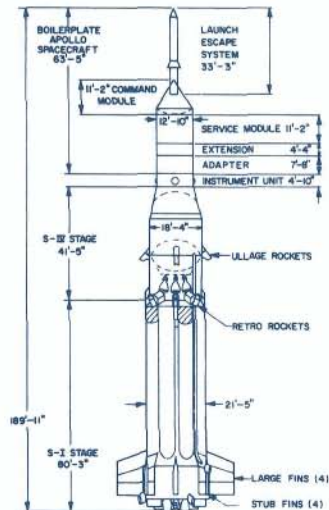

Many of the remaining missions were similar to those of SA-6, with some being extensions of the missions of the earlier vehicle. The movie camera setup was the same, although the results were a little different than had been anticipated, due to the intervention of a hurricane. When the camera pods had been ejected, they re-entered flawlessly, but landed in a region of the sea close to Hurricane Gladys, and the hurricane closed in before the capsules could be recovered. Though given up for lost, two of the capsules washed ashore after seven weeks, none the worse for wear, save for the acquisition of a few barnacles.

The overall mission of SA-7, however, was the same--the injection into orbit of a dummy Apollo spacecraft, an S-IV stage, and the Instrument Unit--a total weight of 19 1/2 tons.



Two SA-7 camera pods, which were recovered after seven weeks--the delay caused by Hurricane Gladys.

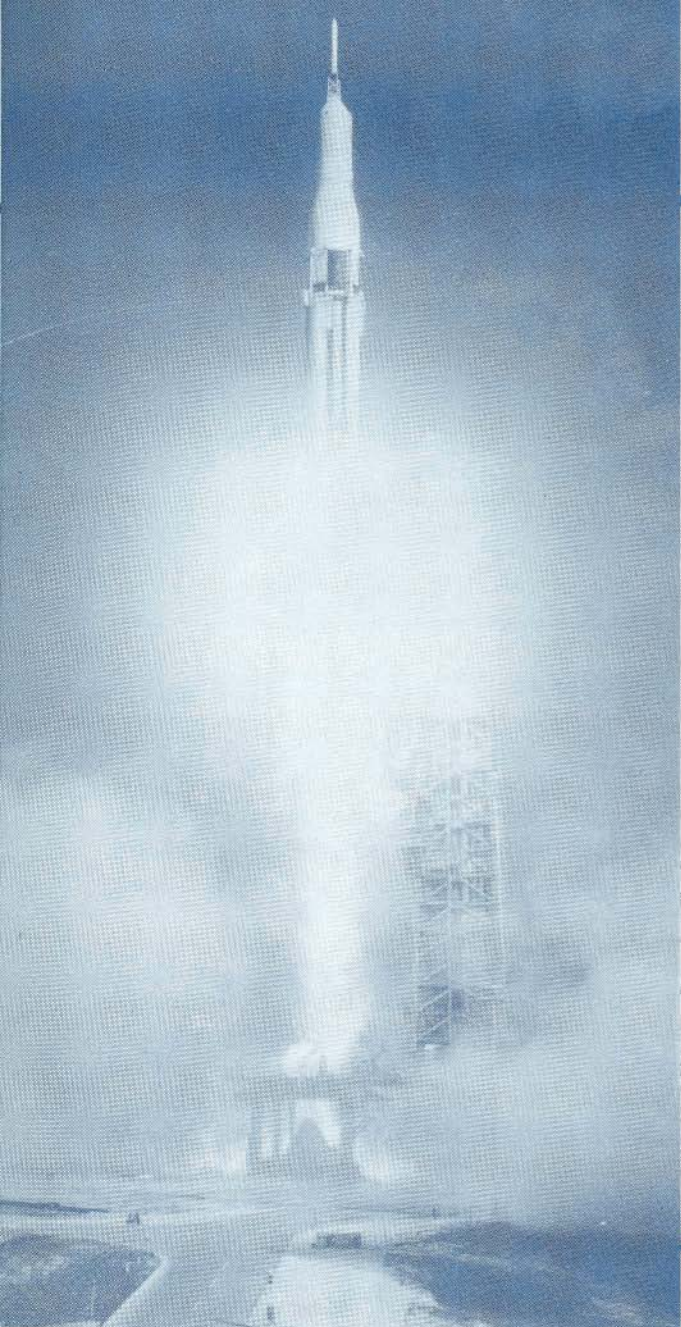

MISSION HIGHLIGHTS

- FIRST COMPLETE FLIGHT TEST OF ST-124 SYSTEM USING CLOSED LOOP
- FIRST FLIGHT DEMONSTRATION OF THE SPACECRAFT ALTERNATE L.E.S. TOWER JETTISON MODE
- FIRST TEST OF S-IV STAGE NON-PROPULSIVE VENTING SYSTEM
- PASSENGER TEST OF S-I AREA FIRE DETECTION SYSTEM
- FIRST TEST NOT USING S-IV STAGE LOX BACKUP PRESSURIZATION SYSTEM
- THIRD FLIGHT TEST OF INSTRUMENT UNIT
- FIRST FLIGHT OF ACTIVE ASC TIME TILT POLYNOMIAL SYSTEM FOR THE S-I STAGE
- THIRD ORBITAL FLIGHT; SECOND ORBITAL FLIGHT OF EXPENDED S-IV STAGE, INSTRUMENT UNIT, AND APOLLO BOILERPLATE, HAVING AN APPROXIMATE WEIGHT OF 39,100 POUNDS

SEPTEMBER 18, 1964

The vehicle designated SA-9 was the next vehicle launched after SA-7. The reason for the mismatch between vehicle numbers and flights is that two of the Saturn I rockets were scheduled to have first stages that were manufactured by private industry, the Chrysler Corporation Space Division; these rockets were designated SA-8 and SA-10. Although the last rocket with an MSFC-manufactured first stage was to be launched before the first one using Chrysler-built stages, it was numbered SA-9, since it was launched after SA-7 and the SA-8 designation had already been assigned.

This was the first of the later Block II vehicles. One of the major differences between the earlier and later Block II vehicles was in the design of the Instrument Unit. The earlier Instrument Unit was divided into "conditioned" tubular sections. Each section was pressurized and the components were enclosed within the sections, surrounded by an inert gas for environmental control. The later Instrument Unit was not pressurized; the components had no external temperature control. The components were mounted to the wall of the IU, which was merely a wall cylinder, and some of them had individual prelaunch heating elements incorporated into their design.

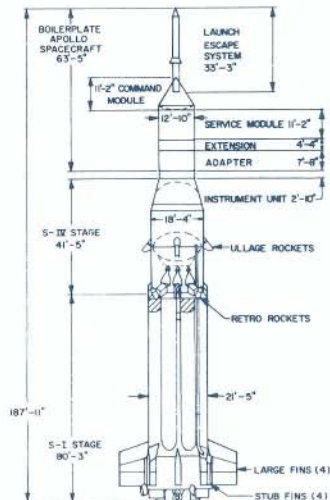

An artist's concept of the Pegasus satellite, with the wings fully deployed.

The SA-9 launched the Meteoroid Technology Satellite (MTS), sponsored by the NASA office of Advanced Research and Technology, and built by the Fairchild-Hiller Corporation. This satellite was nicknamed "Pegasus" after the winged horse of Greek mythology because it had two vast "wings," which consisted of panels to detect meteoroid impacts. Impact information was transmitted to the ground. In addition to the fundamental scientific value of such data, the information of meteoroid density is of extreme importance for our manned space program, since it gives us an idea of the penetration hazards of meteoroids to be encountered in an earth orbit environment.

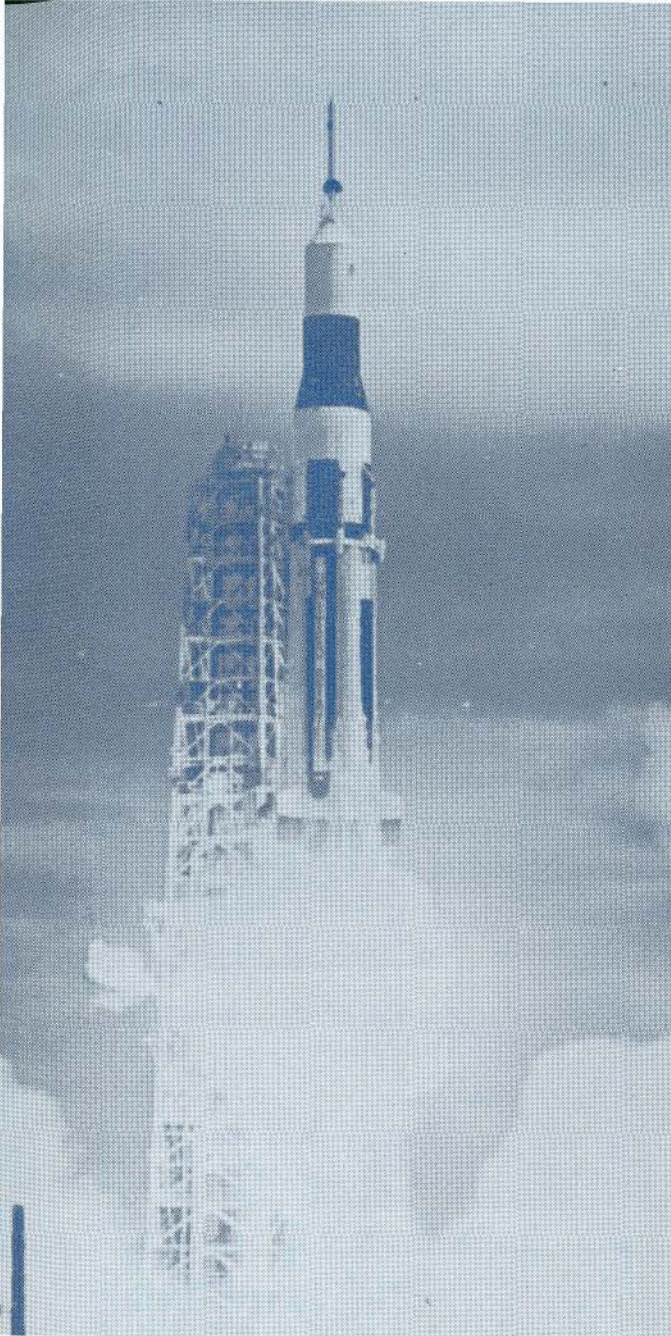

MISSION HIGHLIGHTS

- FIRST SATURN ROCKET WITH AN OPERATIONAL PAYLOAD
- PEGASUS SATELLITE DEMONSTRATES FUNCTIONAL OPERATIONS
- EVALUATION OF CLOSED-LOOP GUIDANCE ACCURACY
- FIRST FLIGHT UTILIZATION OF ITERATIVE GUIDANCE SCHEME
- FIRST FLIGHT OF AN IMPROVED, NONPRESSURIZED INSTRUMENT UNIT
- EVALUATION OF A THERMAL CONTROL COATING FOR S-IV STAGE, INSTRUMENT UNIT, AND ADAPTER OF SERVICE MODULE
- DEMONSTRATION OF SEPARATION OF THE BOILERPLATE SERVICE AND COMMAND MODULES FROM THE S-IV STAGE AND INSTRUMENT UNIT
- FIRST LIVE, HIGH-RESOLUTION, FAST-SCAN, TELEVISION BROADCAST ORIGINATING ON AN ORBITING SATELLITE
- ORBITING OF 33,900-POUND PAYLOAD CONSISTING OF SPENT S-IV STAGE, INSTRUMENT UNIT, PEGASUS SATELLITE, AND THE APOLLO COMMAND MODULE

FEBRUARY 16, 1965

SA-8

The SA-8 flight was a milestone in the Saturn program. For the first time, both powered stages of the rocket were manufactured by private industry--the S-I stage by Chrysler Corporation, and the S-IV stage by Douglas Aircraft. As an operational vehicle, the SA-8 carried a Pegasus satellite.

In addition to being the first industry-built Saturn, SA-8 was the first Saturn rocket to be launched at night.

Like SA-9 and SA-10, SA-8 carried an on-board live television system to observe the deployment of the Pegasus wings. Television was used for this purpose of observing the operation as it happened.

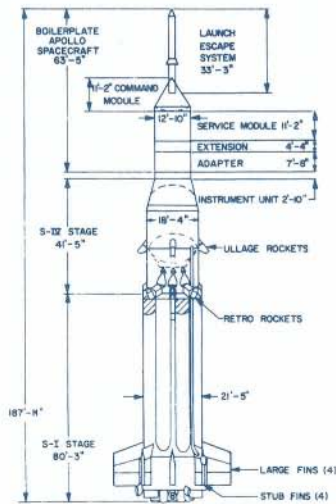

In addition to its basic mission, SA-8 continued the studies of SA-9.

The SA-8 lofted the Pegasus satellite, the spent stage, and the Instrument Unit into an orbit with a minimum altitude (perigee) of 273 nautical miles, and a maximum altitude (apogee) of 420 nautical miles.

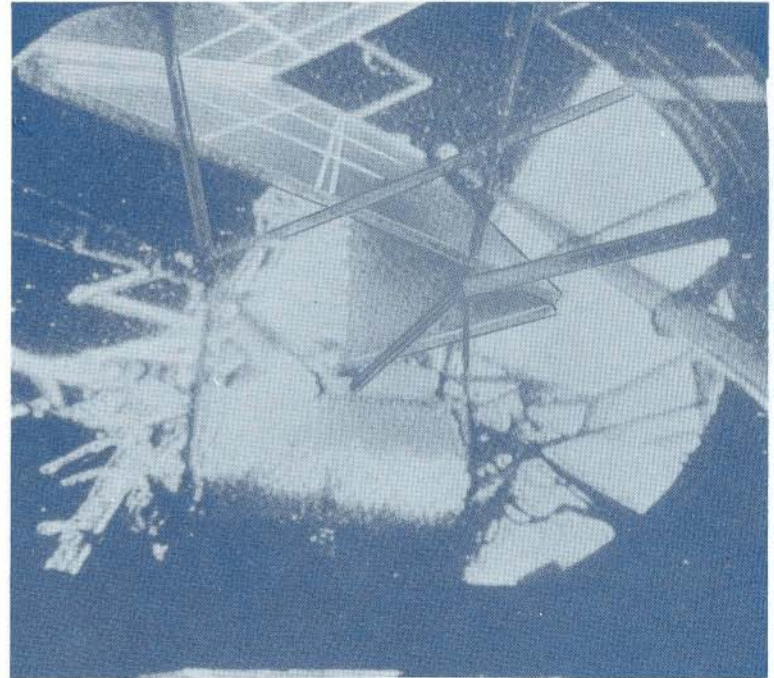

Television from orbit. Onboard cameras transmit the unfolding of the Pegasus satellite wings.



MISSION HIGHLIGHTS

- FIRST SATURN LAUNCHED WITH BOTH STAGES BUILT BY PRIVATE INDUSTRY
- FIRST NIGHT LAUNCH OF A SATURN ROCKET
- EVALUATION OF METEOROID DATA SAMPLING IN NEAR-EARTH ORBIT
- CONTINUATION OF DEMONSTRATION OF FUNCTIONAL OPERATIONS OF THE MECHANICAL, STRUCTURAL, AND ELECTRICAL SUBSYSTEMS OF THE PEGASUS METEOROID SATELLITE
- CONTINUATION OF THE EVALUATION OF THE THERMAL COATING FOR THE EXTERIOR OF THE S-IV STAGE, INSTRUMENT UNIT, AND SERVICE MODULE ADAPTER EXTENSION
- TELEVISION COVERAGE OF THE SEPARATION OF THE BOILERPLATE COMMAND MODULE AND SERVICE MODULE FROM THE PEGASUS SATELLITE AREA
- ORBITING OF 34,100-POUND SATELLITE CONSISTING OF SPENT S-IV STAGE, INSTRUMENT UNIT, PEGASUS SATELLITE, AND THE APOLLO COMMAND MODULE

MAY 25, 1965

SA-10

The SA-10 vehicle marked the close of the most phenomenally successful of the United States' space programs. It also carried a Pegasus satellite into orbit.

Like the two previous vehicles, SA-10 carried a Meteoroid Technology Satellite. Its mission was more complex as it not only measures meteoroid hazards, but also checks out the validity of its own data and those of SA-8 and SA-9. In addition, removable panels were attached to the satellite for possible later recovery by space-maneuvering astronauts.

The recovery of these panels would be of great scientific value, allowing us to examine material that has been exposed to space conditions for prolonged periods of time. Indeed, the information extracted from the recovered panels could contribute materially to our future space station and lunar base design specifications.

The SA-10 lofted its payload into an almost perfectly circular orbit, with a perigee of just under 286 nautical miles, and an apogee of slightly more than 287 nautical miles.

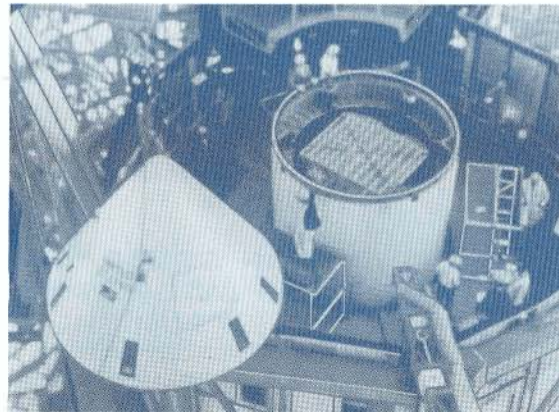
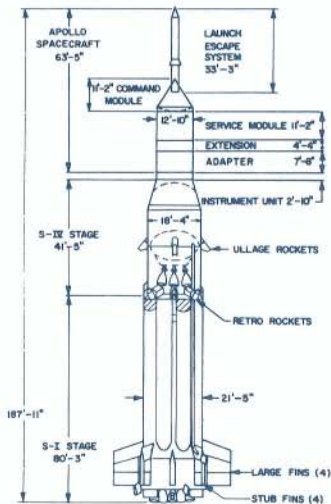

The Apollo capsule is installed on the rocket above the folded Pegasus wings. The capsule was jettisoned before the wings deployed.



Block II Instrument Units. The simplification of systems reduced weight markedly in the later version.

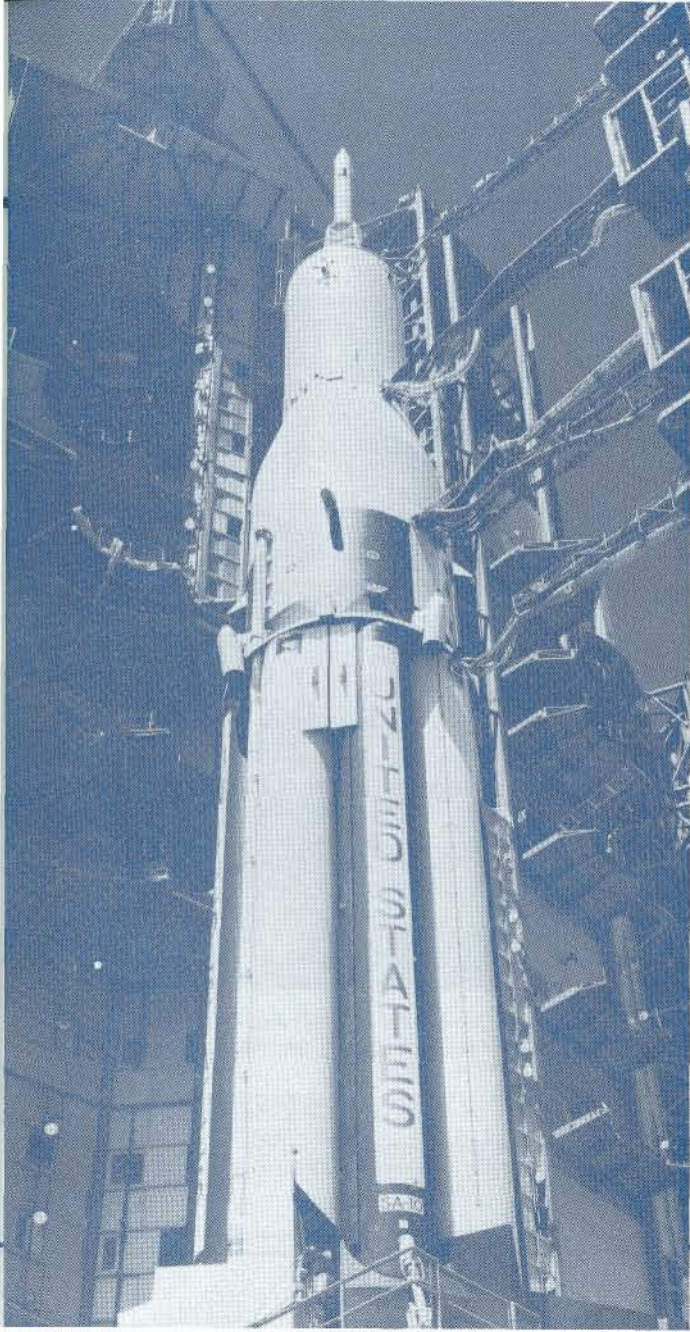

MISSION HIGHLIGHTS

- FINAL LAUNCH OF THE SATURN I SERIES
- DETERMINATION OF METEOROID PENETRATION FOR THREE DIFFERENT THICKNESSES OF ALUMINUM
- MEASUREMENT OF SATELLITE RADIATION ENVIRONMENT AND PANEL TEMPERATURE TO EVALUATE THE VALIDITY OF HIT DATA
- DETERMINATION OF THE POSITION AND ORIENTATION OF THE SATELLITE RELATIVE TO THE TIME OF HIT
- CONTINUED DEMONSTRATION OF THE ITERATIVE GUIDANCE MODE AND EVALUATION OF SYSTEM ACCURACY
- CONTINUATION OF THE EVALUATION OF THE THERMAL COATING FOR THE EXTERIOR OF THE S-IV STAGE, INSTRUMENT UNIT, AND SERVICE MODULE ADAPTER EXTENSION
- ORBITING OF 34,000-POUND PEGASUS SATELLITE, INCLUDING S-IV STAGE AND INSTRUMENT UNIT, INTO NEARLY PERFECT CIRCULAR ORBIT

JULY 30, 1965

THE NASA

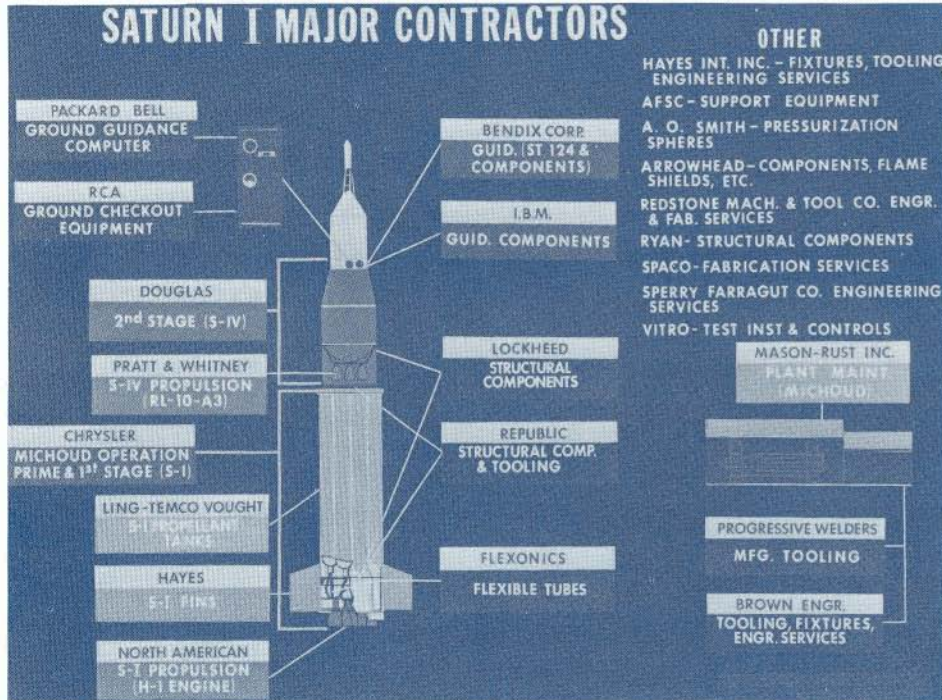

The NASA-Industry Team. These major contractors are but a fraction of the total Saturn I effort. In addition, hundreds of subcontractor companies assisted by manufacturing parts, or by supplying technical support.



The first industry-built S-I stage is presented to NASA by Chrysler President Lynn Townsend in special ceremonies at the Michoud assembly plant.

Success, demonstrated in missions, crowns the efforts of skilled, dedicated people. Reliability was designed and built into the ten Saturn I launch vehicles, and was ensured by the active participation of the personnel of major industrial contractors under the management of MSFC, as well as by the work of NASA personnel.

INDUSTRY TEAM....

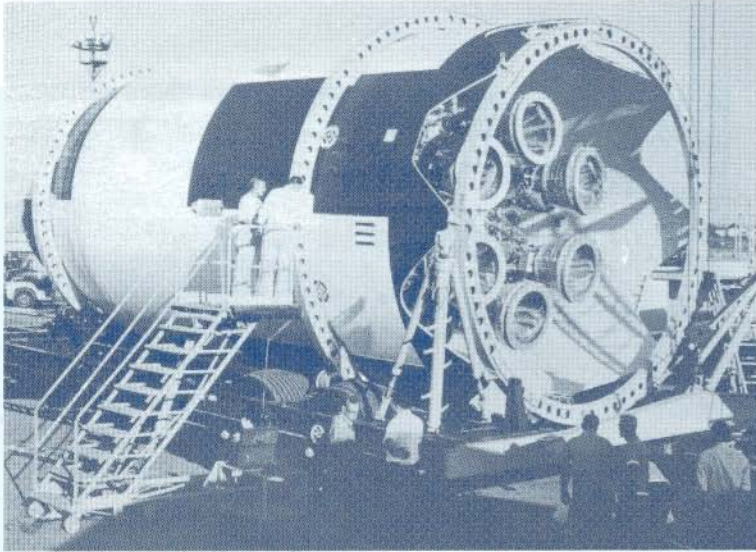

Douglas Aircraft Company engineers check out S-IV stage at their Santa Monica plant.

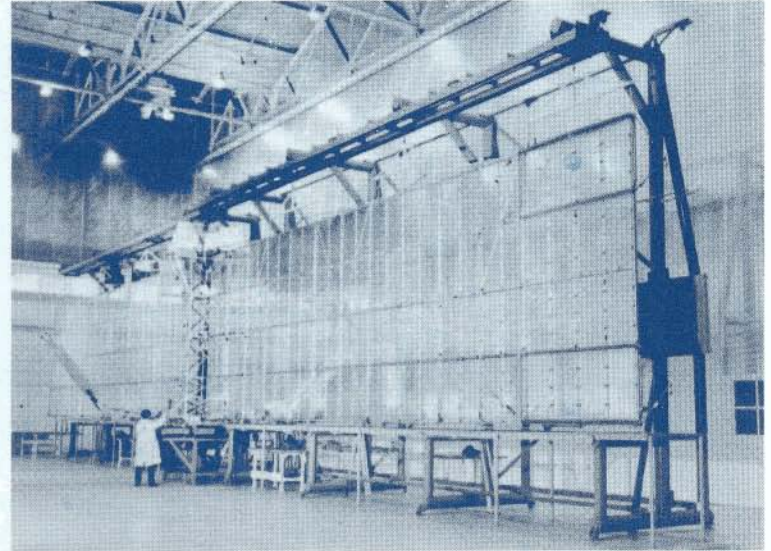

A Fairchild-Hiller engineer checks the deployment of the Pegasus satellite wings.

In this great effort to make America foremost in space, the job is too big for one group or one company or one governmental agency. The overall program management was directed by the Associate Administrator for Manned Space Flight through the NASA Centers for launch vehicle development by Marshall Space Flight Center (MSFC), payload development by Manned Spacecraft Center (MSC) and MSFC, and launch operations by Kennedy Space Center (KSC).

Shown on these pages are examples of the contribution the major contractors made to the Saturn I program. The companies represented are but a sampling of the hundreds of companies that have contributed to the success of the Saturn I, and that are working for the success of all future Saturn vehicles.

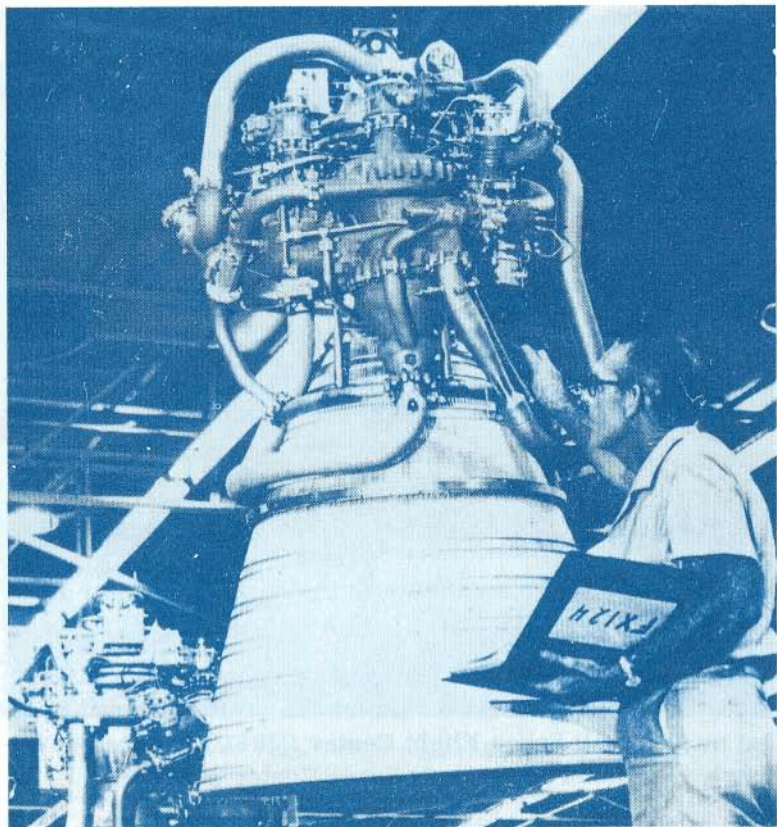

A Pratt & Whitney technician checks out an RL-10 engine at the manufacturing plant. This engine was used in a six-engine cluster on an S-IV stage.

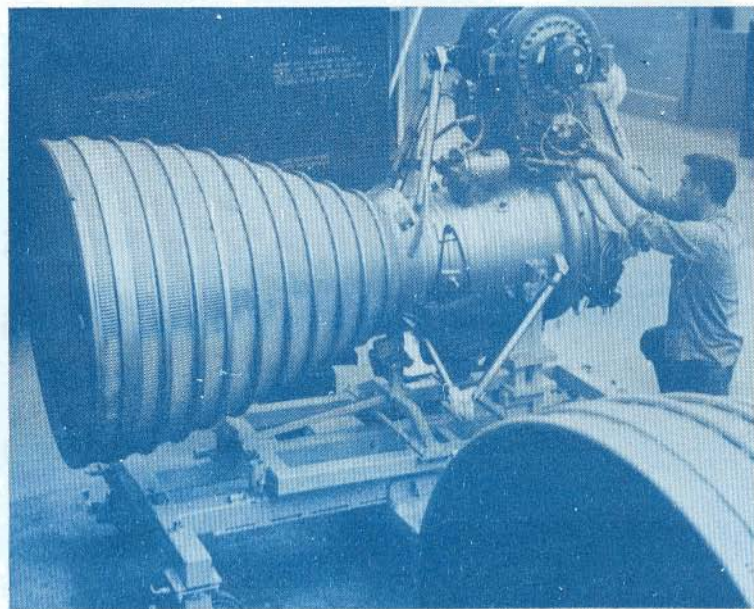

An H-1 engine, manufactured by Rocketdyne, is given a final inspection. An updated version of this engine is scheduled for use on later Saturn vehicles.

INDUSTRY TEAM...



Douglas Aircraft Company engineers check out S-IV stage at their Santa Monica plant.

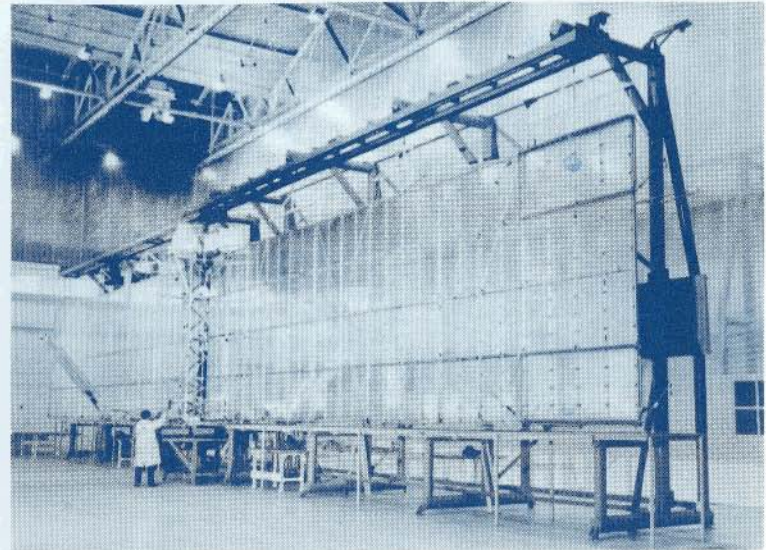

A Fairchild-Hiller engineer checks the deployment of the Pegasus satellite wings.

In this great effort to make America foremost in space, the job is too big for one group or one company or one governmental agency. The overall program management was directed by the Associate Administrator for Manned Space Flight through the NASA Centers for launch vehicle development by Marshall Space Flight Center (MSFC), payload development by Manned Spacecraft Center (MSC) and MSFC, and launch operations by Kennedy Space Center (KSC).

Shown on these pages are examples of the contribution the major contractors made to the Saturn I program. The companies represented are but a sampling of the hundreds of companies that have contributed to the success of the Saturn I, and that are working for the success of all future Saturn vehicles.

THE SUMMING UP...

The Saturn I was not only a successful program, but a very productive one. Having evolved from established design concepts, the rocket was not plagued with some of the failures normally associated with a rocket development program. We have seen the rapid course of its development, from an idea concerned only with producing a hitherto-fantastic amount of thrust to an operational vehicle capable of significant scientific research. And always within the developmental frame was the spirit of evolution and progress.

Within the frame, we have seen the necessity for the vehicles--for testing again and again, analyzing the endless minutiae whose functionings must be understood and, if necessary, corrected, so that the later vehicles to be developed in the Saturn program will be absolutely safe for the priceless human cargo that they will loft into orbit.

For, while the Saturn I program is now completed, its influence is felt strongly throughout the United States space program. The lessons learned in the Saturn I program are of inestimable value for the design of future space rockets. And the design philosophy so carefully developed throughout the ten Saturn I vehicles will perhaps preserve the lives of our astronauts as they embark on ever greater ventures.

Mighty as the Saturn I was, it was but the first step on the stairway that leads ultimately to the stars. Gigantic and massive as it loomed, already it is being dwarfed by other, more ambitious rockets. And yet, as these successors to the Saturn I lift off, Saturn I will ride with them, in a way; for, from the knowledge gained from Saturn I, the later rockets grow. And as these sons of Saturn I probe outward, and in turn are replaced by later generations, it can truly be said that the Saturn I, an early pioneer in space exploration, lives within them still.

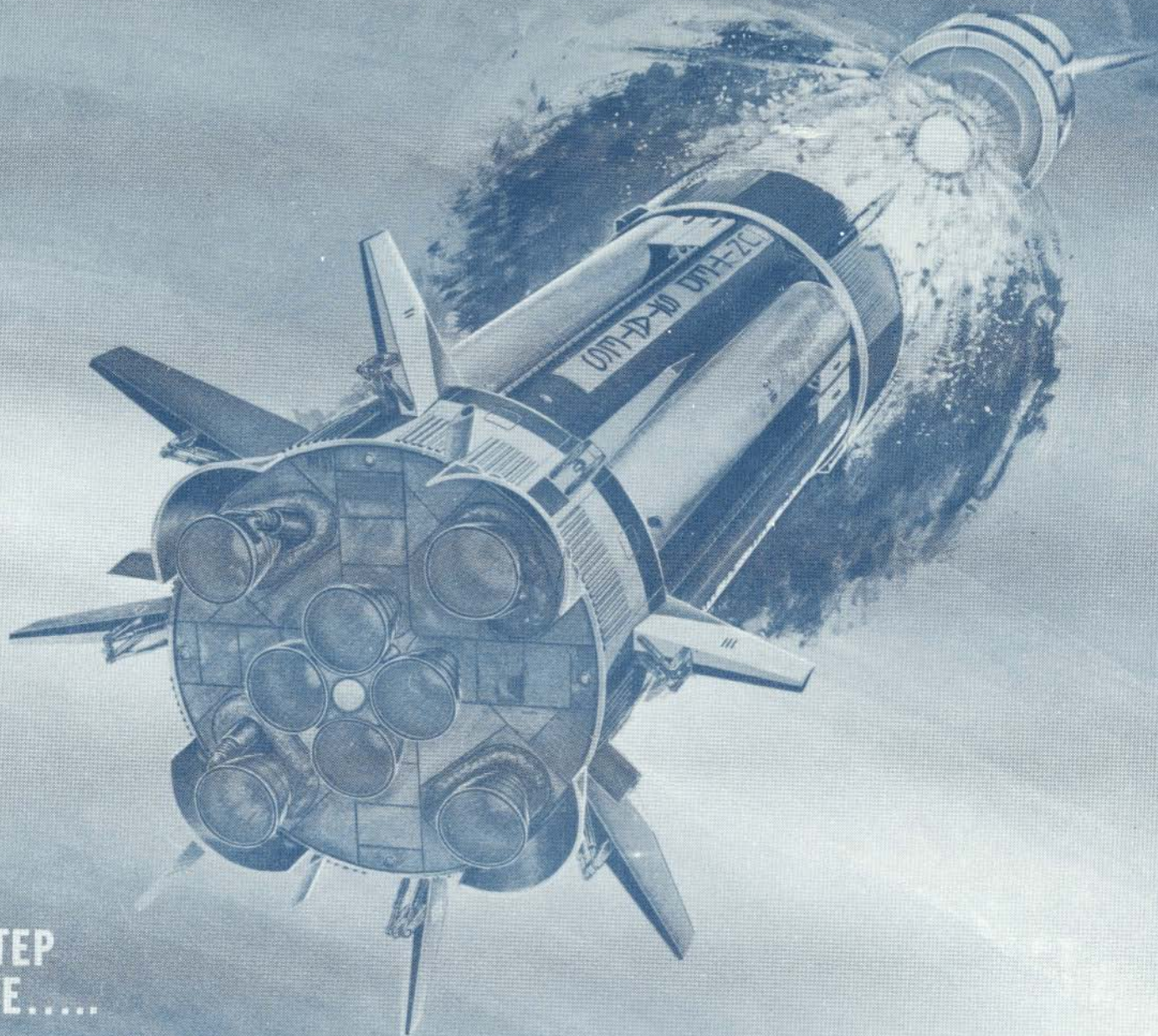

NEXT
SATURN STEP
INTO SPACE.....

